

Dual versions of CMOS circuits

Simple differential amplifier with mirror load

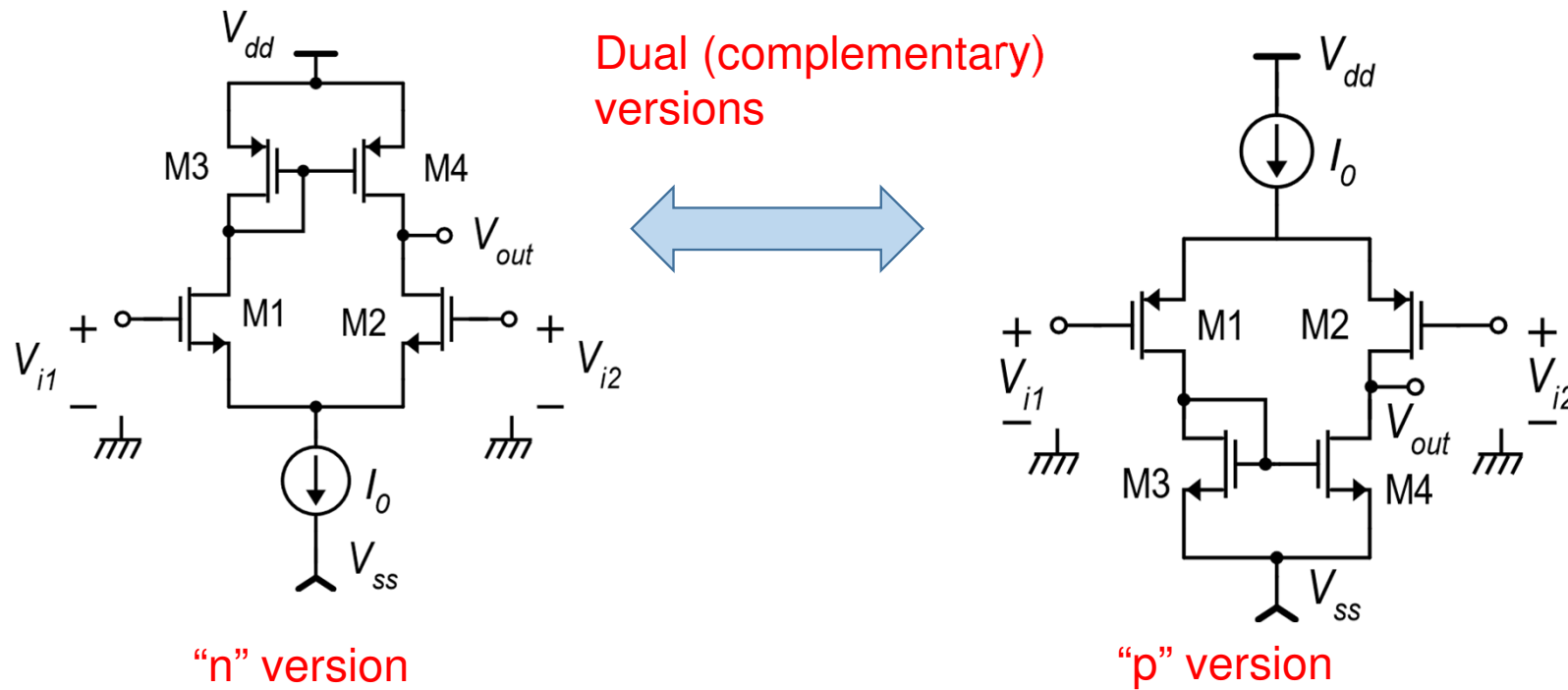

Ranges of the «p» version

- ➔ $\min(V_{out}) = V_C - V_{GS2} + V_{DSAT2}$
- ➔ $\max(V_{out}) = V_{dd} - |V_{DSAT4}|$
- ➔ $\min(V_{iC}) = V_{ss} + V_{MIN-tail} + V_{GS1}$
- ➔ $\max(V_{iC}) = V_{dd} - |V_{GS3}| - V_{DSAT1} + V_{GS1}$

- $\min(V_{out}) = V_{ss} + V_{DSAT4}$
- $\max(V_{out}) = V_C + |V_{GS2}| - |V_{DSAT2}|$
- $\min(V_C) = V_{ss} + V_{GS3} + |V_{DSAT1}| - |V_{GS1}|$
- $\max(V_C) = V_{dd} - V_{MIN-tail} - |V_{GS1}|$

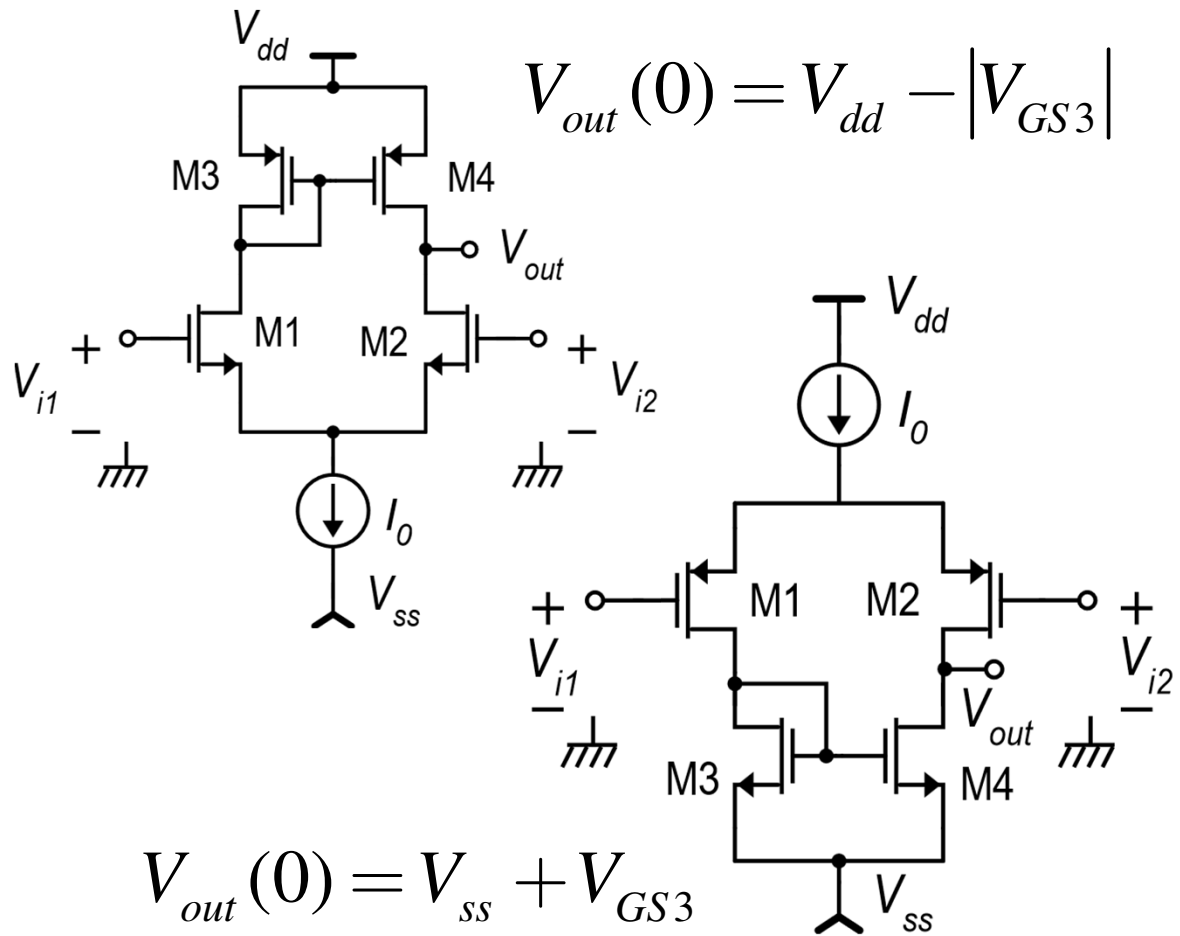

Ranges: graphical representation

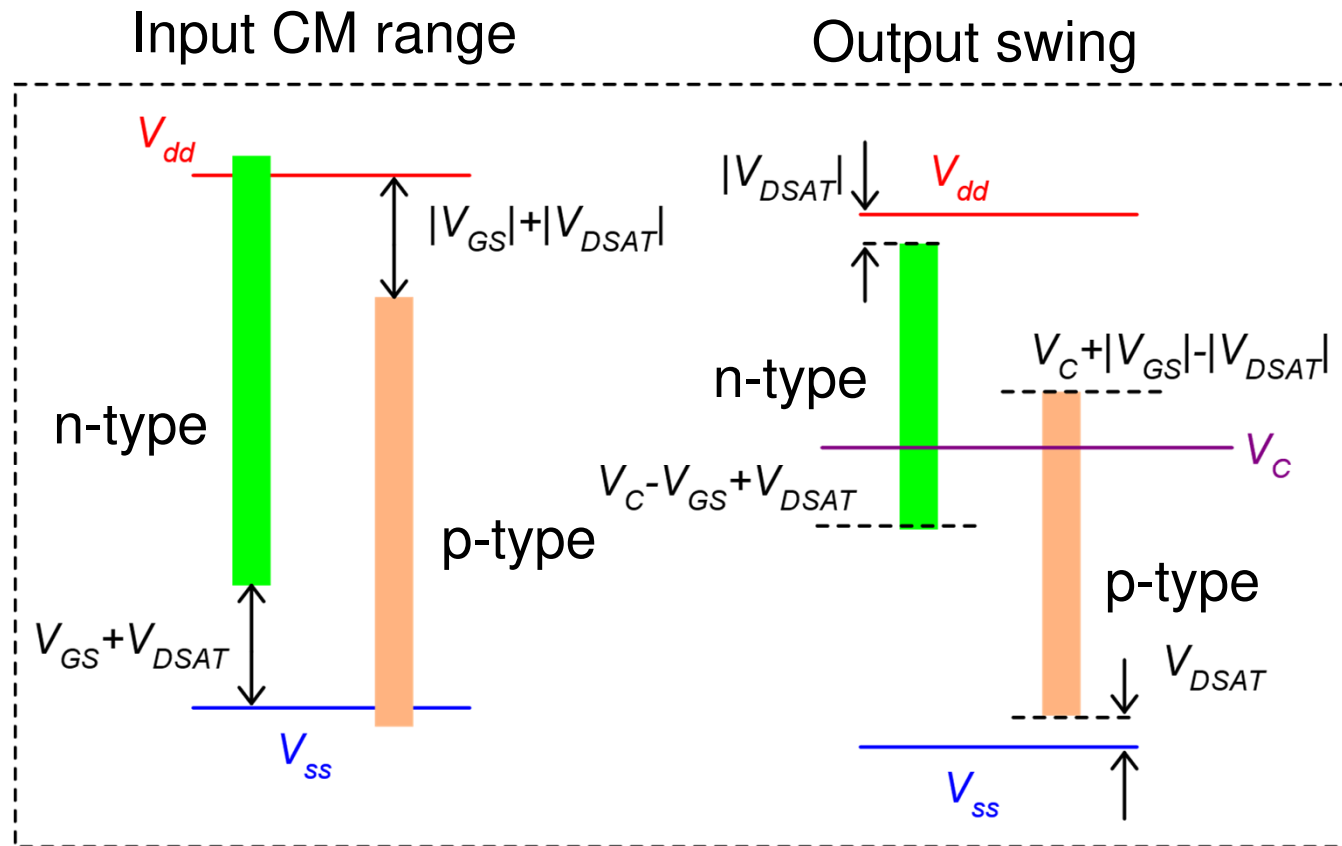

Improving the output swing: the OTA

OTA: Operational Transconductance Amplifier

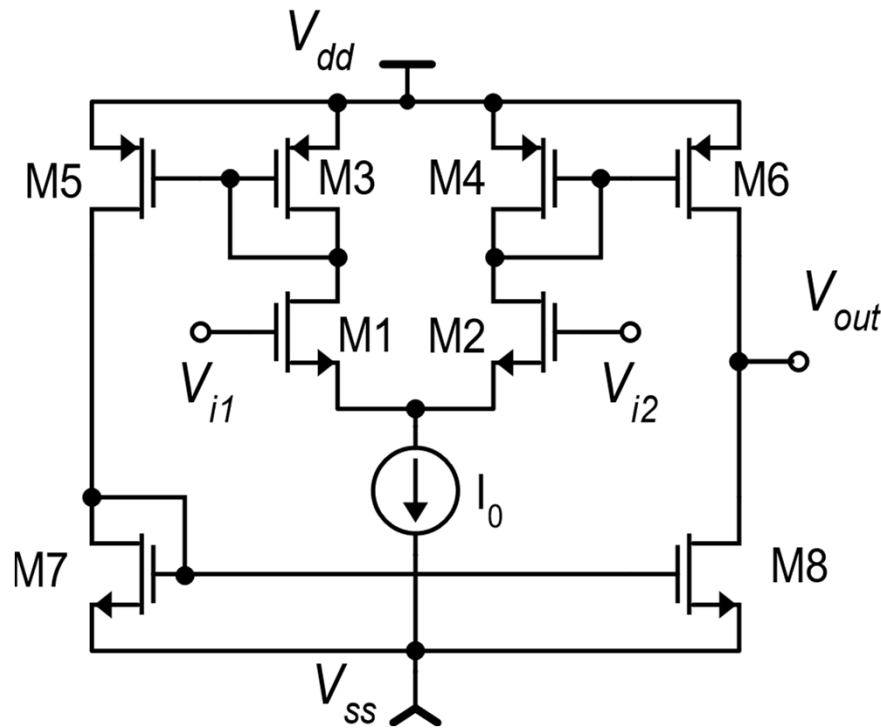

The term OTA generally indicates all single-stage amplifiers with high output resistance. The folded cascode amplifier is often classified as an OTA.

Historically, the term OTA has been used to indicate the topology shown in this slide

OTA: simple analysis

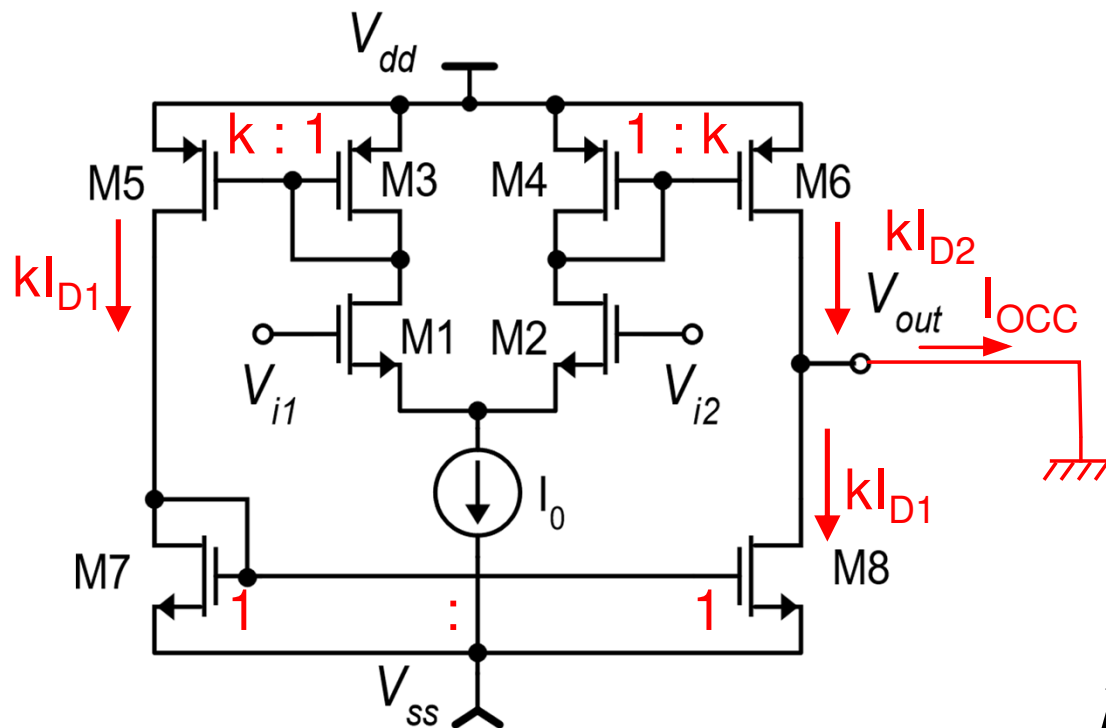

$$A_d = G_m R_{out}$$

$$I_{OCC} \cong k(I_{D2} - I_{D1}) \cong -k \cdot g_{m1} v_d$$

$$G_m = -k g_{m1}$$

$$R_{out} = r_{d6} // r_{d8} = \frac{1}{\lambda_6 I_{D6} + \lambda_8 I_{D8}}$$

$$I_{D6} = I_{D8} = k I_{D1}$$

$$A_d = -k \frac{I_{D1}}{V_{TE1}} \frac{1}{k I_{D1} (\lambda_6 + \lambda_8)} = \frac{1}{V_{TE1}} \frac{1}{(\lambda_6 + \lambda_8)}$$

Usage of the OTA as a transconductance amplifier

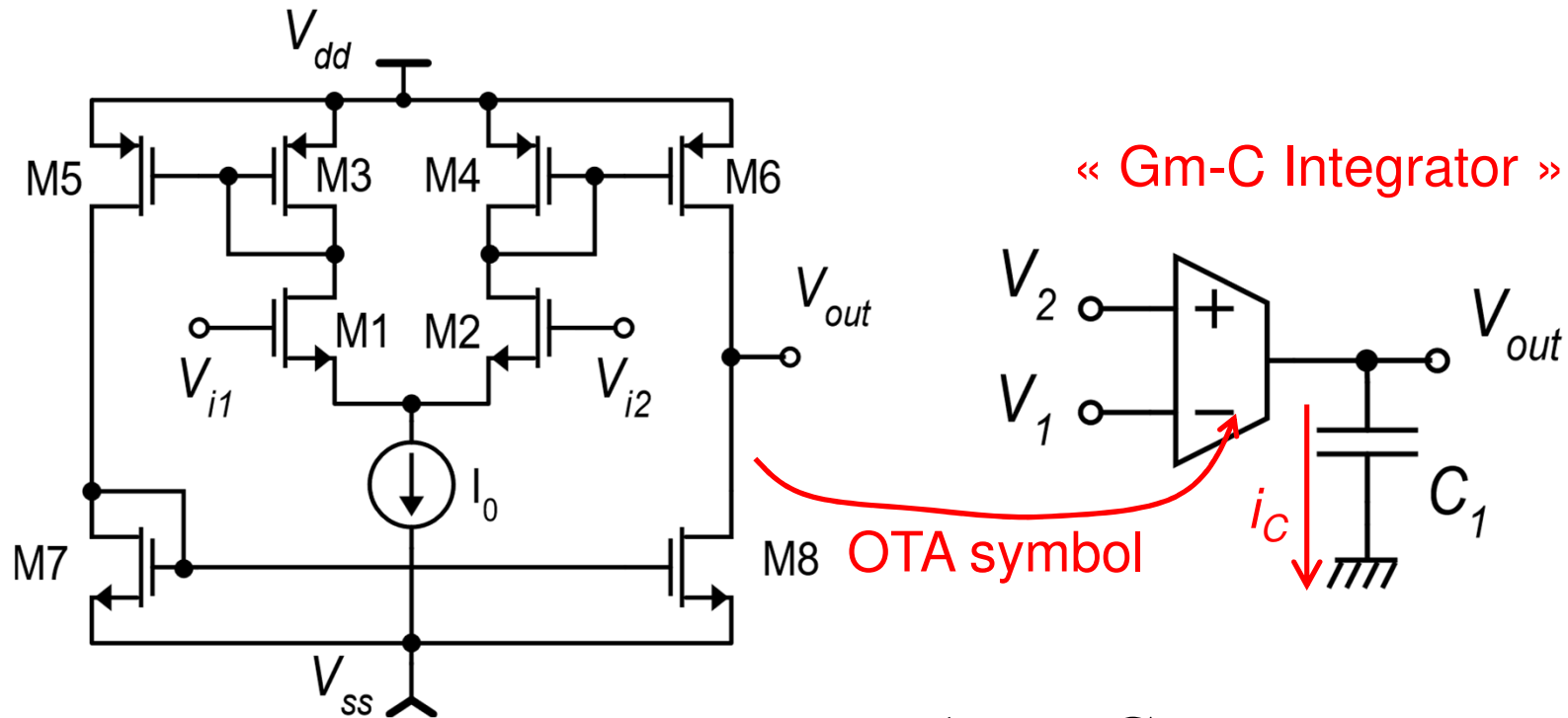

$$V_{out} = i_c \frac{1}{sC_1} = \frac{G_m}{sC_1} (V_2 - V_1)$$

OTA output swing

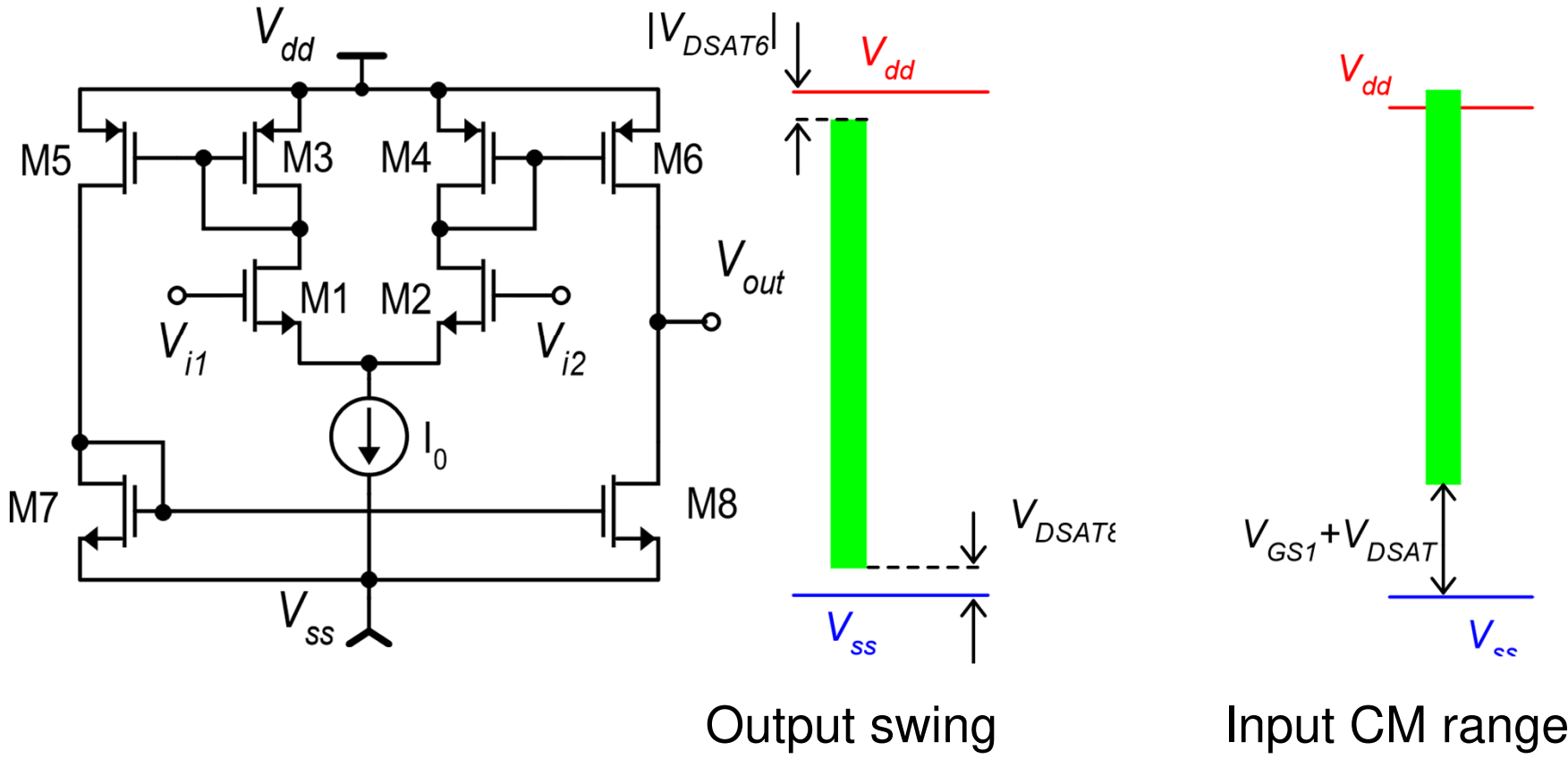

OTA with rail-to-rail input CM range

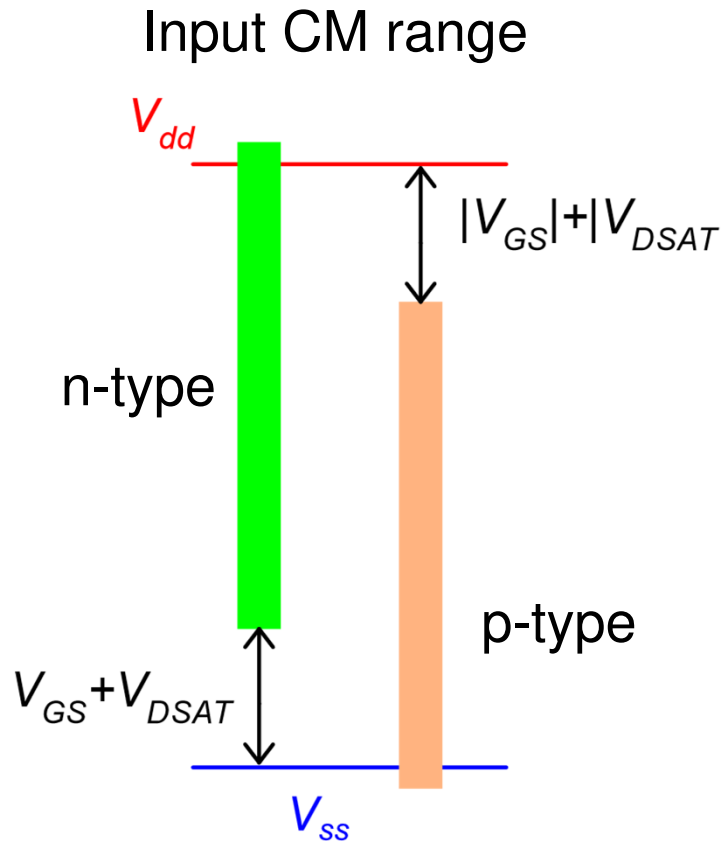

The idea is to make an n-type and p-type OTAs work together, In this way, for any value of the input common mode range, there is at least one OTA that operates correctly

OTA with rail-to-rail input CM range

$$I_{OCC} = (I_{D22} - I_{D21}) + (I_{D12} - I_{D11})$$

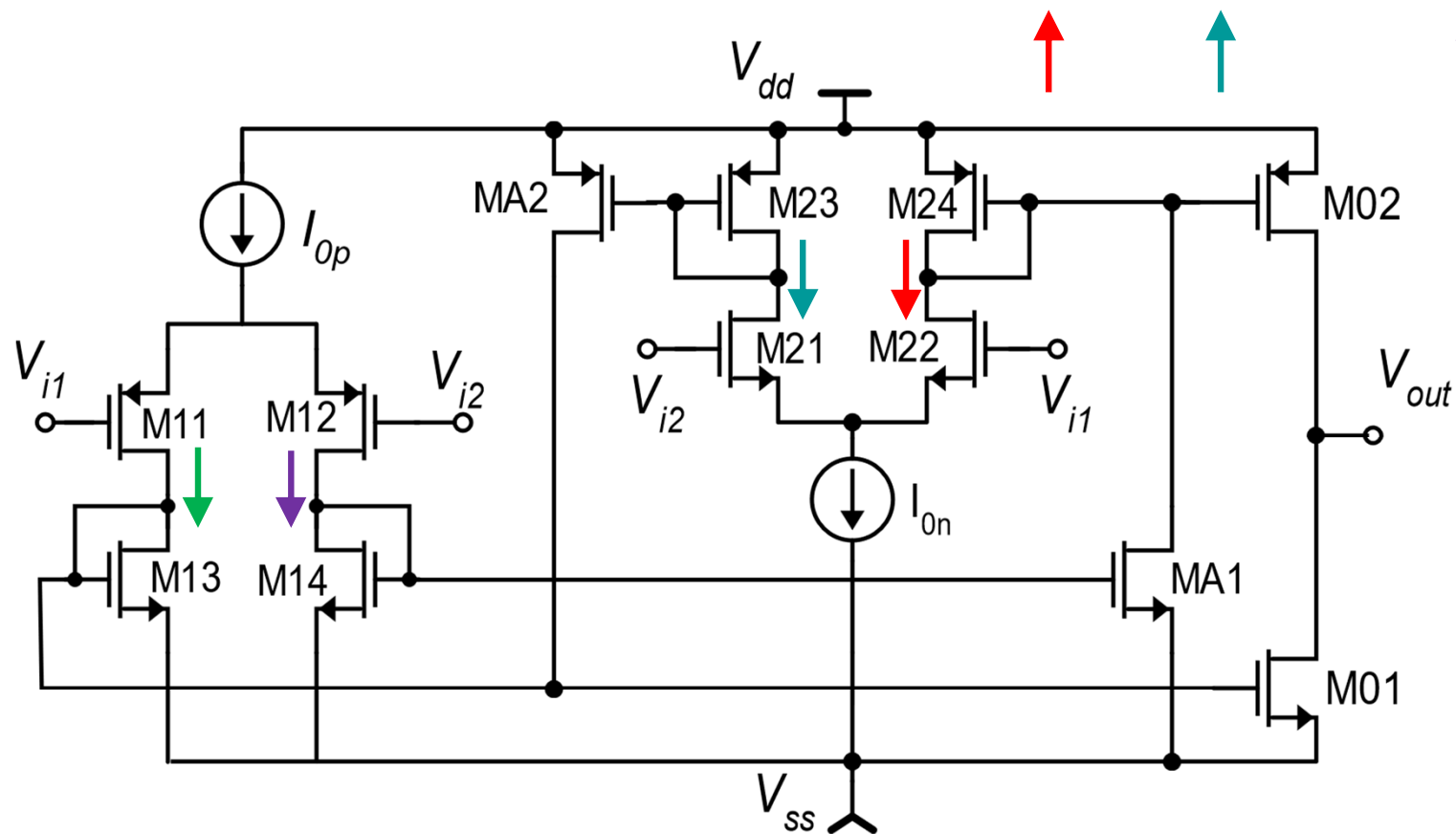

OTA rail-to-rail: equivalent Gm and dc gain

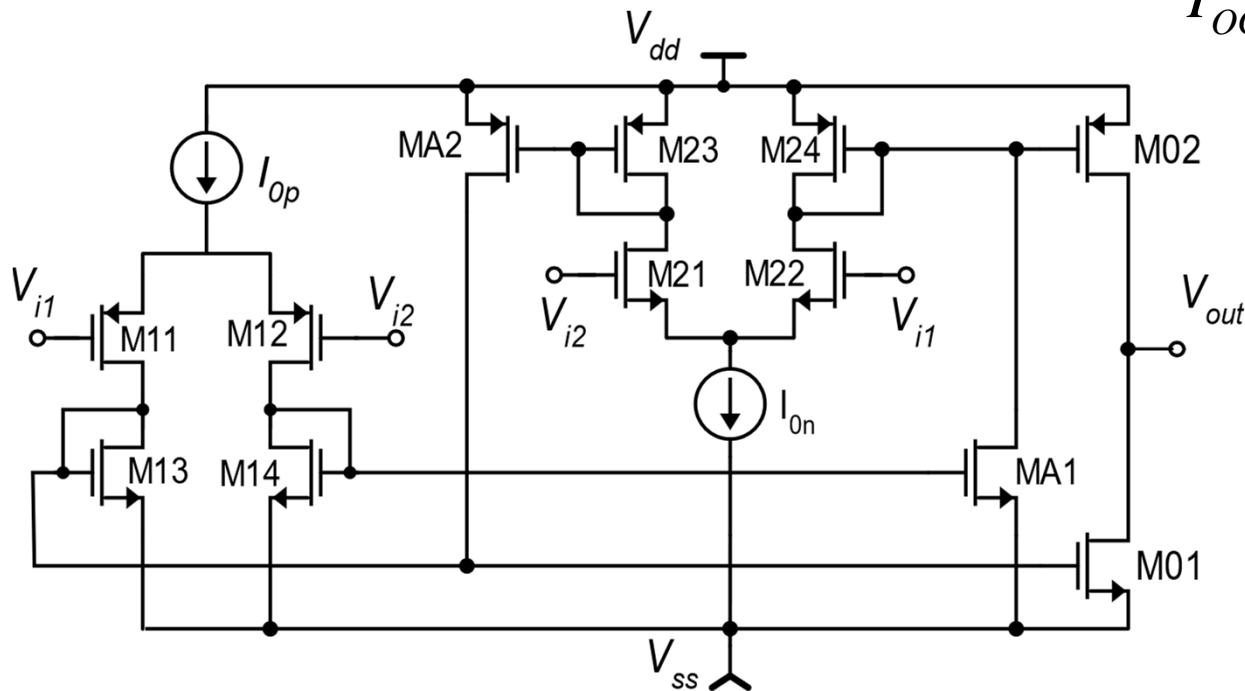

$$R_{out} = r_{d01} // r_{d02} = \frac{1}{\lambda_{01} I_{D01} + \lambda_{02} I_{D02}}$$

$$I_{OCC} = (I_{D22} - I_{D21}) + (I_{D12} - I_{D11})$$

$$I_{OCC} \cong G_m v_d$$

$$I_{OCC} \cong g_{mp} v_d + g_{mn} v_d$$

$$G_m = g_{m-n} + g_{m-p}$$

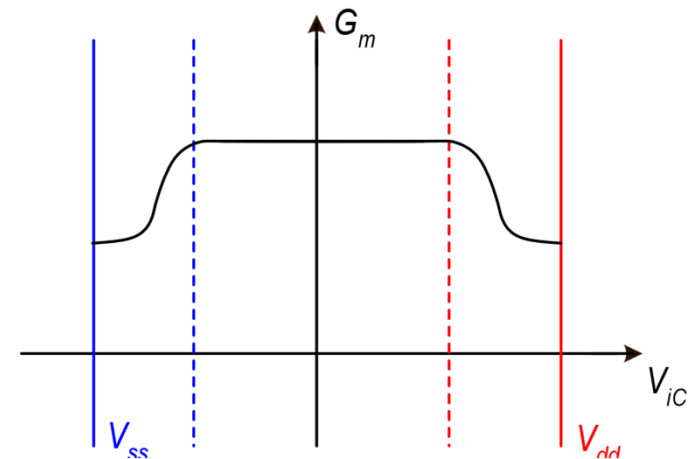

Example of CMOS Op-Amp RRIO using a folded cascode input stage and a complementary p-n input pair



OPA354, OPA2354, OPA4354

SBOS233G – MARCH 2002 – REVISED APRIL 2018

www.ti.com

8 Detailed Description

8.1 Overview

The OPAx354 is a CMOS, rail-to-rail I/O, high-speed, voltage-feedback operational amplifier designed for video, high-speed, and other applications. It is available as a single, dual, or quad op amp.

The amplifier features a 100-MHz gain bandwidth, and 150-V/ μ s slew rate, but the amplifier is unity-gain stable and can operate as a 1-V/V voltage follower.

8.2 Functional Block Diagram

