

Passive components in Integrated Circuits

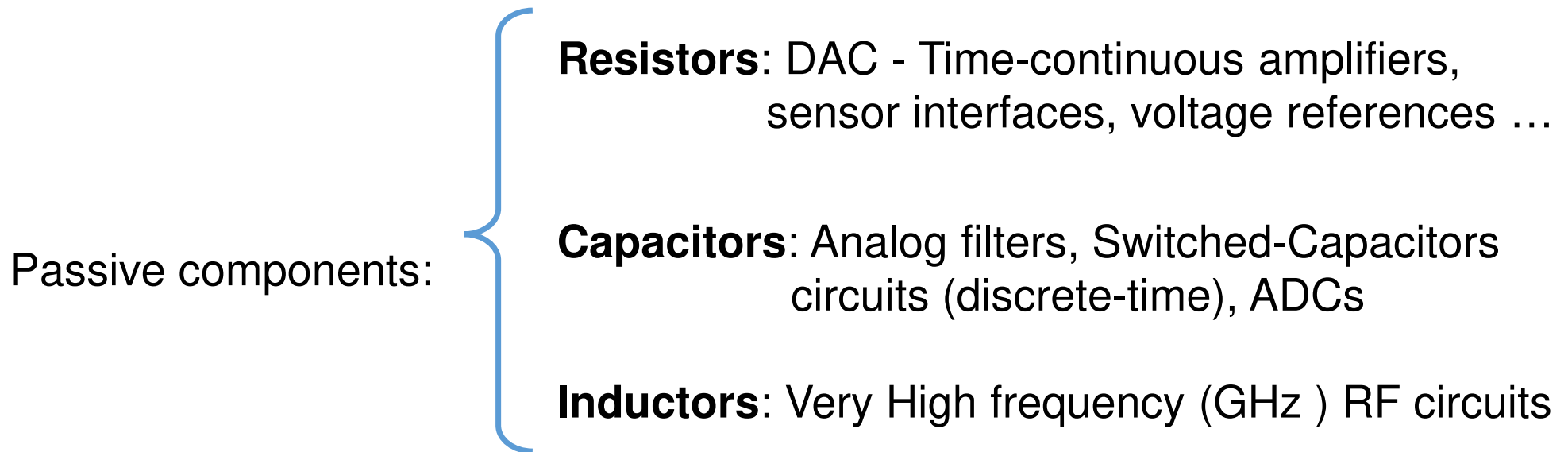

Precise resistors and capacitors are necessary for high accuracy analog applications.

Integrated resistors: general layout

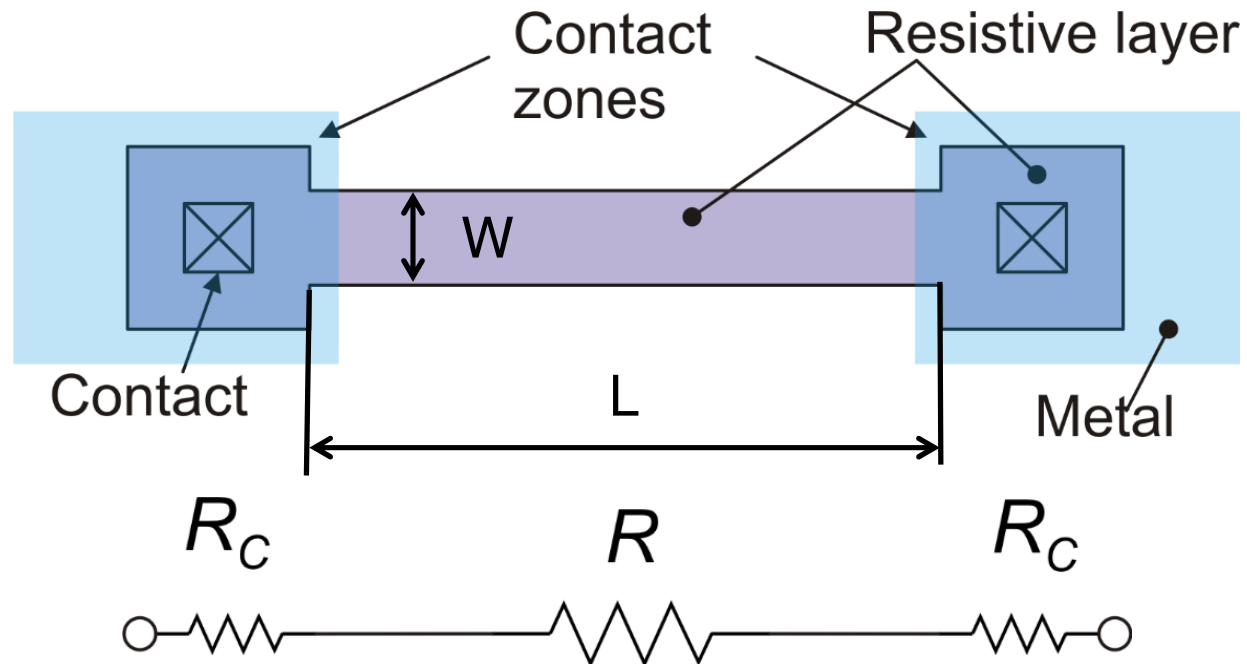

$$R = R_s \frac{L}{W} \quad \text{with} \quad R_s = \frac{\rho}{t} \quad R_{tot} = R + 2R_C$$

Resistor layout for $W \gg W_{\min}$

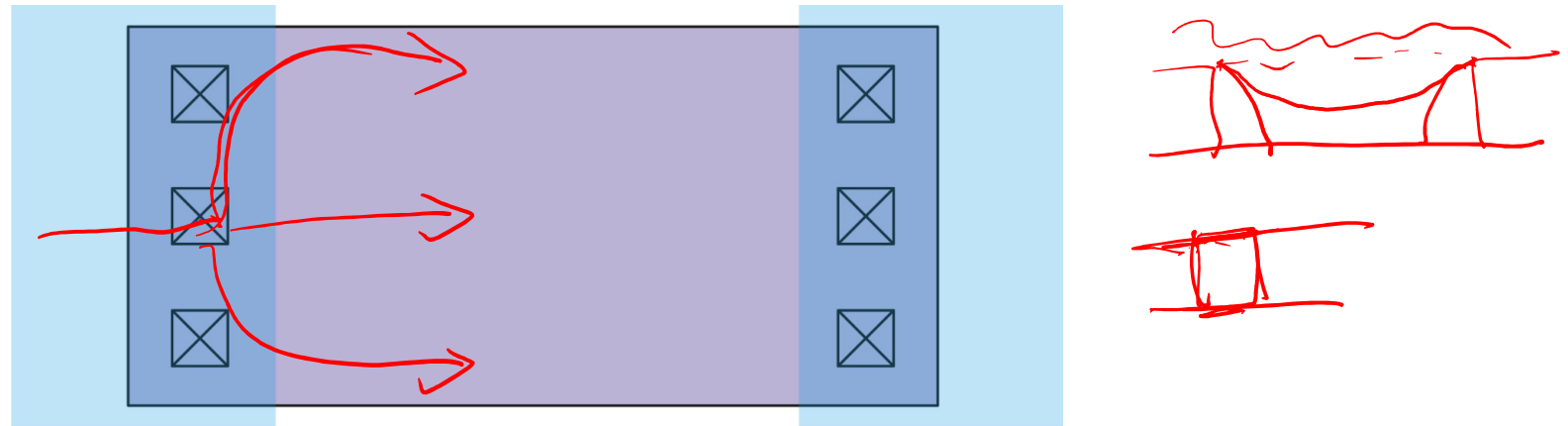

In some cases, we need to draw a resistor body with a width much larger than the minimum value dictated by the technology. This may occur when we need a resistor of low value that must carry relatively large currents. In this case, the resistor body width is already as large as to allow correct surround of contacts. If there is enough space, we add as many as possible contacts along the resistor width.

Resistors: quality parameters

- Sheet resistance (R_S): Large R_S means that large resistance values can be obtained using less area
- Voltage dependence: In integrated resistors, the resistance often depends on the voltage applied to the terminals

$$R = R_S \cdot \frac{L}{W}$$

$$L = \left(\frac{R}{R_S} \right) \cdot W_{min}$$

↑ 100 μ m



$$R(V) = R(0) [1 + \alpha_{V1} V + \alpha_{V2} V^2]$$

- Temperature dependence:



$$R(T) = R(T_0) [1 + \alpha_1 \cdot (T - T_0) + \alpha_2 \cdot (T - T_0)^2]$$

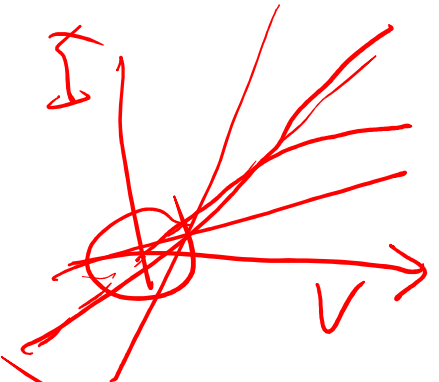

TCR: temperature coefficient of resistance: $\alpha_1 = TCR = \frac{1}{R} \frac{dR}{dT}$ $T = T_0$

Integrated resistors: Parasitic Components

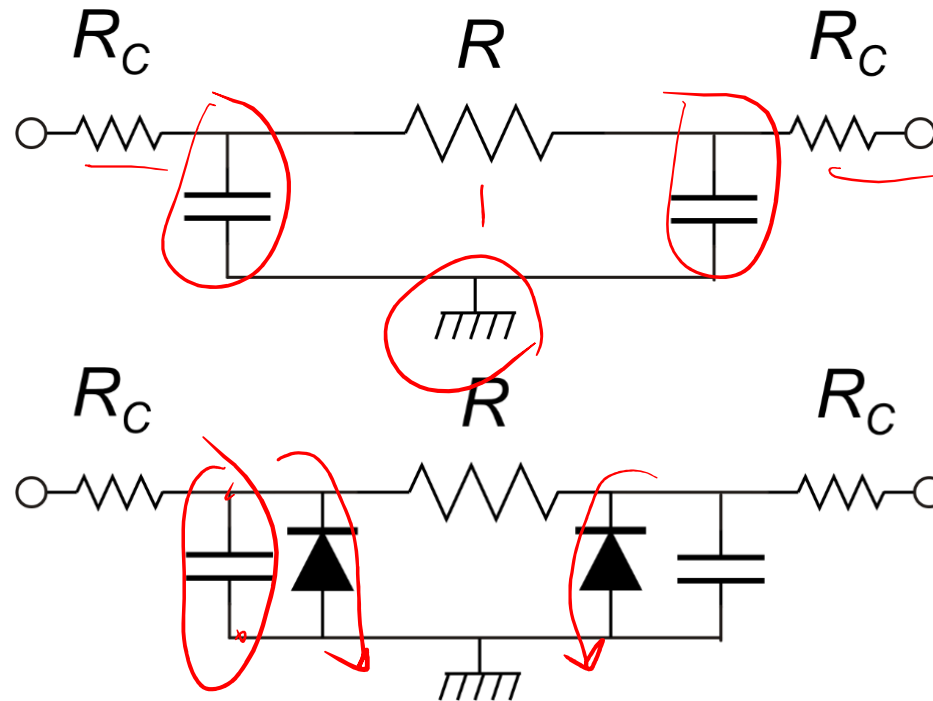

Unavoidable
parasitics

Needs Care!

Polysilicon resistors

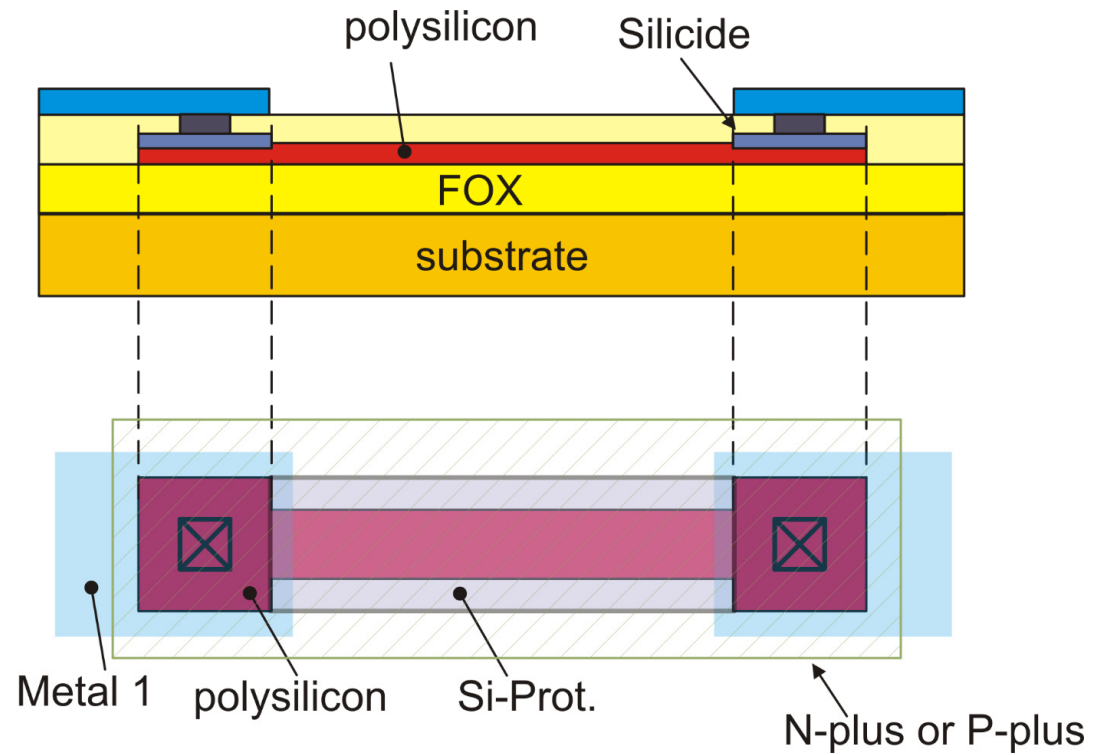

Typical characteristics of polysilicon resistors

Resistor Type	Sheet resistance	TCR	Non linearity (a_{V1})
n-plus polysilicon	30-150 Ω	100-500 ppm/ $^{\circ}$ C ←	50 ppm / V
p-plus polysilicon	50-400 Ω	250-1000 ppm/ $^{\circ}$ C ←	-50 ppm / V
high-res polysilicon	<u>400-4000 Ω</u>	-1000 ppm/ $^{\circ}$ C, -3000 ppm/ $^{\circ}$ C	100 ppm / V
Salicided polysilicon	5-10 Ω	2500-3500 ppm/C	-

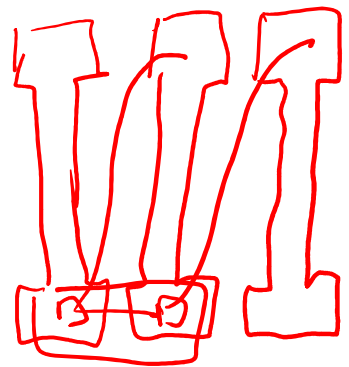
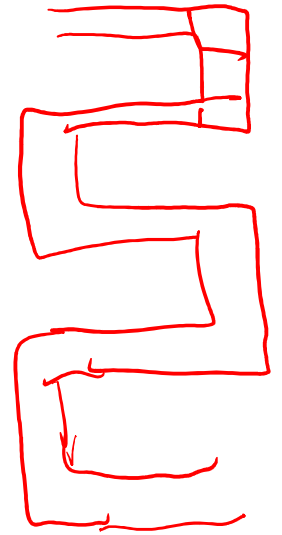

Diffusion Resistors

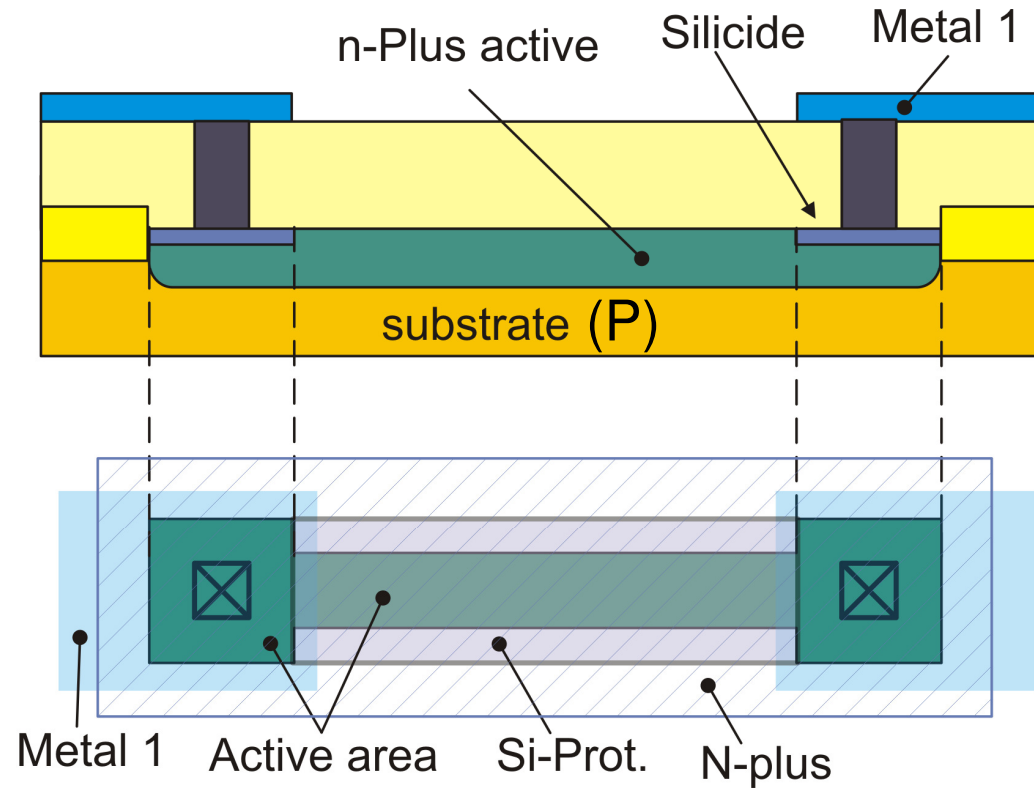

Voltage dependence in diffused resistors

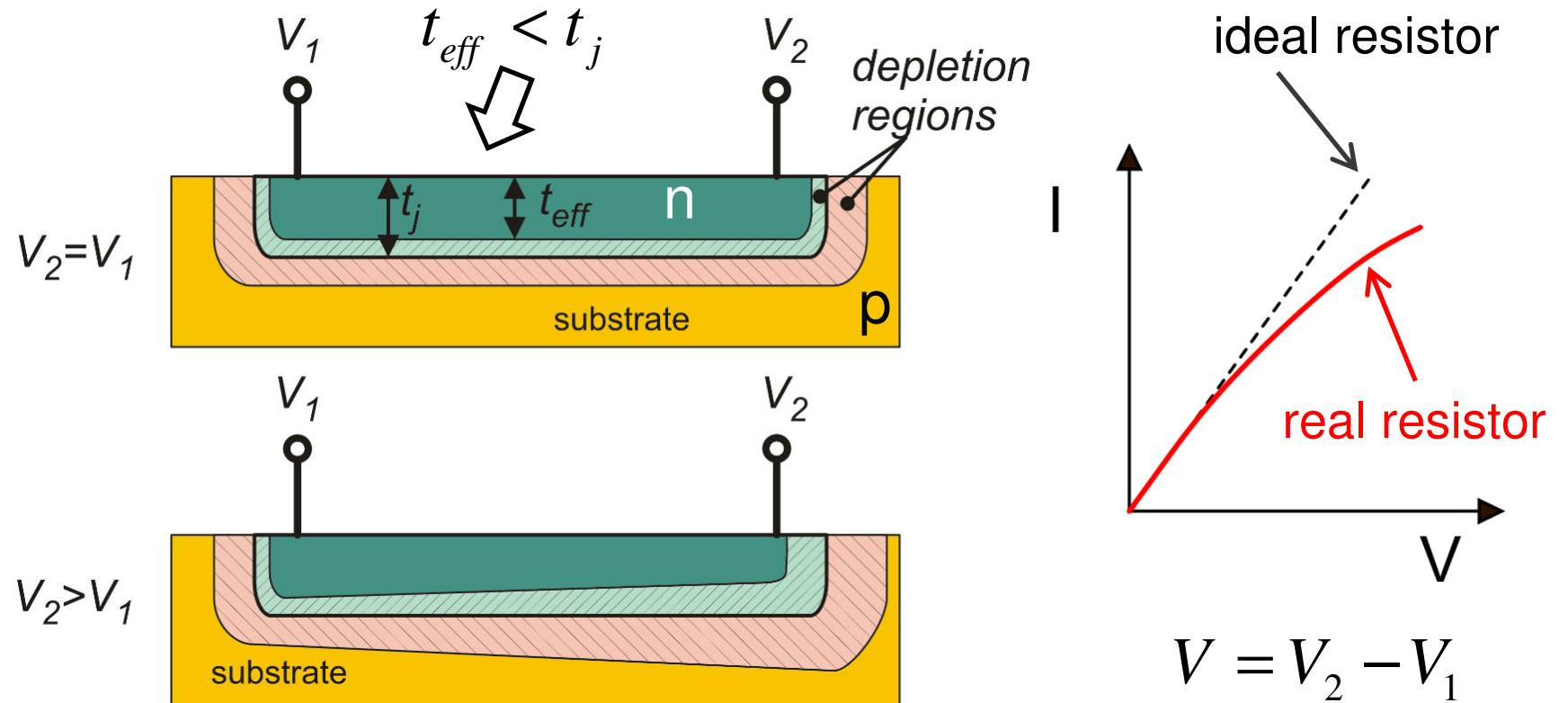

Other diffusion resistors

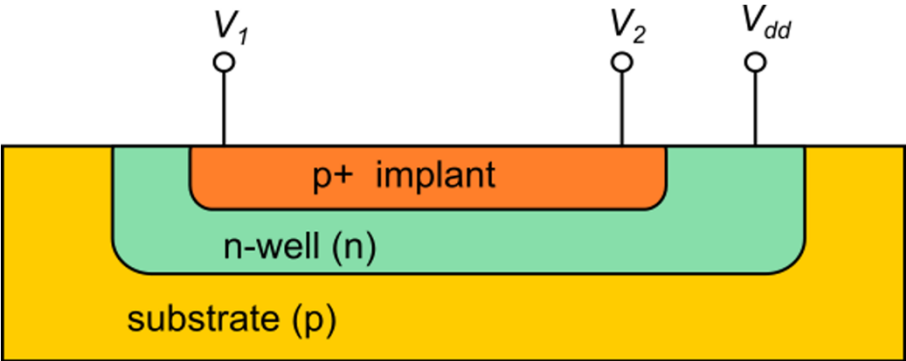

p+ resistor

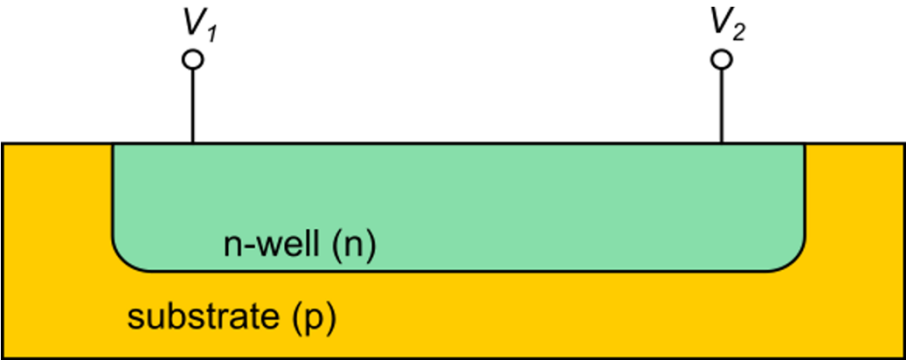

n-well resistor

Properties of diffused resistors

Resistor Type	Sheet resistance	TCR	Non linearity (a_{V1})
n-plus on substrate	30-80 Ω	1000-1500 ppm/ $^{\circ}$ C	400 ppm / V
p-plus on n-well	50-150 Ω	1000-1500 ppm/ $^{\circ}$ C	400 ppm / V
n-Well on substrate	400-4000 Ω	-2000, -3000 ppm/ $^{\circ}$ C	3000 ppm / V

Integrated capacitors: quality parameters

- **Capacitance per unit area:** critical when large capacitors have to be integrated into the chip. Typical values : $1 \text{ fF}/\mu\text{m}^2$ to $8 \text{ fF}/\mu\text{m}^2$.
- **Linearity:** A linear capacitance should be voltage independent. In some cases, the fact that a capacitance depends on voltage can be exploited to obtain tunable resonant circuits.
- **Temperature dependence.** Integrated capacitors exhibit a very low temperature dependence (a few tens of ppm/°C. Thus, this is seldom a critical point.
- **Parasitic components:** as for resistors, capacitors may be affected by parasitic components, typically capacitances to the substrate and parasitic diodes, when insulation is obtained by means of reverse-biased junctions.

Integrated Capacitors: MIM capacitors

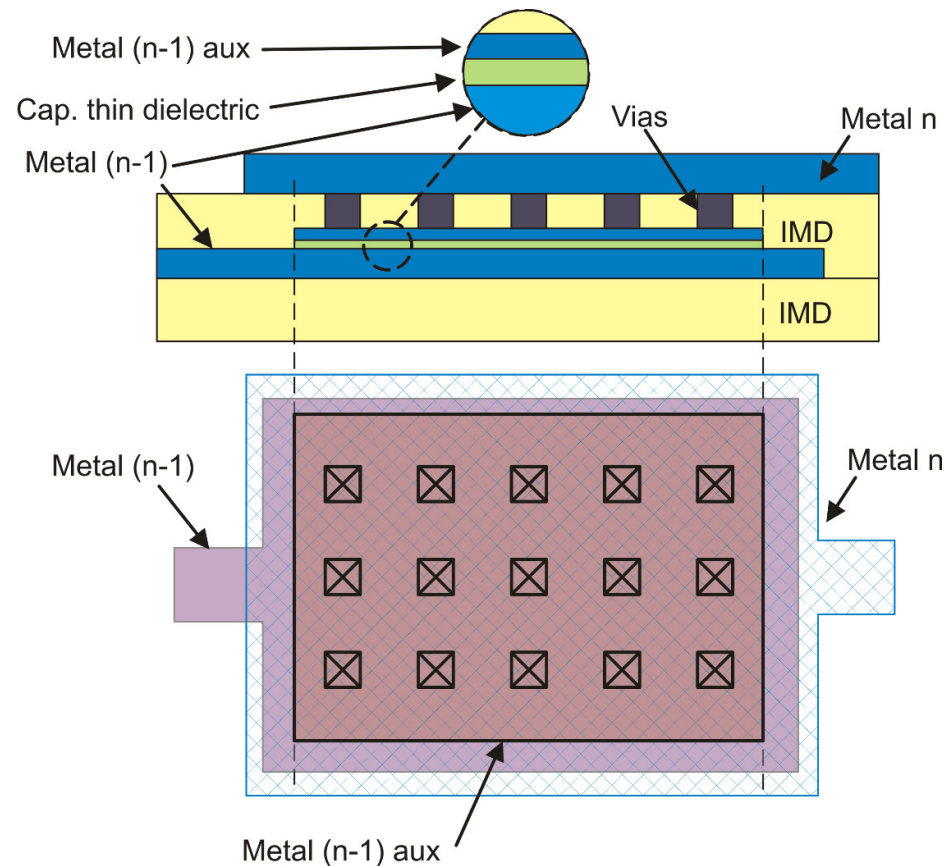

Typical capacitance density: $1 \text{ fF}/\mu\text{m}^2$

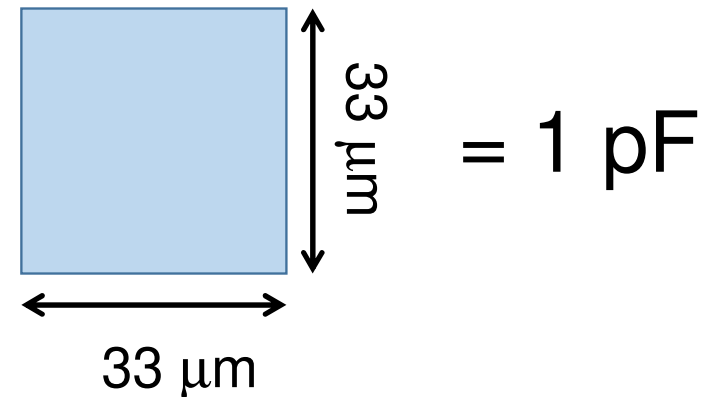

- Need additional process steps
- Relatively low density
- Possible leakage
- Withstand low voltages (a few V)

Integrated capacitors: MOM capacitors (flux capacitors)

Single layer MOM capacitor

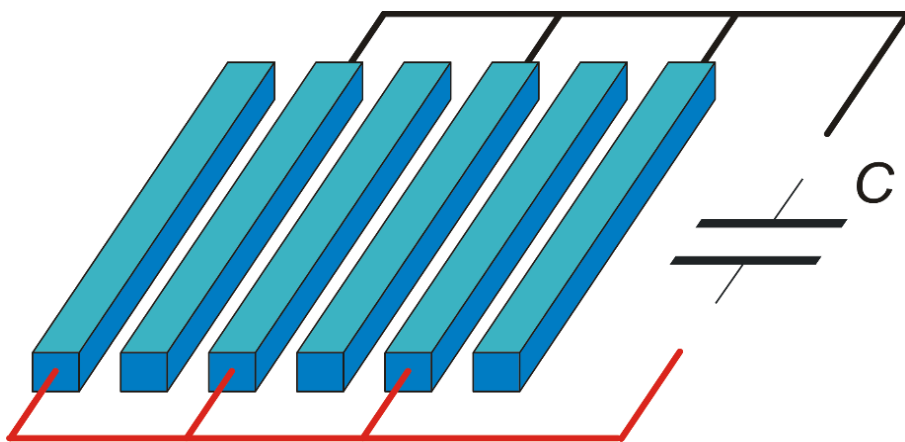

Standard metal interconnection layer

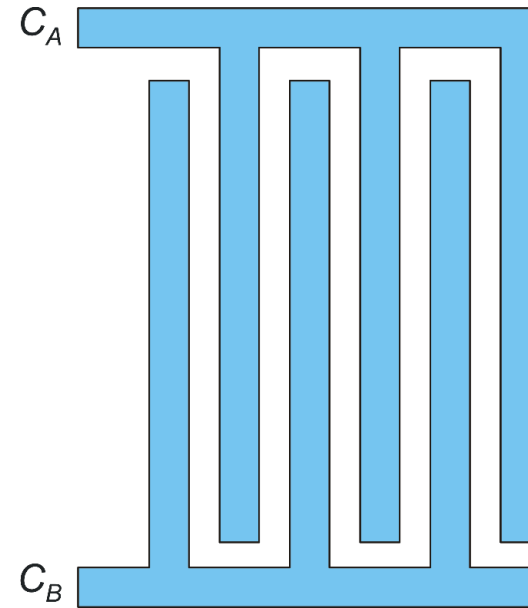

Layout of a 6-finger Single-layer MOM

Multi-layer MOM capacitors

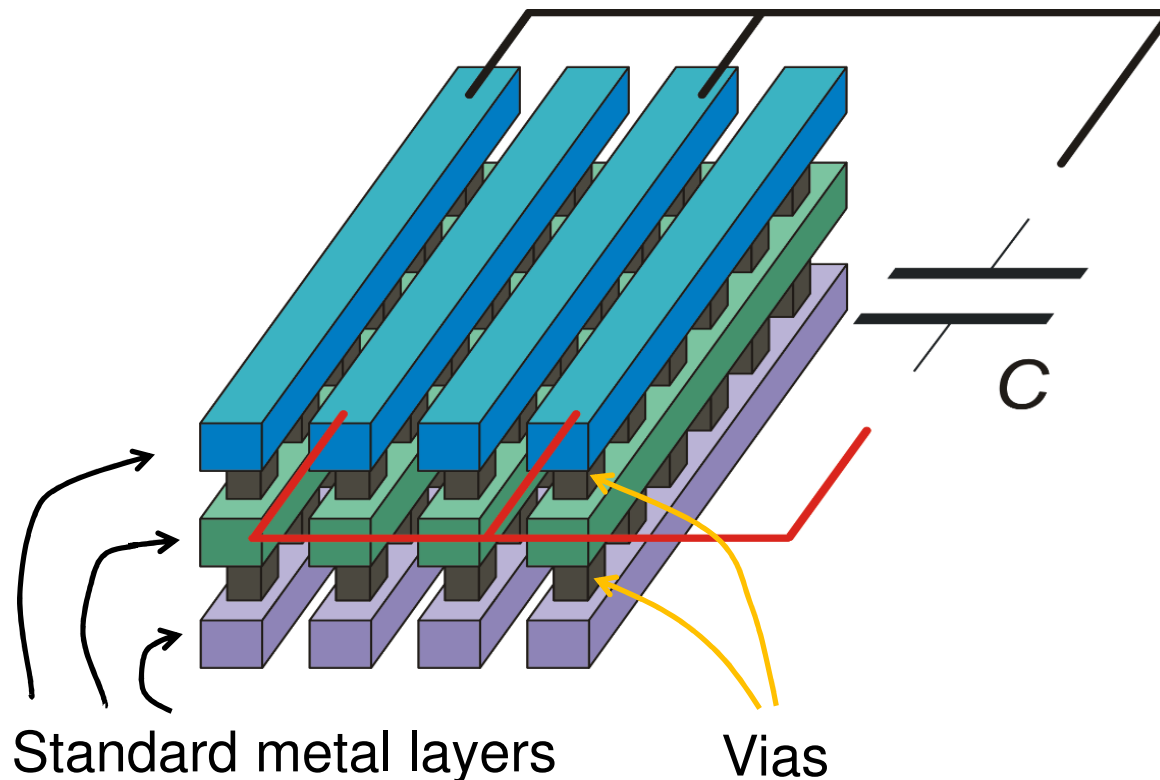

Multi-layer MOMs are required to obtain capacitance density comparable with MIMs

- + No additional process steps are required to fabricate MOMs
- + They withstand relatively high voltages (tens of V or more)
- Multi-layer MOMs are "walls" that cannot be crossed by other interconnection layers

Poly-Poly Capacitors

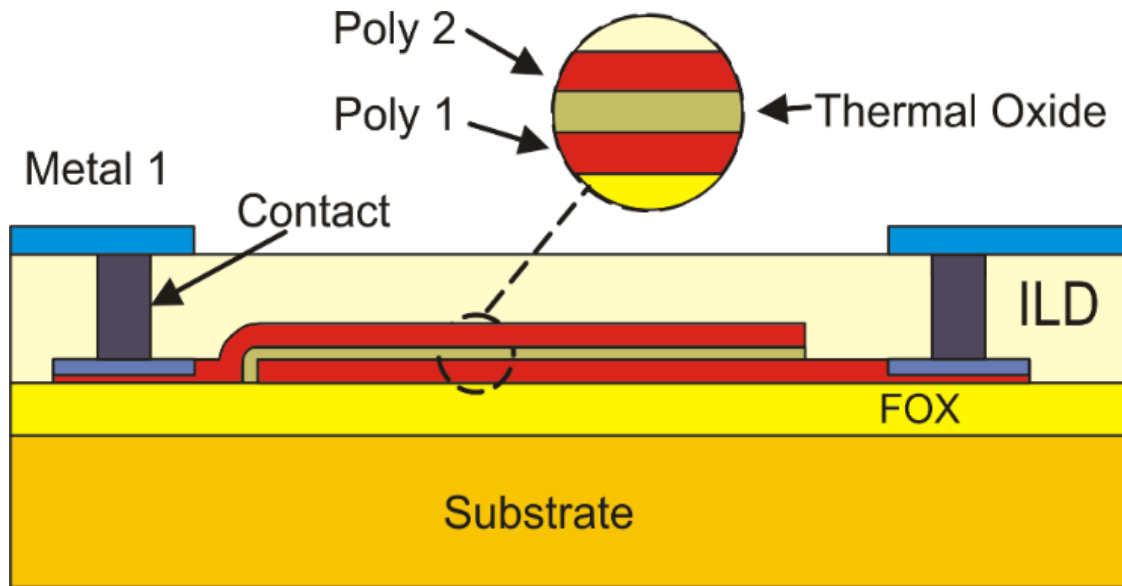

The non-linearity derives from the much greater (and non-linear) penetration of the electric field into the polysilicon plates with respect to metal ones.

Poly-poly capacitors can be integrated only **when two polysilicon layers** are available

- + Maximum capacitance density among integrated capacitors (up to $8 \text{ fF}/\mu\text{m}^2$)
- Higher non-linearity (voltage dependence) with respect to MIM and MOM cap.
- Only low voltages can be safely applied

Poly-implant capacitor

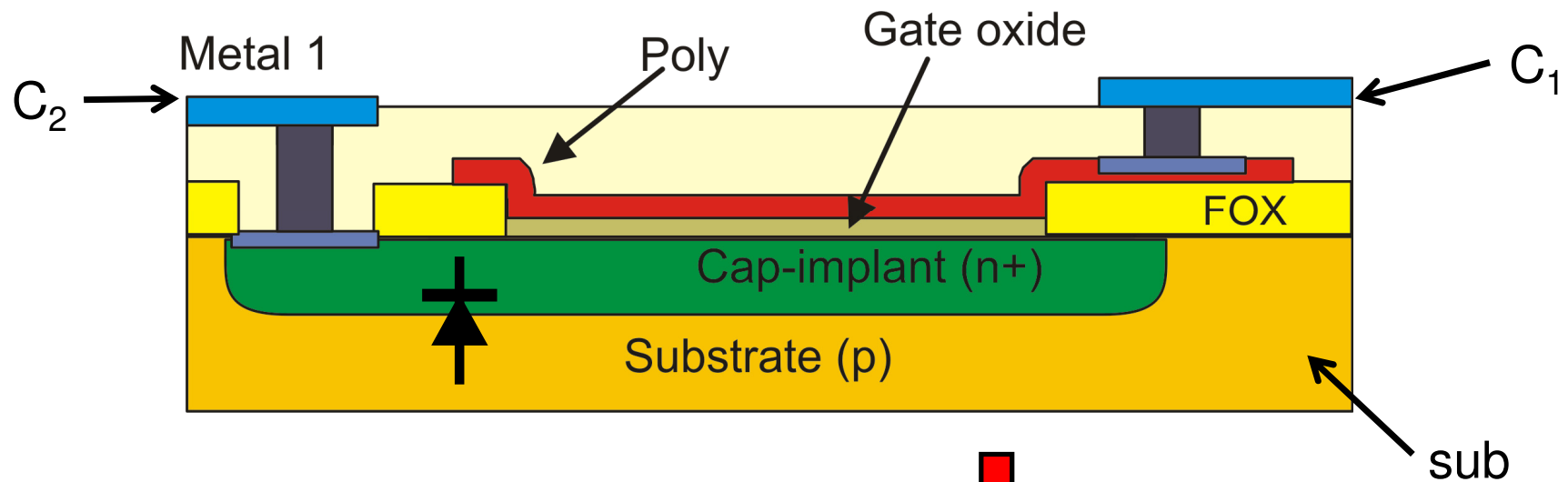

Some properties as poly-poly capacitors but presence of a parasitic junction between the lower terminal and the substrate.

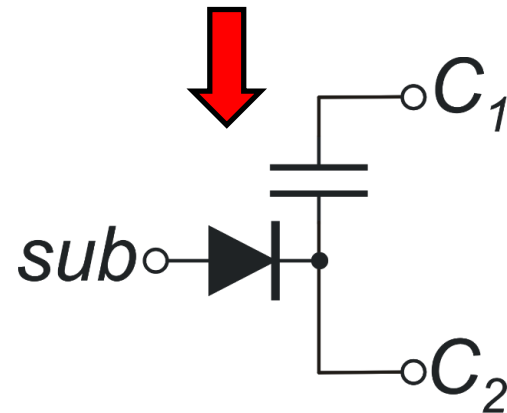

Junction Capacitors

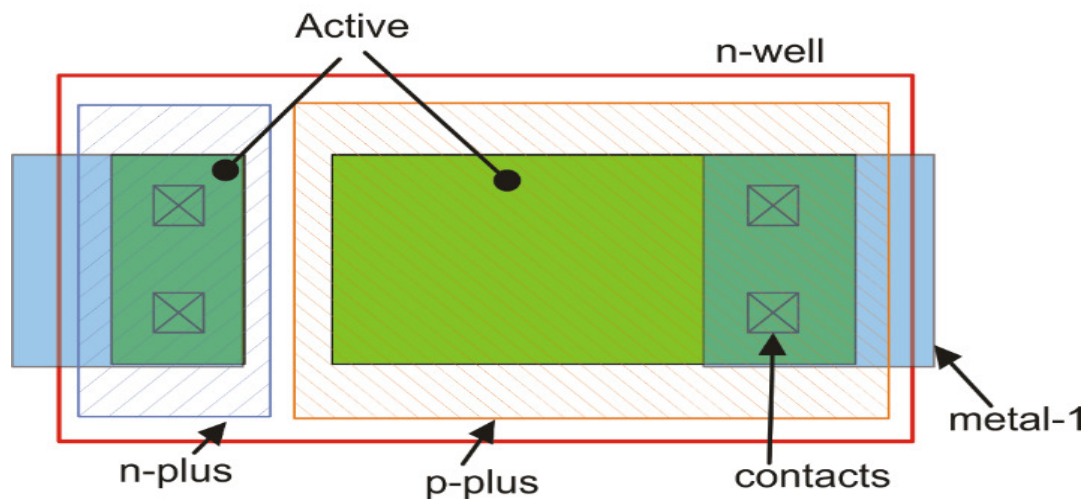
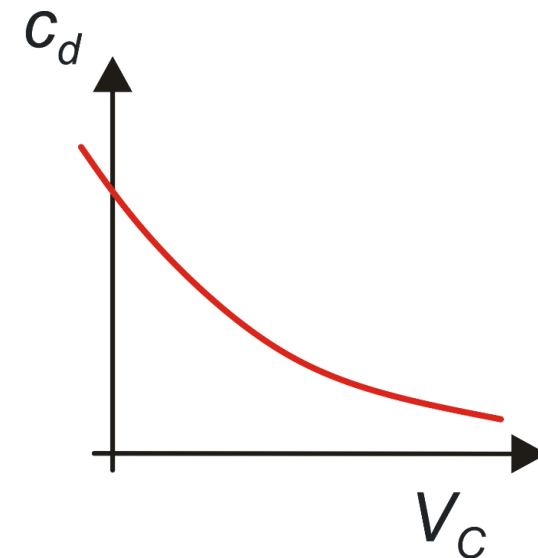
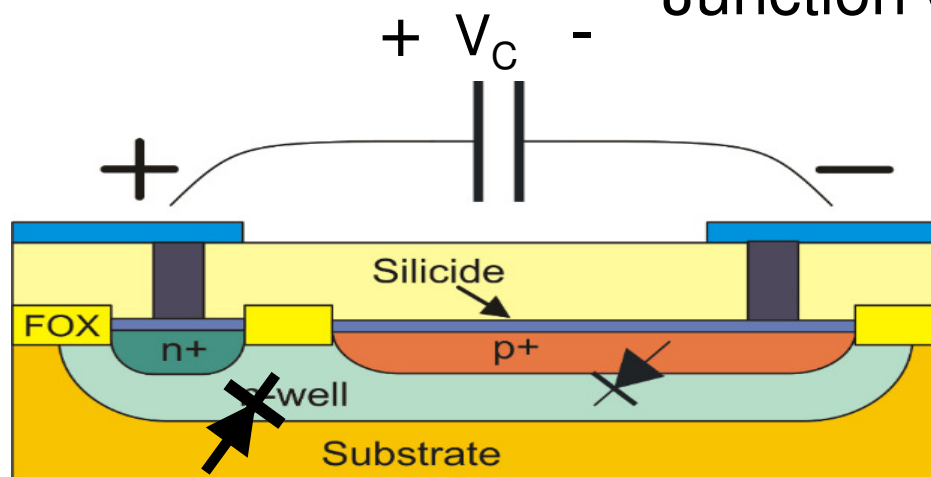

Due to the strong dependence on voltage, junction capacitances are used only for frequency compensation purposes or as bypass capacitors. The dependence on voltage can be used in RF applications to implement varactors for tuning of LC resonators: **(Varactors)**

Properties of Integrated Capacitors

Capacitor Type	Capacitance per unit area	Linearity (voltage dependence)	Parasitic components
MIM	1 fF / μm^2	< 100 ppm/ V	Capacitance to substrate (bottom plate only)
MOM (flux) 1 metal layer	0.1 fF / μm^2	< 100 ppm/ V	Capacitance to substrate (both terminals only)
MOM (flux) 6 metal layer	1 fF / μm^2	< 100 ppm/ V	Capacitance to substrate (both terminals only)
poly-poly	6 fF / μm^2	100 - 1000 ppm/V	Capacitance to substrate (bottom plate only)
poly-diffusion	6 fF / μm^2	100 - 1000 ppm/V	Diode to Substrate (bottom plate only)
junction	1 fF / μm^2	very –high (up to 30 % / V)	Diode to Substrate (bottom plate). Diode between terminals.