

The common gate stage

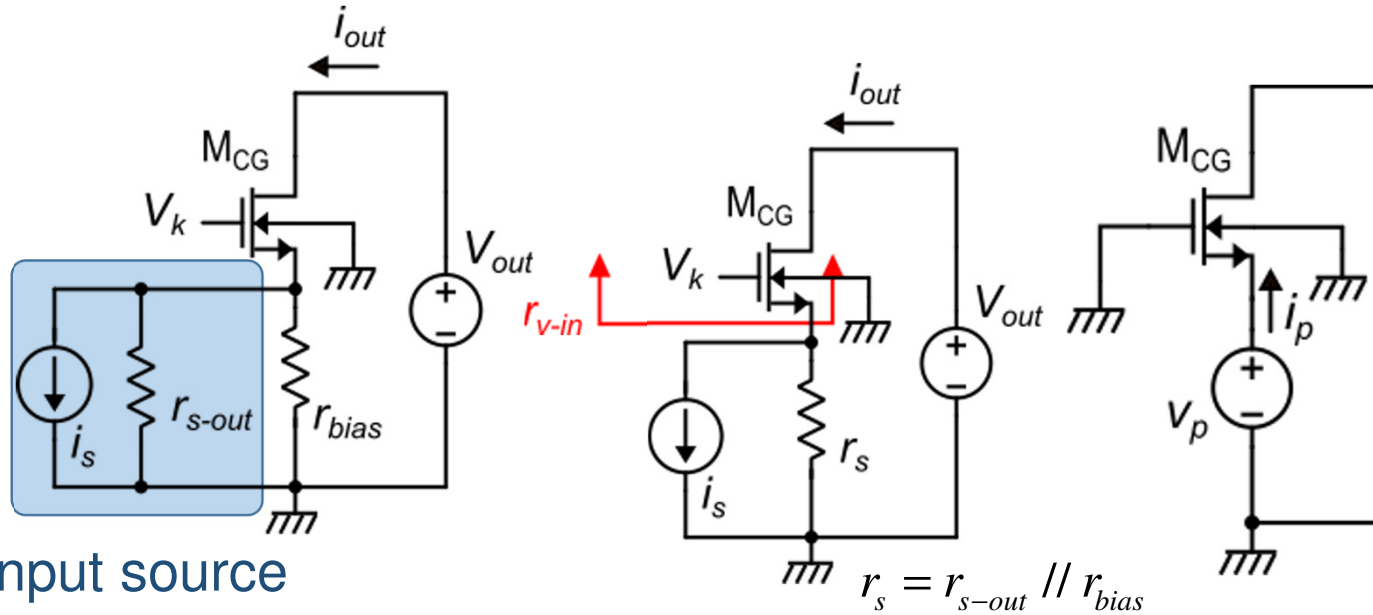

input source

A_I : current gain of the stage: $A_I = \frac{i_{out}}{i_s}$

$$A_I = \frac{i_{out}}{i_s} = \frac{r_s}{r_s + r_{v-in}} \cong \frac{r_s}{r_s + 1/mg_m} = \frac{mg_m r_s}{1 + mg_m r_s} \cong 1$$

$mg_m r_s \gg 1$

$$r_{v-in} = \frac{v_s}{v_s (g_m + g_{mb} + g_d)} \cong \frac{1}{(g_m + g_{mb})} = \frac{1}{mg_m} < \frac{1}{g_m}$$

$$g_{mB} = (m-1) \cdot g_m$$

$$r_{v-in} = \frac{v_p}{i_p} = \frac{v_s}{-i_d}$$

$$i_d = (g_m v_{gs} + g_{mb} v_{bs} + g_d v_{ds})$$

$$v_d = v_g = v_b = 0$$

$$v_{gs} = v_g - v_s = -v_s$$

$$v_{ds} = v_{bs} = -v_s$$

$$i_d = -v_s (g_m + g_{mb} + g_d)$$

The cascode configuration (cascode stage)

Operating point: $V_{DS1} = V_K - V_{GS2}$

V_{GS2} is mainly a function of:
 I_D, β_2

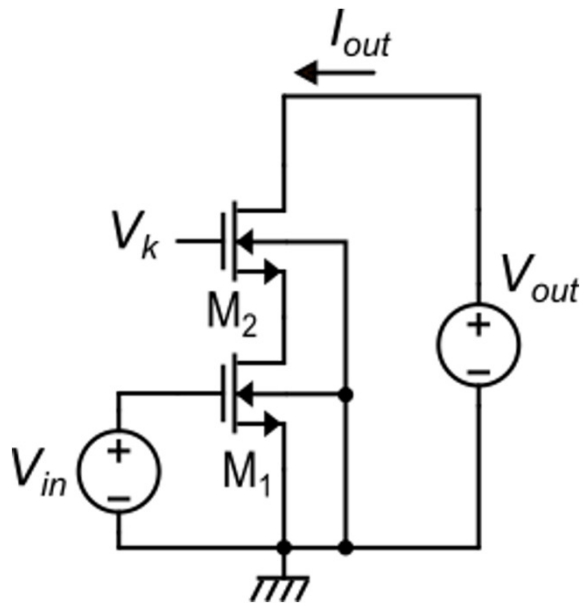

M1: Common source (CS)
M2: Common gate (CG)

Small signal, output short-circuit current

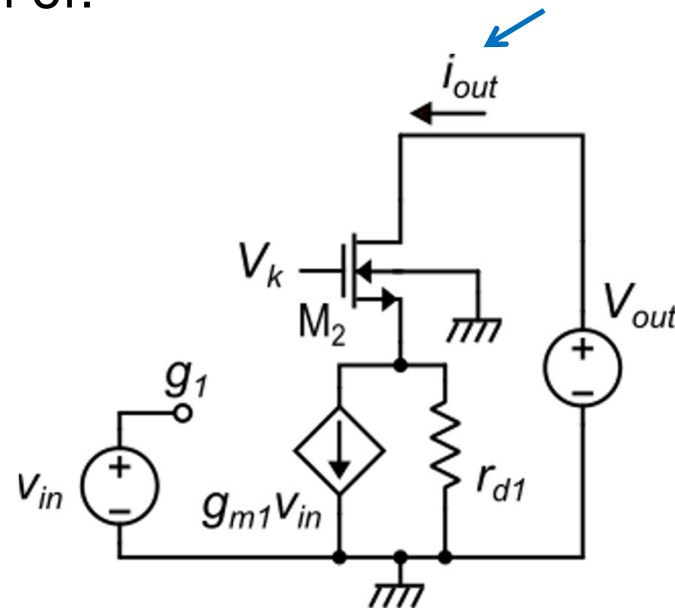

$$i_{out} = A_{I-CG} g_{m1} v_{in} \quad A_{I-CG} \cong 1$$

$$\frac{i_{out}}{v_{in}} = g_{m1} \frac{m_2 g_{m2} r_{d1}}{1 + m_2 g_{m2} r_{d1}}$$

$$\frac{i_{out}}{v_{in}} \cong g_{m1}$$

The common source (CS) and cascode (Ca) stages used as a voltage amplifiers

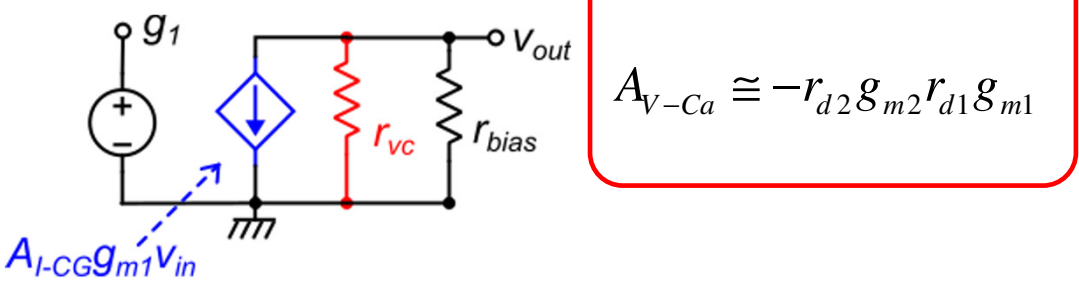
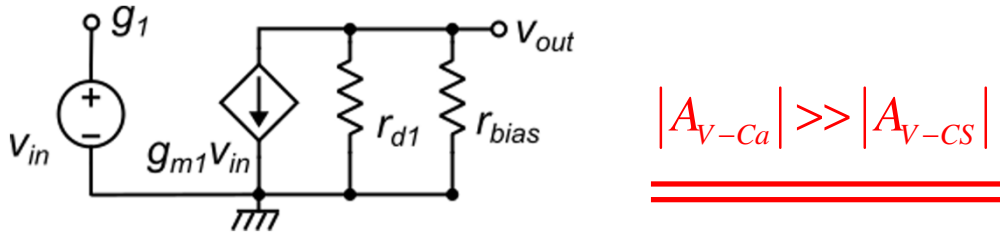
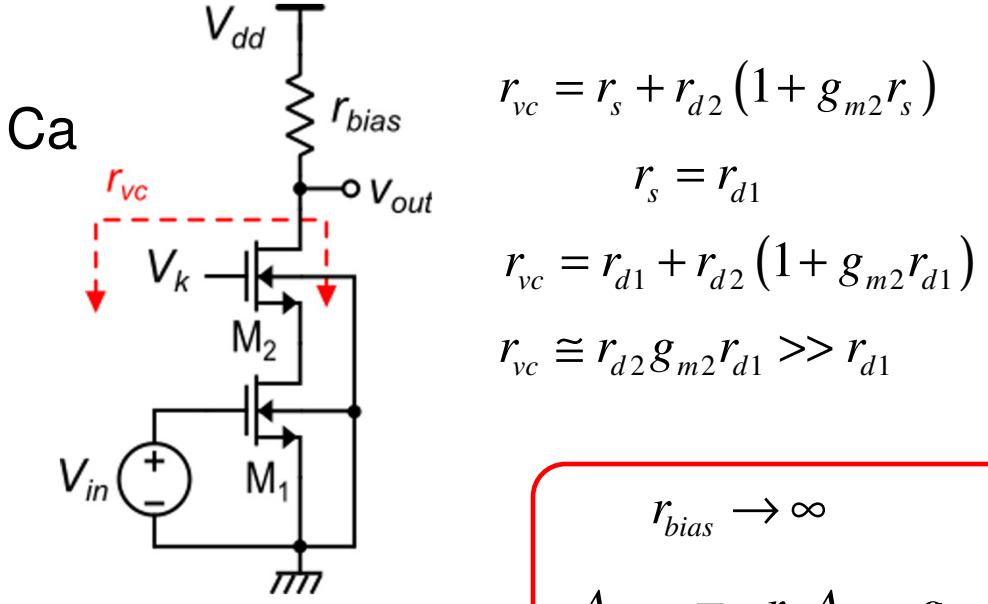
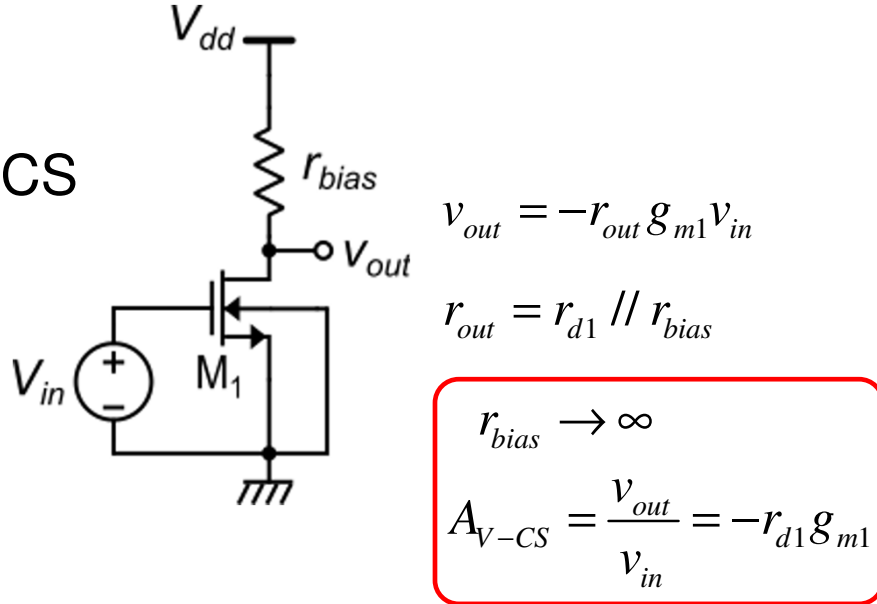

The common source (CS) and cascode (Ca) stages used as a voltage amplifiers

The cascode stage, thanks to its **much larger output resistance**, can reach **much larger voltage gains** than the common source stage, provided that the equivalent small signal resistance of the bias circuits can be neglected in the parallel.

The cascode is also convenient in terms of frequency response

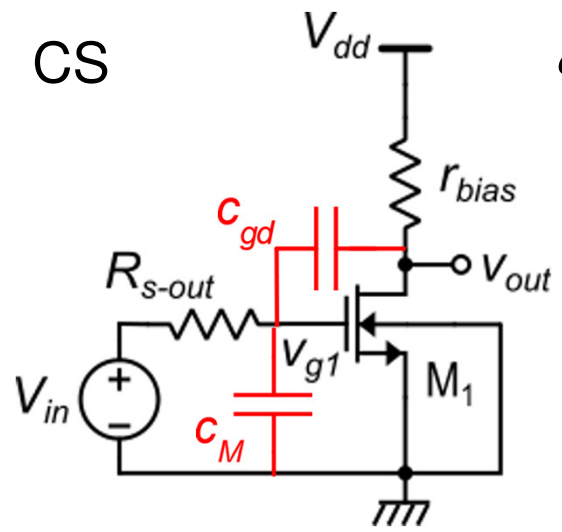

$$c_M = (1 + |A_V|) c_{gd}$$

$$c_M \gg c_{gd}$$

$$\omega_{p-in} = \frac{1}{(c_M + c_{GS}) R_{s-out}}$$

ω_{p-in} may affect the amplifier cut-off frequency

$$c_M = \left(1 + \left| \frac{v_{d1}}{v_{g1}} \right| \right) c_{gd}$$

$$v_{d1} \cong -g_{m1} v_{g1} \frac{1}{mg_{m2}}$$

$$\frac{v_{d1}}{v_{g1}} \cong \frac{g_{m1}}{mg_{m2}} \approx 1$$

$$c_M \approx 2c_{gd}$$

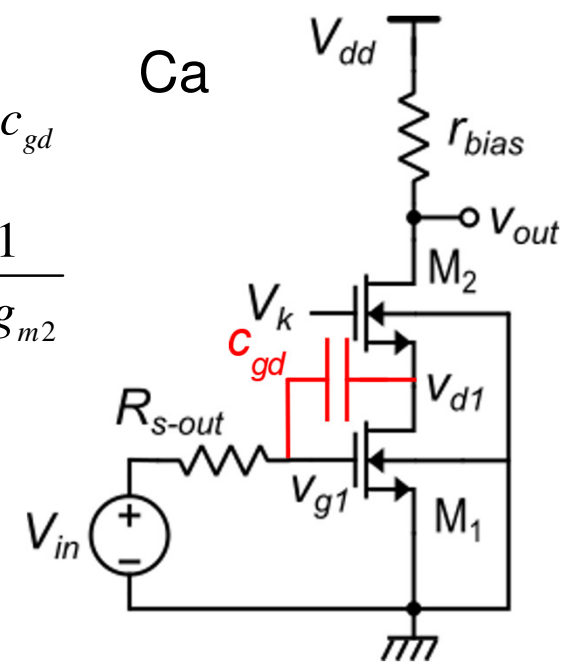

Cascode structure: effect of V_{out} variations on M1 and M2

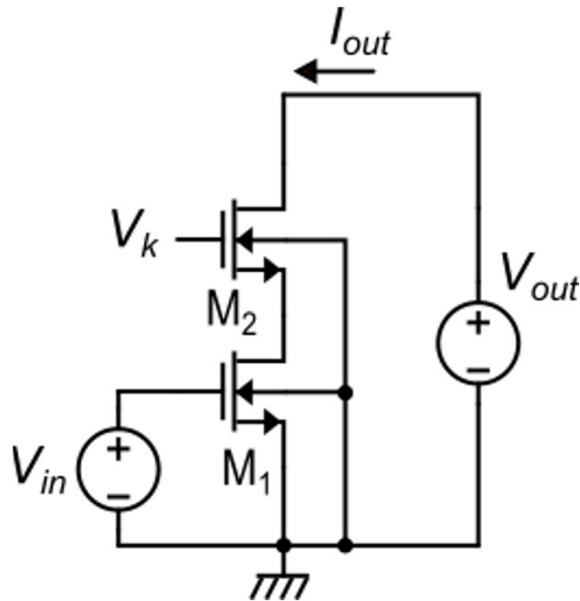

$$i_{d1} = \cancel{g_{m1}v_{gs1}} + \cancel{g_{mB1}v_{bs1}} + v_{ds1}g_{d1} = v_{s2}g_{d1}$$

$$i_{d2} = g_{m2}v_{gs2} + g_{mB2}v_{bs2} + g_{d2}v_{ds2} = -g_{m2}v_{s2} - g_{mB2}v_{s2} + g_{d2}(v_{out} - v_{s2})$$

$$v_{ds1} = v_{d1} = v_{s2}$$

$$v_{gs2} = v_{bs2} = -v_{s2}$$

$$v_{ds2} = v_{out} - v_{s2}$$

$$i_{d2} = i_{d1} = i_{out}$$

$$v_{out}g_{d2} = v_{s2}(g_{m2} + g_{mB2} + g_{d2} + g_{d1})$$

$$v_{ds1} = v_{s2} = \frac{v_{out}}{m_2 \frac{g_{m2}}{g_{d2}} + 1 + \frac{g_{d1}}{g_{d2}}} \cong \frac{v_{out}}{m_2 g_{m2} r_{d2}} \ll v_{out}$$

Conditions:

V_{out} varies, while V_{in}
stays constant

Cascode structure: effect of V_{out} variations on M1 and M2

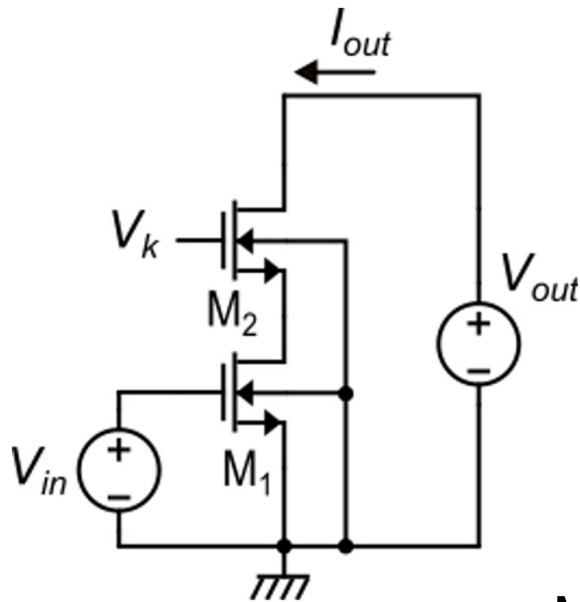

$$v_{ds1} \cong \frac{v_{out}}{m_2 g_{m2} r_{d2}} \ll v_{out}$$

$$v_{out} = v_{ds1} + v_{ds2}$$

$$v_{out} \cong v_{ds2}$$

M2 "protects" M1: V_{DS2} absorbs V_{out} variations which affect V_{DS1} through a great attenuation

As V_{OUT} is reduced, V_{DS1} stays constant and equal to V_{DS1Q} (the quiescent value) until the product $g_{m2}r_{d2}$ is large.

V_{DS2} reduces until it reaches V_{DSAT2} . This happens for:

$$V_{out} \triangleq V_{MIN} = V_{DSAT2} + V_{DS1}$$

Cascode structure: effect of V_{out} variations on M1 and M2

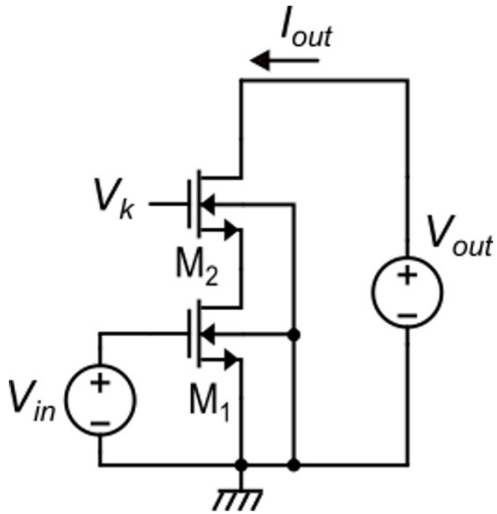

For $V_{OUT} < V_{MIN}$, M2 enters triode region, g_{m2} and r_{d2} decreases.

$$v_{ds1} \cong \frac{v_{out}}{m_2 g_{m2} r_{d2}}$$

get larger and V_{DS1} start decreasing

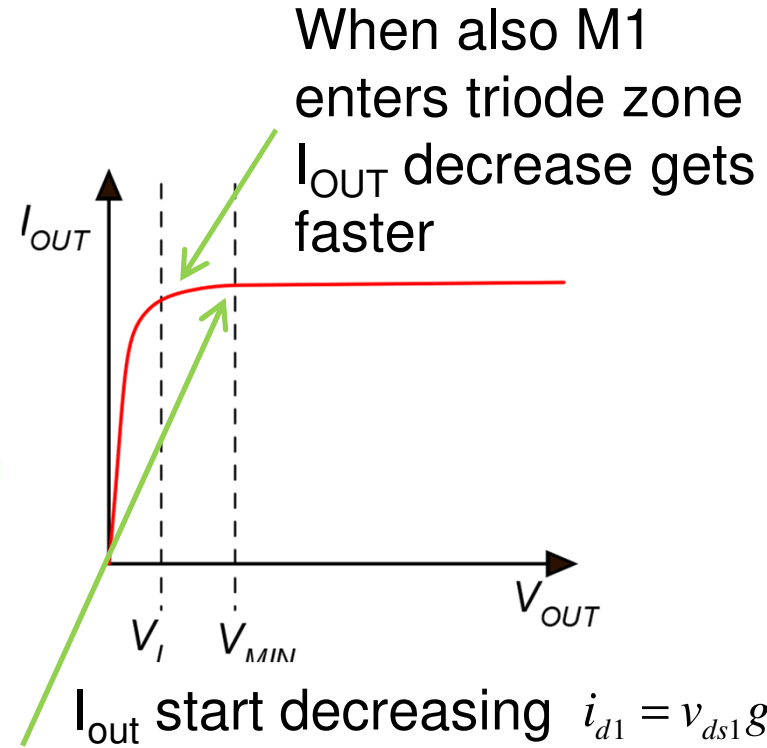
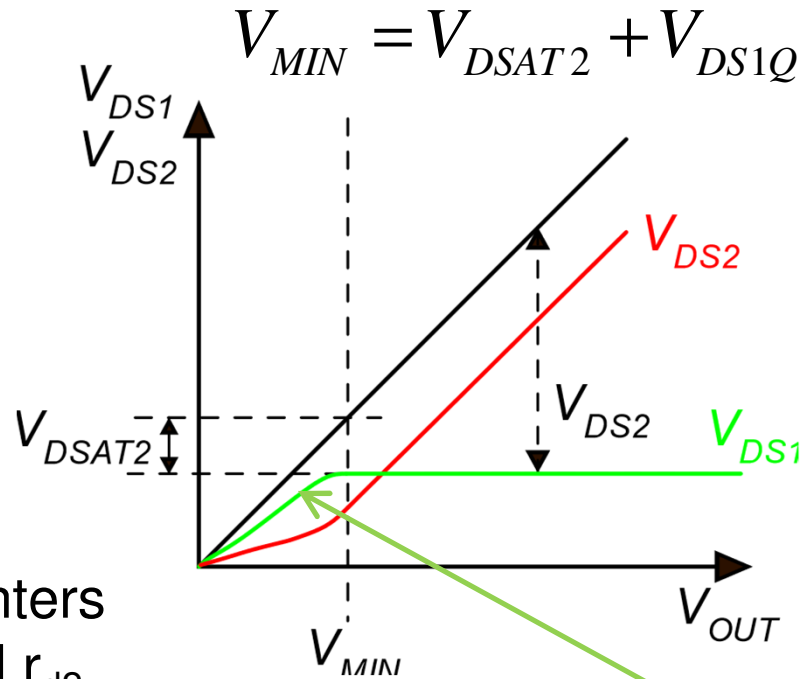

Standard Cascode current mirror

Cascode structure

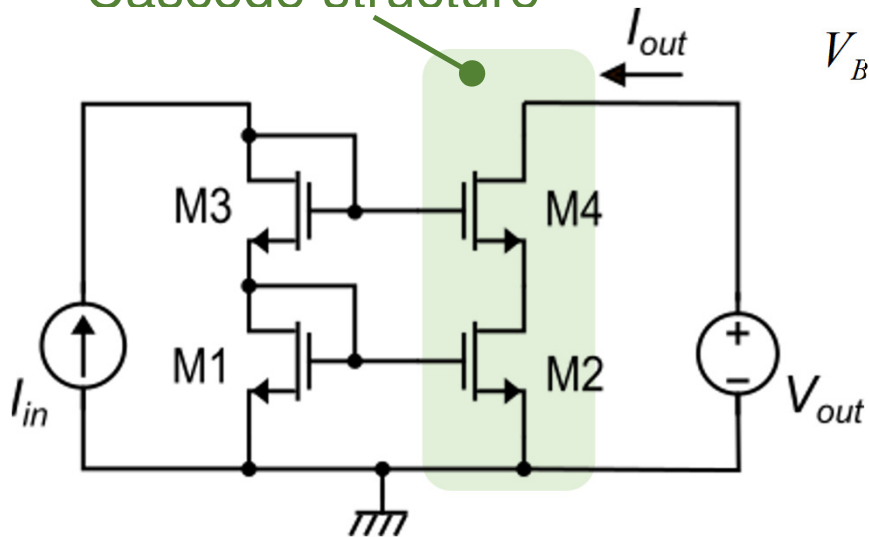

Mosfet body connections

$$V_{B1} = V_{B2} = V_{B3} = V_{B4} \Rightarrow \text{substrate}$$

$$I_{out} = I_{D2} = \beta_2 f \left[(V_{GS} - V_t)_2, V_{DS2} \right]$$

$$I_{in} = I_{D1} = \beta_1 f \left[(V_{GS} - V_t)_1, V_{DS1} \right]$$

$$V_{GS1} = V_{GS2}$$

$$V_{BS1} = V_{BS2}$$

$$\frac{I_{out}}{I_{in}} = \frac{\beta_2}{\beta_1} \triangleq k_M$$

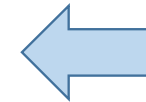

$$(V_{GS} - V_t)_1 = (V_{GS} - V_t)_2$$

$$\text{if: } V_{DS2} = V_{DS1}$$

If we can make $V_{DS2} = V_{DS1}$ in the operating point, then this condition is maintained with a good approximation for all V_{OUT} values $> V_{MIN} = V_{DS2} + V_{DSAT4}$

Standard cascode current mirror: V_{DS2}

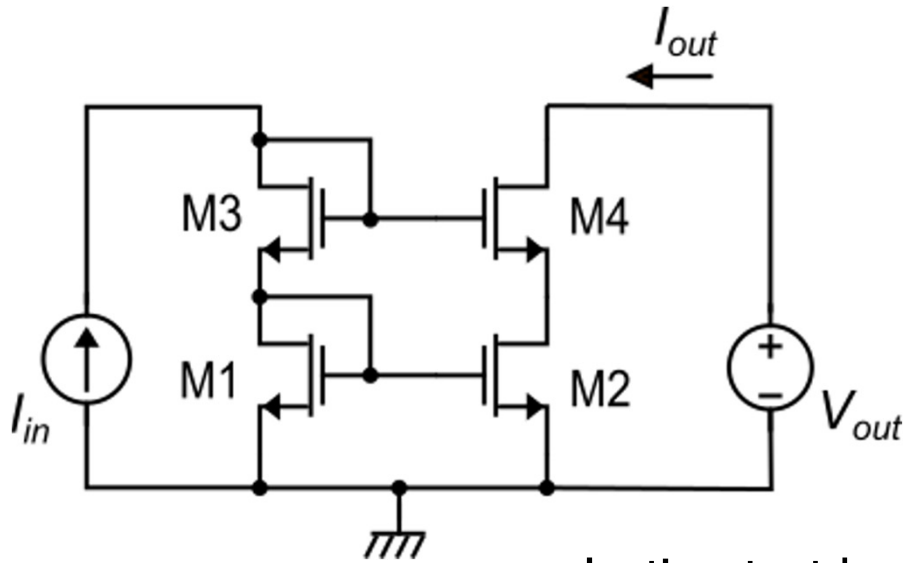

we want to obtain: $V_{DS2} = V_{DS1}$

$$V_{DS2} = V_{G4} - V_{GS4}$$

$$V_{G4} = V_{G3}$$

$$V_{DS1} = V_{G3} - V_{GS3}$$

we need to make: $V_{GS4} = V_{GS3}$

Let's start by making:

$$(V_{GS} - V_t)_4 = (V_{GS} - V_t)_3$$

$$V_{GS4} = V_{t4} + (V_{GS} - V_t)_4$$

$$V_{GS3} = V_{t3} + (V_{GS} - V_t)_3$$

$$I_{D4} = \beta_4 f \left[(V_{GS} - V_t)_4, V_{DS4} \right] \cong \beta_4 f \left[(V_{GS} - V_t)_4 \right]$$

$$I_{D3} = \beta_3 f \left[(V_{GS} - V_t)_3, V_{DS3} \right] \cong \beta_3 f \left[(V_{GS} - V_t)_3 \right]$$

$$f \left[(V_{GS} - V_t)_4 \right] = \frac{I_{D4}}{\beta_4}$$

$$f \left[(V_{GS} - V_t)_3 \right] = \frac{I_{D3}}{\beta_3}$$

$$\frac{I_{D4}}{\beta_4} = \frac{I_{D3}}{\beta_3}$$

Standard cascode current mirror: V_{DS2}

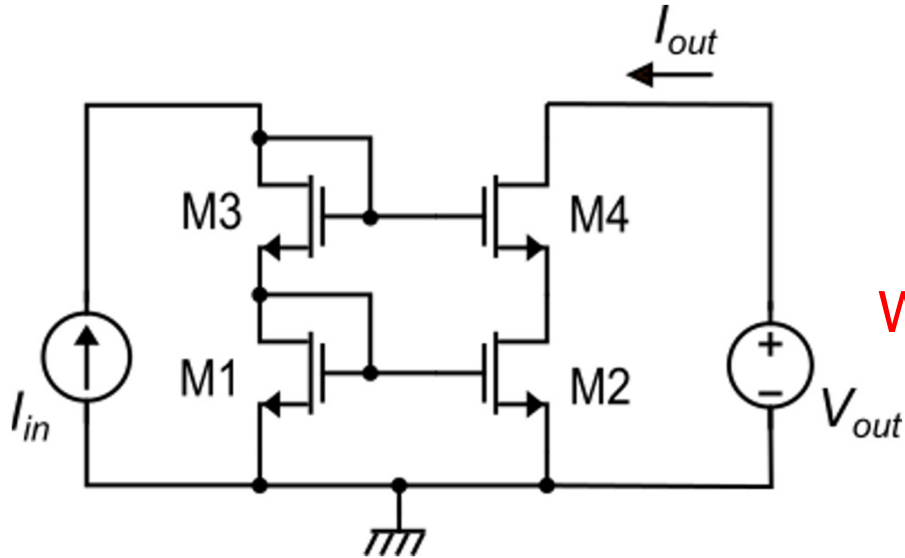

$$V_{DS2} = V_{DS1} \quad \text{We need: } V_{GS4} = V_{GS3}$$

$$V_{t4} + (V_{GS} - V_t)_4 = V_{t3} + (V_{GS} - V_t)_3$$

$$\text{We start by: } (V_{GS} - V_t)_4 = (V_{GS} - V_t)_3 \quad \Rightarrow \quad \frac{I_{D4}}{\beta_4} = \frac{I_{D3}}{\beta_3}$$

$$\frac{\beta_4}{\beta_3} = \frac{I_{D4}}{I_{D3}} = \frac{I_{D2}}{I_{D1}}$$

To get $V_{GS4} = V_{GS3}$ we need also that $V_{t3} = V_{t4}$

In next slide, we will show that the design rule that sets $(V_{GS} - V_t)_4 = (V_{GS} - V_t)_3$ also guarantee that $V_{t3} = V_{t4}$.

Then, the design rule $\frac{\beta_4}{\beta_3} = \frac{\beta_2}{\beta_1}$ is sufficient to obtain $V_{GS4} = V_{GS3}$

$$\frac{\beta_4}{\beta_3} = \frac{\beta_2}{\beta_1} = k_M$$

Design rule

Standard cascode current mirror: V_{DS2}

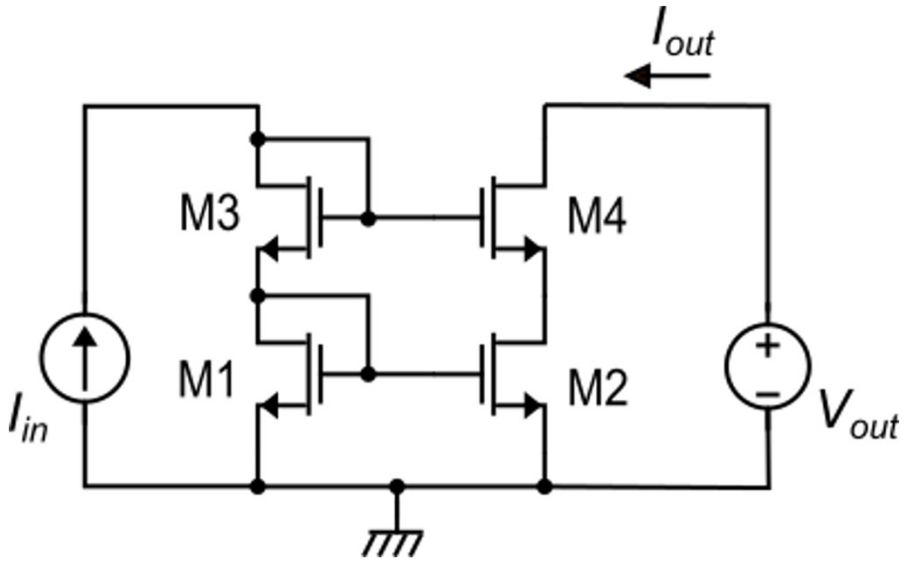

From: $(V_{GS4} - V_{t4}) = (V_{GS3} - V_{t3})$

$$V_{G4} - V_{S4} - V_{t4} = V_{G3} - V_{S3} - V_{t3}$$

$$V_{S3} - V_{S4} = V_{t4} - V_{t3}$$

Proof by contradiction
(reductio ad absurdum):

Hypotesis: $V_{S3} > V_{S4}$

$V_{t4} > V_{t3}$

$V_{SB3} > V_{SB4}$

$V_{t3} > V_{t4}$

Contradiction !

Starting from the opposite hypothesis
($V_{S3} < V_{S4}$) we get a contradiction again:

$V_{S3} = V_{S4}$
 $V_{t3} = V_{t4}$

Standard Cascode current mirror: parameters

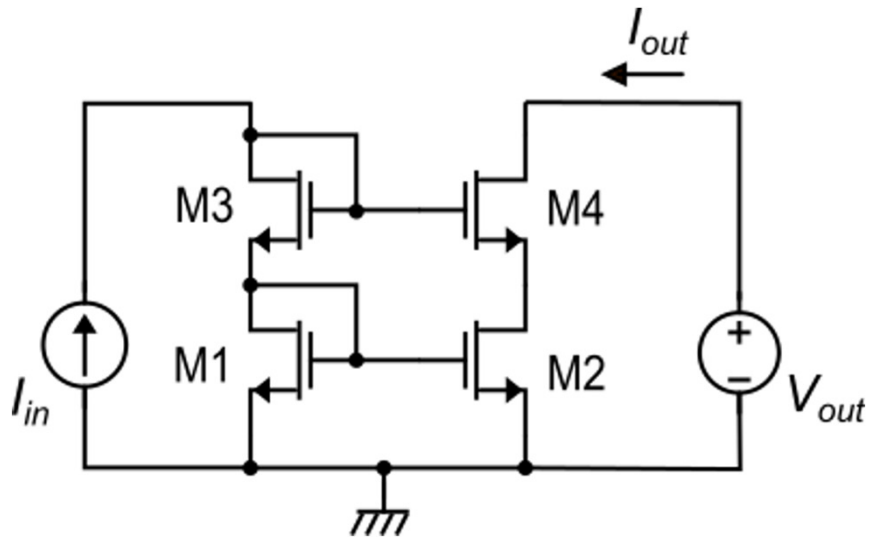

Cascode mirror

$$V_{in} = V_{GS1} + V_{GS3} \approx 2V_{GS}$$

$$V_{MIN} = V_{DS2} + V_{DSAT4}$$

$$V_{DS2} = V_{DS1} = V_{GS1}$$

$$V_{MIN} = V_{GS1} + V_{DSAT4} \approx V_{GS} + V_{DSAT}$$

$$R_{out} \cong r_{d4} (g_{m4} r_{d2}) = \frac{1}{\lambda_4 I_{out}} (g_{m4} r_{d2})$$

$$V_{th} = R_{out} I_{out} = \frac{1}{\lambda_4} (g_{m4} r_{d2})$$

Simple mirror

$$V_{GS}$$

$$V_{DSAT}$$

$$\frac{1}{\lambda_2 I_{out}}$$

$$\frac{1}{\lambda_2}$$

Wide swing cascode mirrors: principle

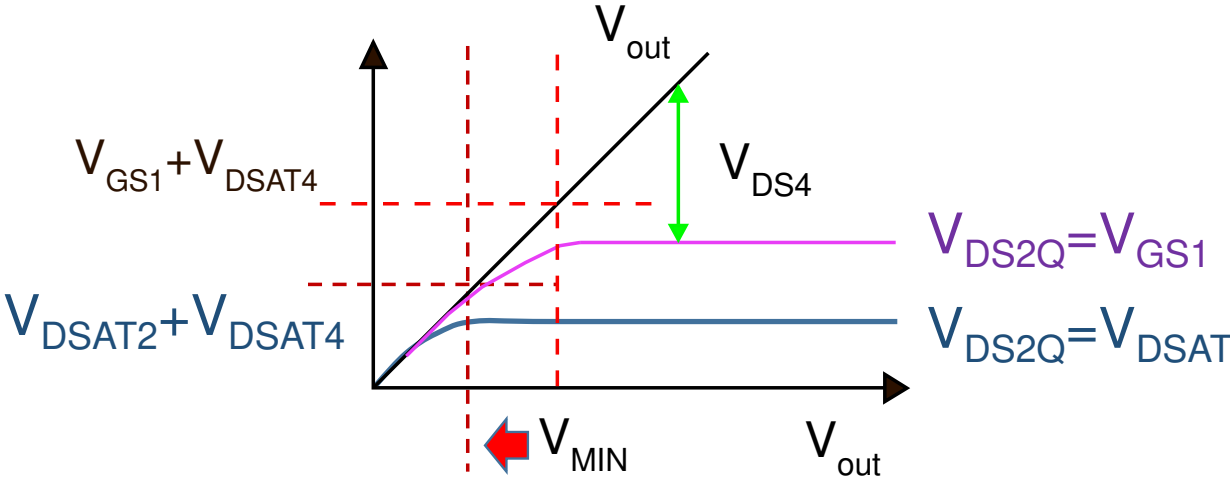
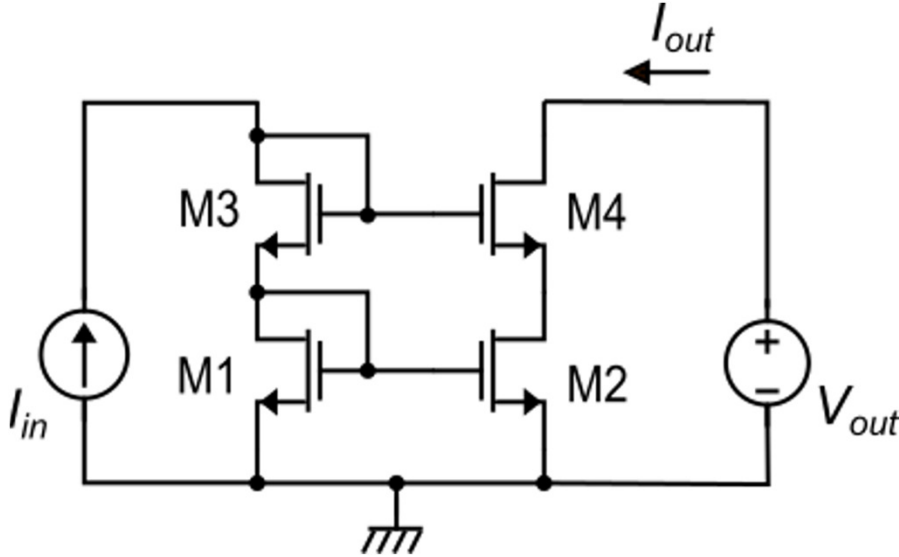

Wide swing cascode mirror: 6 MOSFET mirror

auxiliary branch

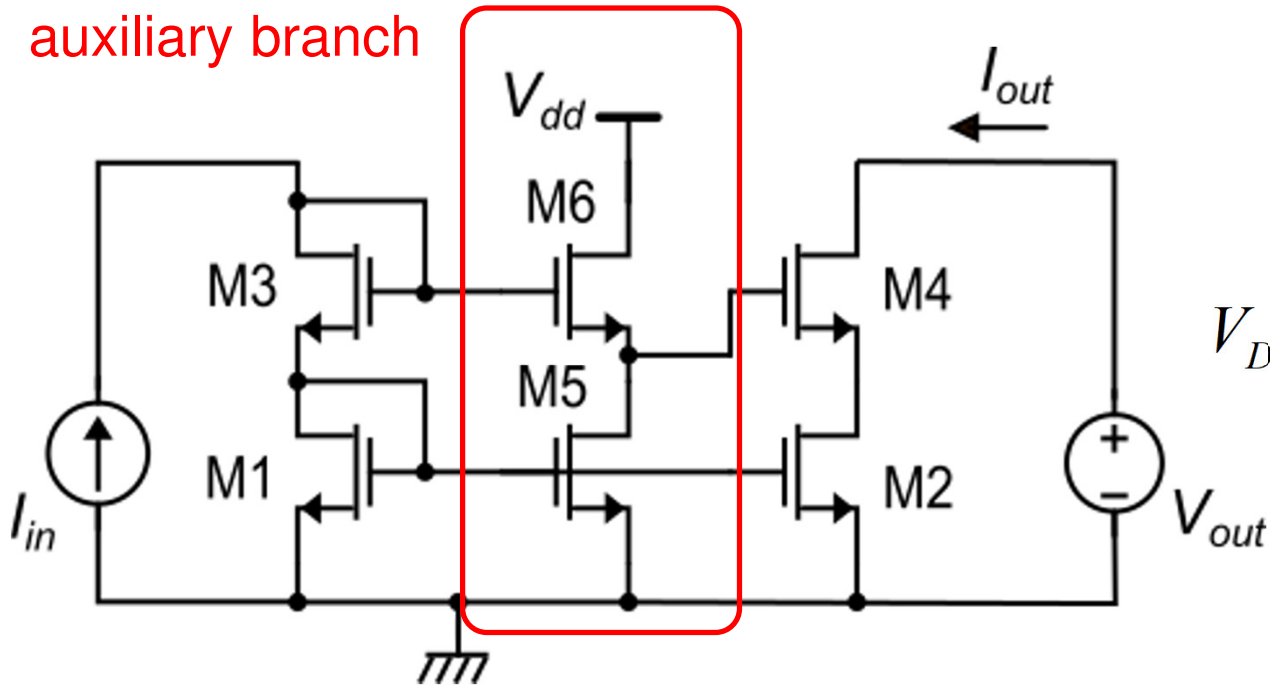

$$k_M = \frac{\beta_2}{\beta_1}$$

$$V_{DS2} = V_{GS1} + V_{GS3} - V_{GS6} - V_{GS4}$$

$$V_{DS2} = (V_{GS} - V_t)_1 + (V_{GS} - V_t)_3 - (V_{GS} - V_t)_6 - (V_{GS} - V_t)_4 +$$

$$+ \cancel{V_{t1} + V_{t3} - V_{t6} - V_{t4}}$$

$$V_{t1} + V_{t3} - V_{t6} - V_{t4} \cong 0$$

Wide swing cascode mirror: 6 MOSFET mirror

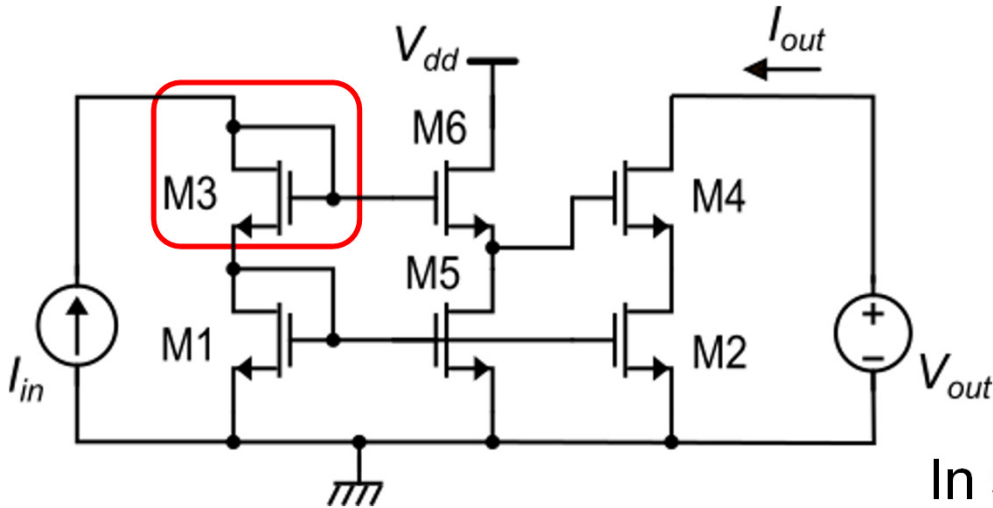

$$V_{DS2} \cong (V_{GS} - V_t)_1 + (V_{GS} - V_t)_3 - (V_{GS} - V_t)_6 - (V_{GS} - V_t)_4$$

In strong inversion:

$$V_{MIN} = V_{DS2Q} + V_{DSAT4}$$

$$\underline{\underline{V_{MIN} = V_{DSAT2} + V_{DSAT4}}}$$

Choices:

- $I_{D5} = I_{D1}$ ($= I_{D6}$)
- $\beta_6 = \beta_1$
- $\beta_4 = k_M \beta_1$
- $\beta_3 = \beta_1 / 4$

$$V_{DS2} \cong \sqrt{\frac{2I_{D1}}{\beta_1}} + \sqrt{\frac{2I_{D3}}{\beta_3}} - \sqrt{\frac{2I_{D6}}{\beta_6}} - \sqrt{\frac{2I_{D4}}{\beta_4}}$$

$$V_{DS2} = \sqrt{\frac{2I_{D1}}{\beta_1}} + \sqrt{4 \frac{2I_{D1}}{\beta_1}} - \sqrt{\frac{2I_{D1}}{\beta_1}} - \sqrt{\frac{2k_M I_{D1}}{k_M \beta_1}} = \sqrt{\frac{2I_{D1}}{\beta_1}} = (V_{GS1} - V_t) = V_{DSAT2}$$

High precision – wide swing cascode mirror

Required to bias M1 gate with the right voltage to make M1 carry I_{in}

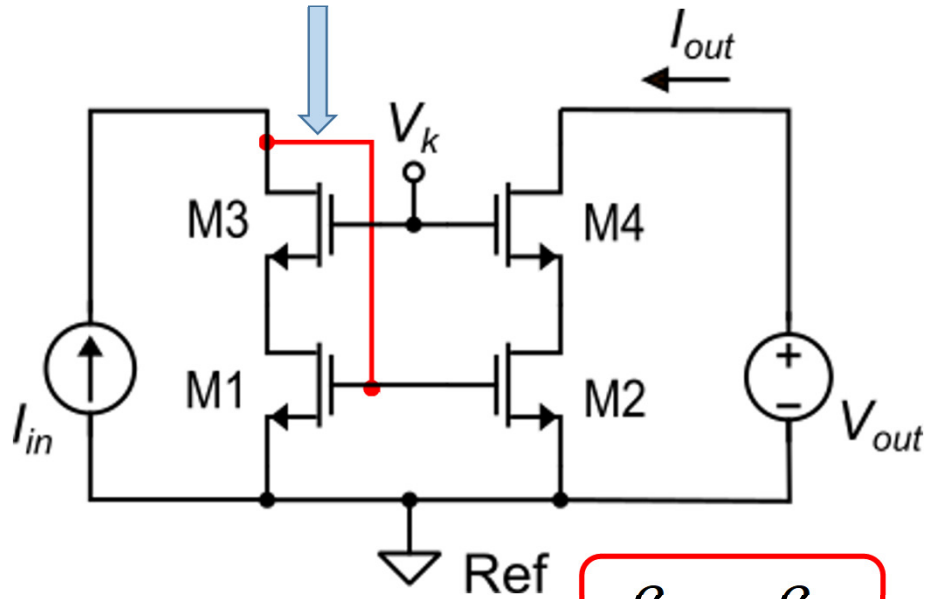

$$\frac{\beta_4}{\beta_3} = \frac{\beta_2}{\beta_1}$$

$$V_{GS2} = V_{GS1}$$

if also: $V_{DS2} = V_{DS1} \Rightarrow \frac{I_{out}}{I_{in}} = \frac{\beta_2}{\beta_1} = k_M$

$$\begin{cases} V_{DS1} = V_k - V_{GS3} \\ V_{DS2} = V_k - V_{GS4} \end{cases} \quad \text{Voltages are referred to } V_{Ref}$$

$$V_{DS2} = V_{DS1} \Leftrightarrow V_{GS3} = V_{GS4}$$

Repeating the same considerations made for the standard cascode mirror

High precision – wide swing cascode mirror

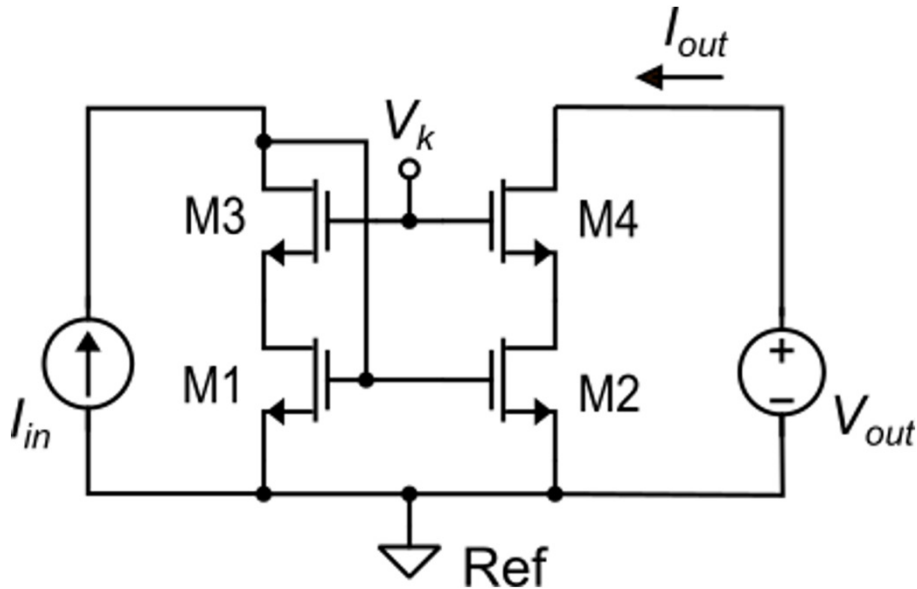

$$\begin{cases} V_{DS1} = V_k - V_{GS3} \\ V_{DS2} = V_k - V_{GS4} \end{cases} \quad \leftarrow \text{ Voltages are referred to } V_{\text{Ref}}$$

$$V_{GS4} = V_{t4} + (V_{GS} - V_t)_4$$

$$V_{GS4} \cong V_{t0} + (m_4 - 1)V_{SB4} + (V_{GS} - V_t)_4$$

$$V_{GS4} = V_{t0} + (m_4 - 1)V_{S4} - (m_4 - 1)V_{B4} + (V_{GS} - V_t)_4$$

All substrates are connected to the same potential V_B

$$V_{DS2} = \underline{V_{S4}} = V_k - V_{t0} - \underline{(m_4 - 1)V_{S4}} + (m_4 - 1)V_B - (V_{GS} - V_t)_4$$

$$V_k = mV_{DS2} + V_{t0} + (V_{GS} - V_t)_4 - (m_4 - 1)V_B$$

Bias of a wide-swing cascode structure

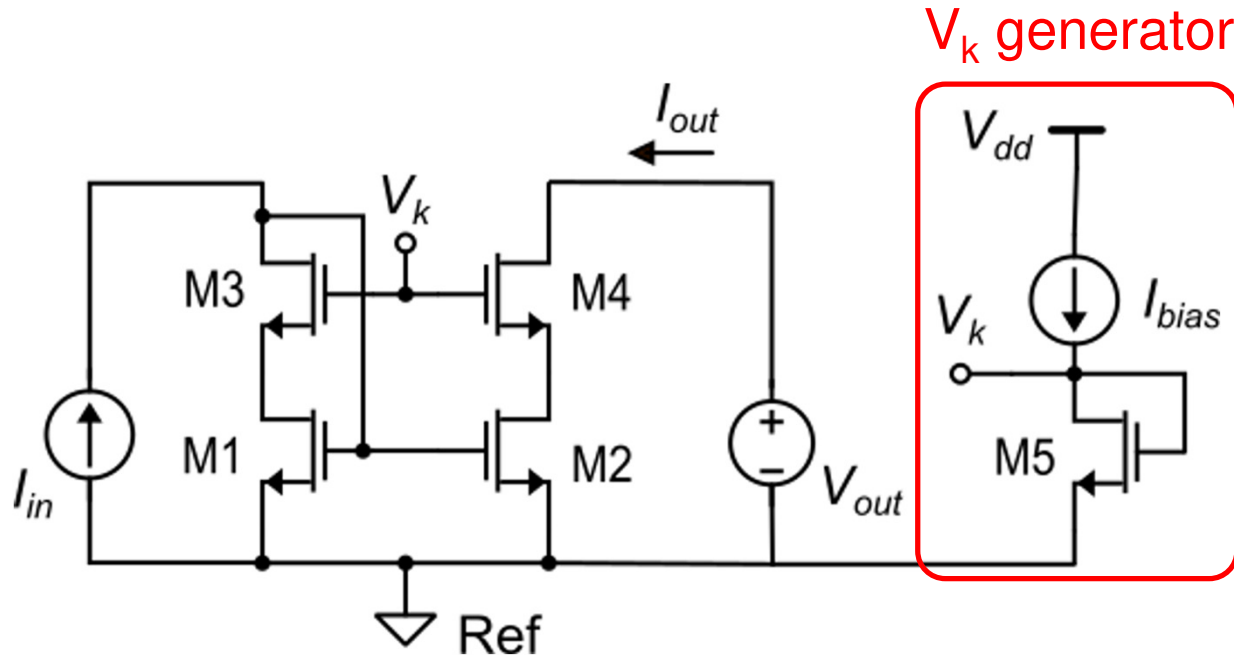

$$V_k = V_{GS5}$$

$$V_{GS5} \cong V_{t0} + (m_5 - 1)V_{SB5} + (V_{GS} - V_t)_5$$

$$V_{GS5} \cong V_{t0} + \cancel{(m_5 - 1)V_{S5}} - \cancel{(m_5 - 1)V_{B5}} + (V_{GS} - V_t)_5$$

$$m_4 \cong m_5$$

$$V_k = mV_{DS2} + \cancel{V_{t0}} + (V_{GS} - V_t)_4 - \cancel{(m_4 - 1)V_B}$$

$$V_{GS5} \cong \cancel{V_{t0}} - \cancel{(m_5 - 1)V_B} + (V_{GS} - V_t)_5$$

$$\Rightarrow (V_{GS} - V_t)_5 = mV_{DS2} + (V_{GS} - V_t)_4$$

Bias of a wide-swing cascode structure

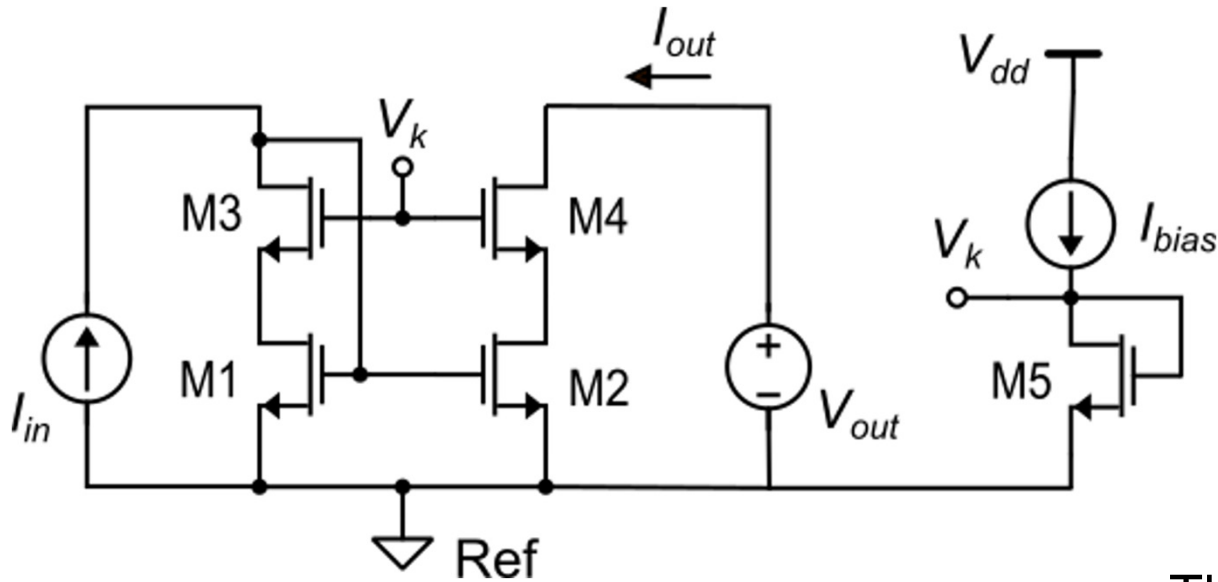

$$V_{MIN} = V_{DS2} + V_{DSAT4}$$

Best (minimum) V_{MIN}

$$V_{DS2} = V_{DSAT2}$$

$$V_{MIN} = V_{DSAT2} + V_{DSAT4} \approx 2V_{DSAT}$$

$$V_{IN} = V_{GS1}$$

$$(V_{GS} - V_t)_5 = m_4 V_{DSAT2} + (V_{GS} - V_t)_4$$

In Strong inversion: $V_{DSAT2} = (V_{GS} - V_t)_2$

$$(V_{GS} - V_t)_5 = m_4 (V_{GS} - V_t)_2 + (V_{GS} - V_t)_4$$

The precision wide-swing cascode offers similar V_{MIN} and same V_{IN} of a simple mirror with much higher output resistance and accuracy

p-version of the precision wide swing cascode mirror

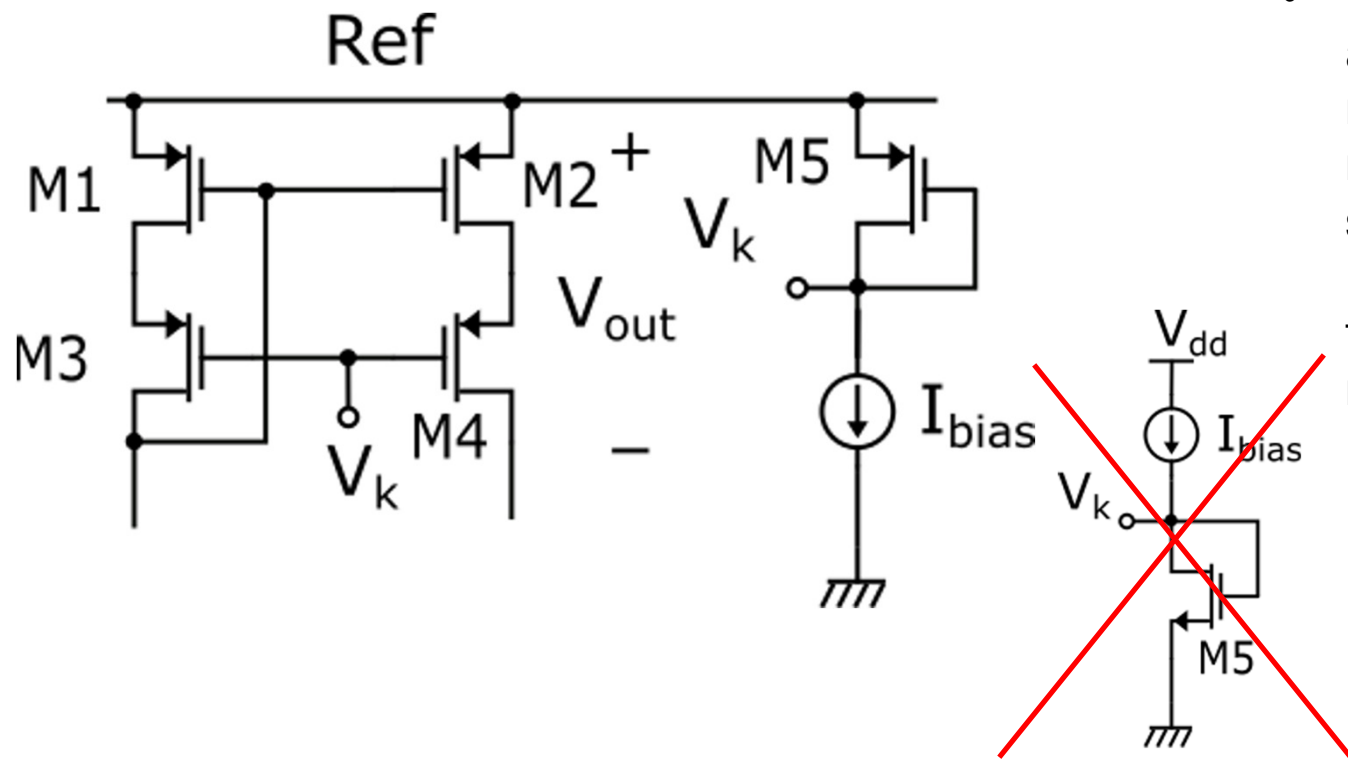

Very important rule:

- Voltage V_k must be invariant against V_{dd} variations when measured using Ref as the reference voltage. (i.e. V_k should be referred to node Ref.) The circuit shown in the picture satisfies this requirement.