

A small-signal method to calculate the effect of component variations

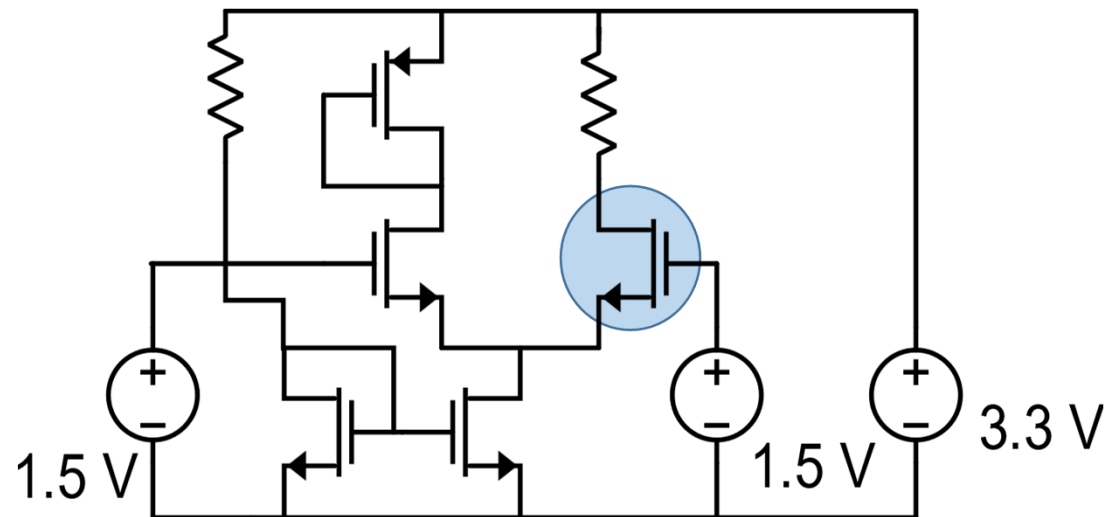

Example of non-linear network

The problem is: if we consider the dc solution of a network, what happens to this solution if the parameters of one or more devices undergo a small change

Small signal approach to parameter variations

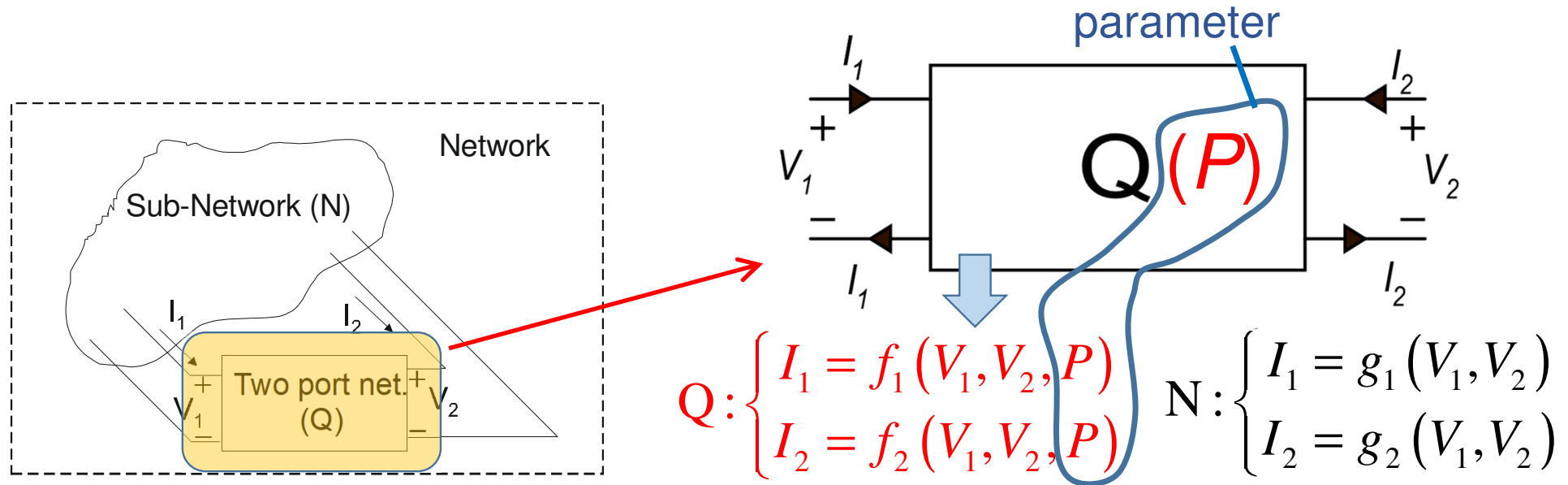

We consider that the component whose parameters change can be represented by a two-port network

Both the selected two-port network (Q) and the remaining network (N) can be highly non-linear (g_1, g_2, f_1, f_2 : non-linear)

$P \Rightarrow P + \Delta P$ \Rightarrow Variation of the network solution

Approximate solution based on small signal analysis

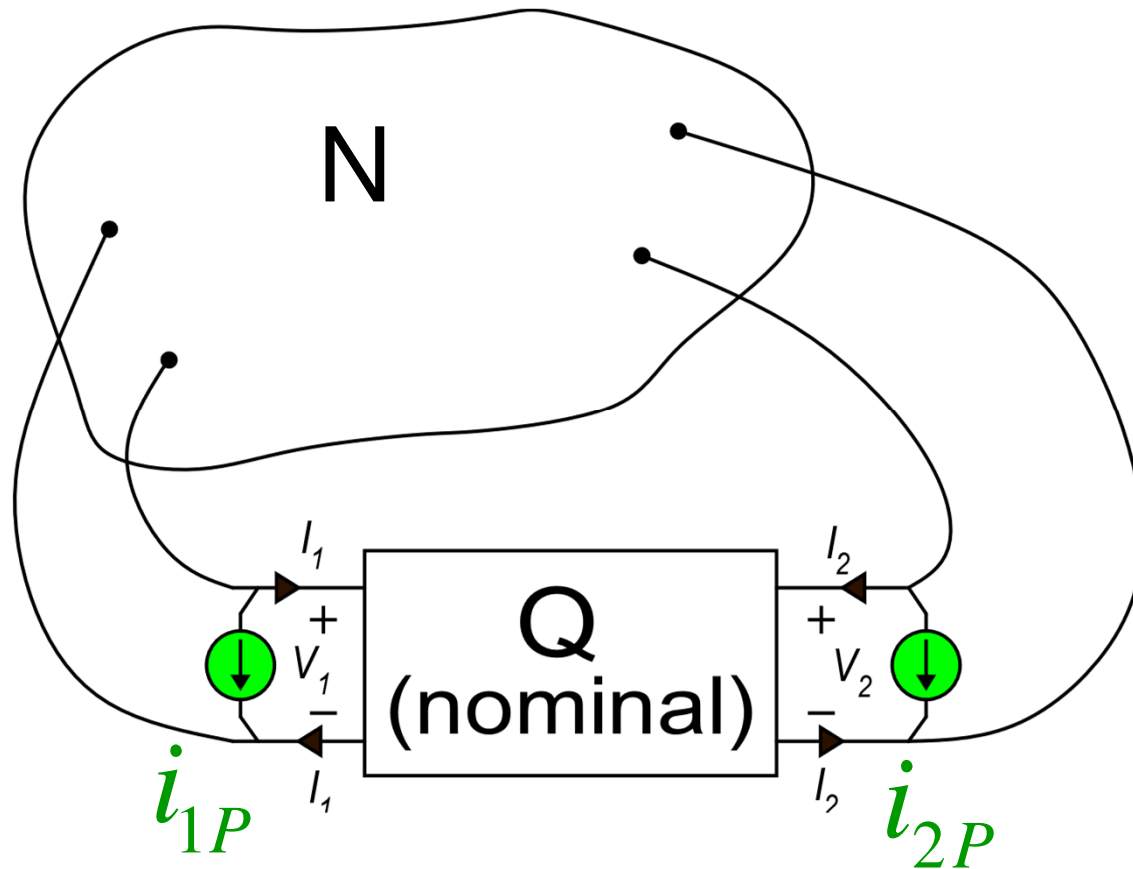

Apply two-currents to the nominal network, as in the figure, with values:

$$i_{1P} = \frac{\partial I_1}{\partial P} \Delta P \quad i_{2P} = \frac{\partial I_2}{\partial P} \Delta P$$

The variations caused by the change $P \rightarrow P + \Delta P$ can be calculated solving the small-signal circuit of the whole network with the only independent sources i_{1P} and i_{2P} .

Example of parameter change: resistance change

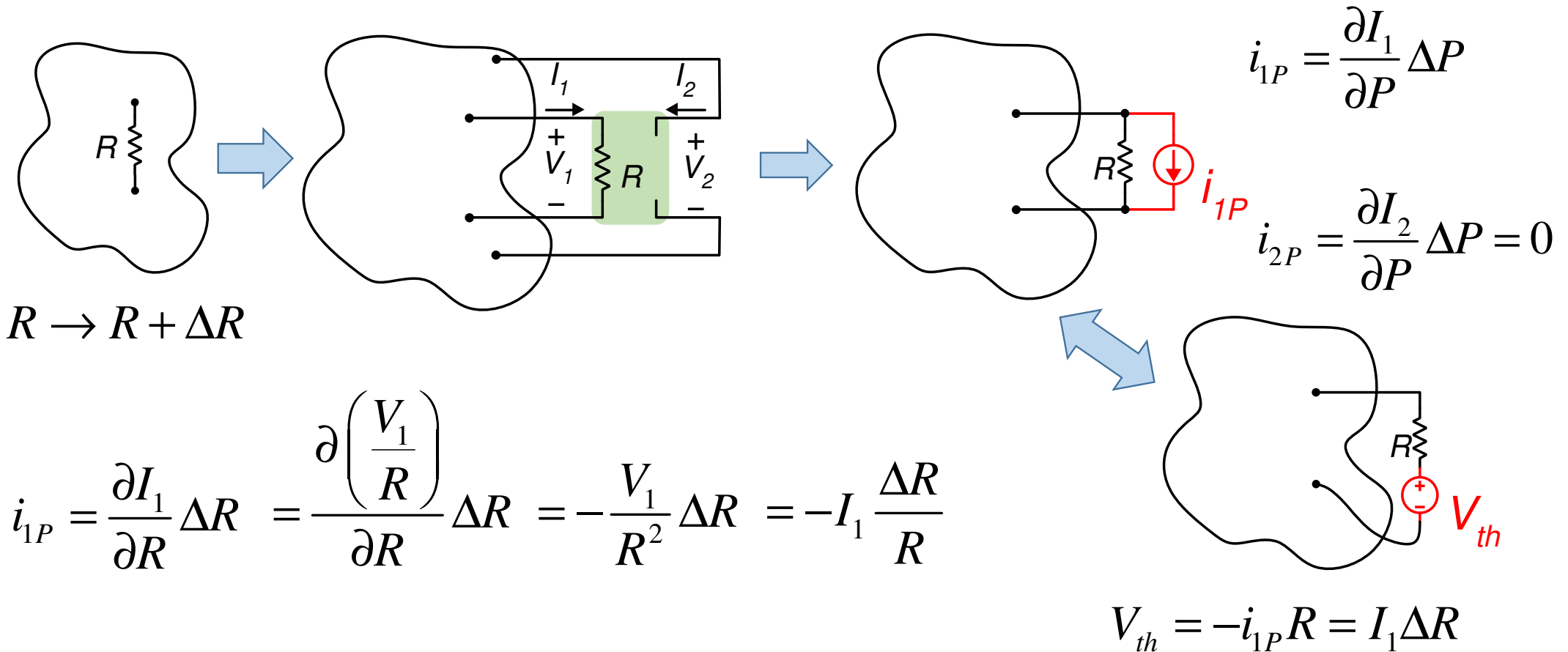

MOSFET

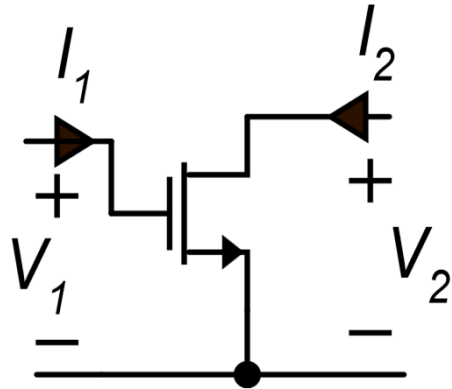

$P: V_t, \beta$

$$I_1 = I_G = 0$$

$$I_2 = I_D$$

$$V_1 = V_{GS}$$

$$V_2 = V_{DS}$$

$$i_{1P} = \frac{\partial I_g}{\partial P} \Delta P = 0$$

$$i_{2P} = \frac{\partial I_D}{\partial P} \Delta P$$

$$i_{2P} = \frac{\partial I_D}{\partial \beta} \Delta \beta + \frac{\partial I_D}{\partial V_t} \Delta V_t$$

MOSFET: strong inversion + saturation

nominal device

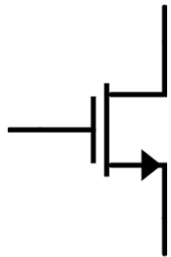

V_t, β nominal parameters

V_{GS}, V_{DS}, I_D nominal operating point

actual device

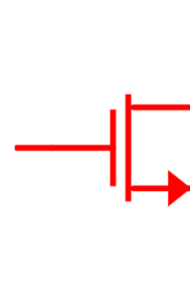

$V_t + \Delta V_t, \beta + \Delta\beta$

$$I_D \cong \frac{\beta}{2} (V_{GS} - V_t)^2$$

nominal device

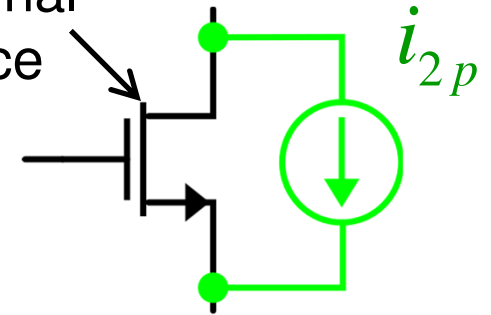

$$i_{2p} = \frac{\partial I_D}{\partial \beta} \Delta\beta + \frac{\partial I_D}{\partial V_t} \Delta V_t = \frac{1}{2} (V_{GS} - V_t)^2 \Delta\beta - \beta (V_{GS} - V_t) \Delta V_t$$

MOSFET: strong inversion + saturation

$$i_{2p} = \underbrace{\frac{1}{2}(V_{GS} - V_t)^2 \Delta\beta}_{\frac{\beta}{2}(V_{GS} - V_t)^2 \frac{\Delta\beta}{\beta}} - \underbrace{\beta(V_{GS} - V_t) \Delta V_t}_{\frac{2}{(V_{GS} - V_t)} \frac{\beta}{2}(V_{GS} - V_t)^2 \Delta V_t}$$

$$i_{2p} = I_D \left[\frac{\Delta\beta}{\beta} - \frac{2\Delta V_t}{(V_{GS} - V_t)} \right] \stackrel{\text{DEF}}{=} \Delta I_D$$

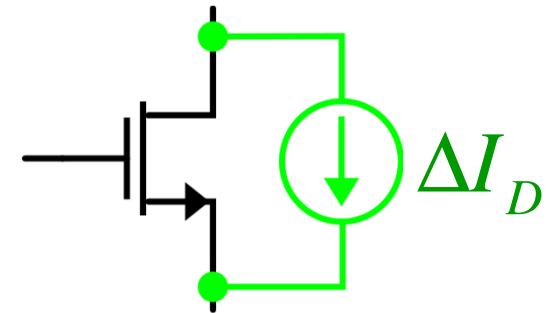

Matched devices

Quantity of interest

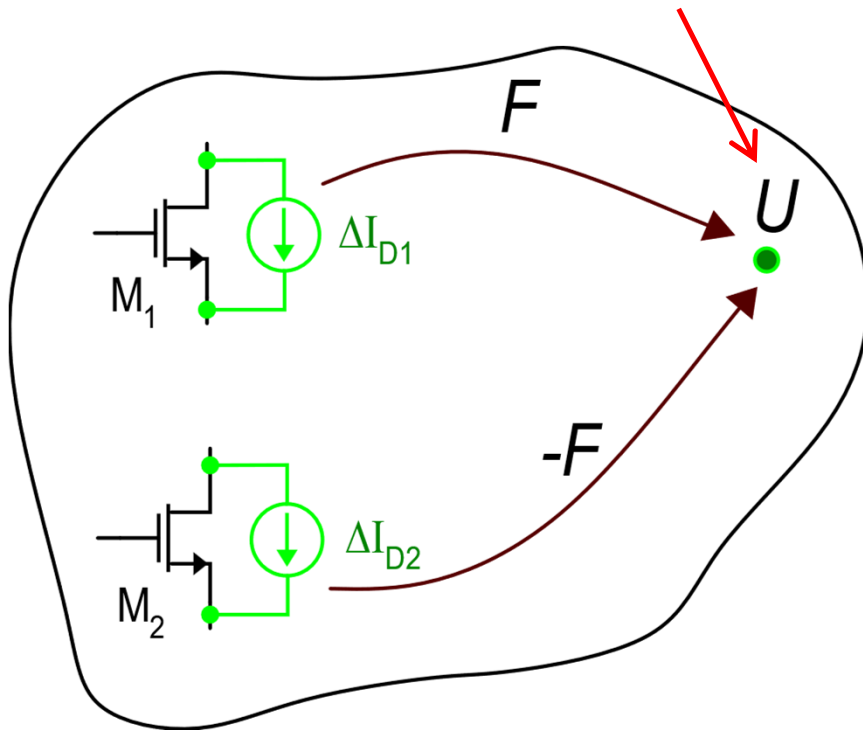

1. The two device are nominally identical.
2. The nominal bias conditions (quiescent currents and voltages) are identical.
3. The nominal transfer functions that tie the quantity of the interest for the circuit (for example the output voltage of an amplifier) to the parametric currents of the two devices (ΔI_{D1} and ΔI_{D2}) are opposite.

$$\Delta U = F (\Delta I_{D1} - \Delta I_{D2}) = F \Delta I_{D1,2}$$

Matched devices

$$P_1 = P_N + \Delta P_1$$

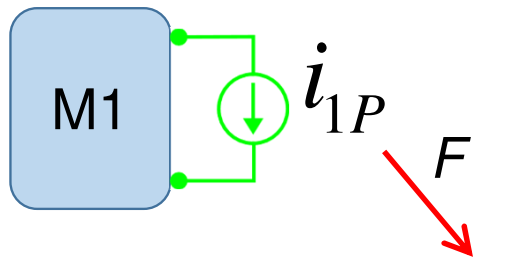

$$P_2 = P_N + \Delta P_2$$

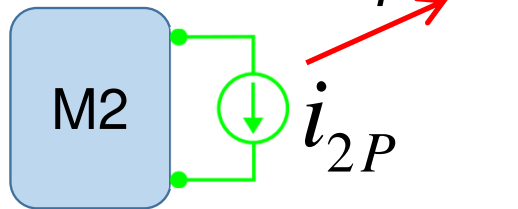

$$\Delta U = F (i_{1P} - i_{2P}) = F \left(\frac{\partial I}{\partial P} \Delta P_1 - \frac{\partial I}{\partial P} \Delta P_2 \right)$$

Same functions, calculated at the same operating point because the device are matched

$$\Delta U = F \frac{\partial I}{\partial P} (\Delta P_1 - \Delta P_2) = F \frac{\partial I}{\partial P} [P_1 - P_N - (P_2 - P_N)]$$

$$\Delta U = F \frac{\partial I}{\partial P} (P_1 - P_2) \quad (P_1 - P_2) \stackrel{\text{DEF}}{=} \Delta P_{1,2}$$

Matched Mosfets

Combined effect of two matched MOSFETs

$$\Delta U = F (\Delta I_{D1} - \Delta I_{D2}) = F \Delta I_{D1,2}$$

$$\Delta I_{D1,2} = I_D \left(\frac{\Delta \beta_{1,2}}{\beta} - \frac{2\Delta V_{t1,2}}{(V_{GS} - V_t)} \right)$$

$$\Delta \beta_{1,2} = \beta_2 - \beta_1$$

$$\Delta V_{t1,2} = V_{t2} - V_{t1}$$

Effect of parameter change of a single device:

$$F \Delta I_D = I_D \left(\frac{\Delta \beta}{\beta} - \frac{2\Delta V_t}{(V_{GS} - V_t)} \right)$$

$$|\Delta \beta_{1,2}| \ll |\Delta \beta_1|, |\Delta \beta_2|$$

$$|\Delta V_{t1,2}| \ll |\Delta V_{t2}|, |\Delta V_{t1}|$$

Norton equivalent circuit with dc component

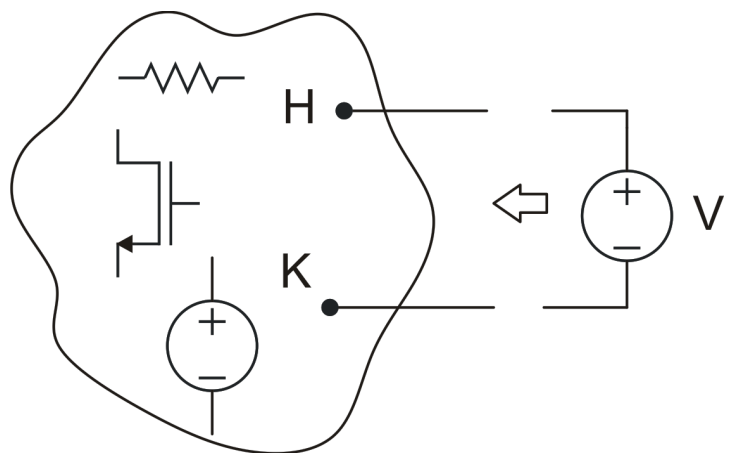

Probing a non-linear network with an arbitrary voltage source V

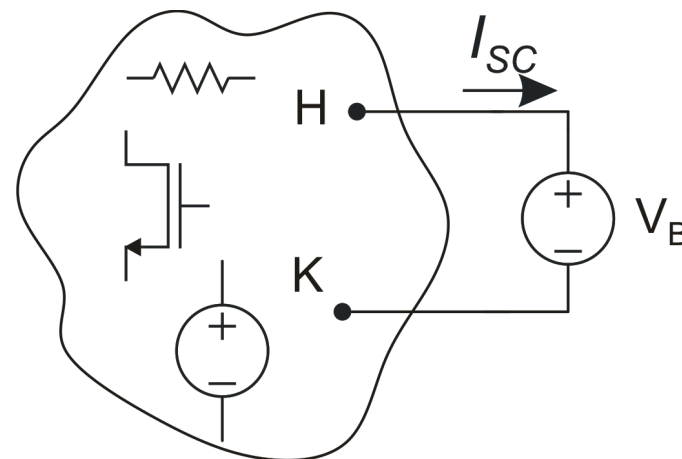

Test 1. Short circuit current when the probing source assumes a voltage V_B . (complete solution, including dc components)

Norton equivalent circuit with dc component

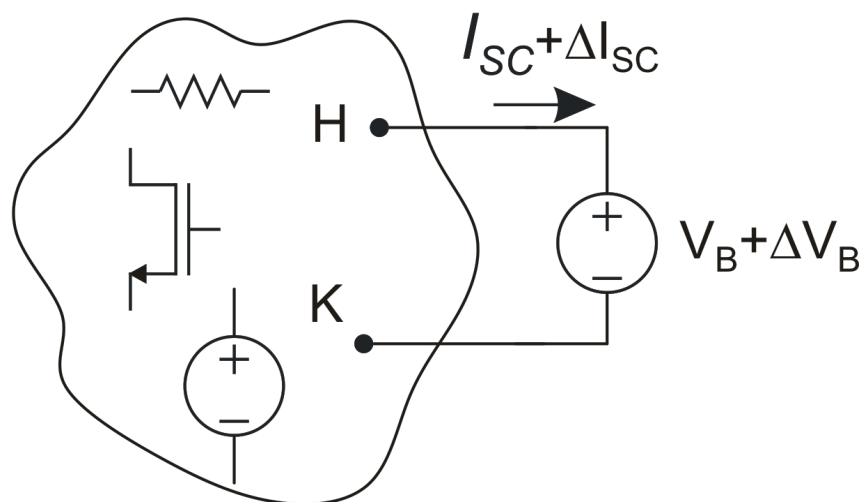

$$R_{out} = \frac{\Delta V_B}{-\Delta I_{SC}}$$

Note: R_{out} is the small-signal resistance seen across terminals H-K in the operating point forced by imposing voltage V_B across H-K terminals

Equivalent circuit of the network

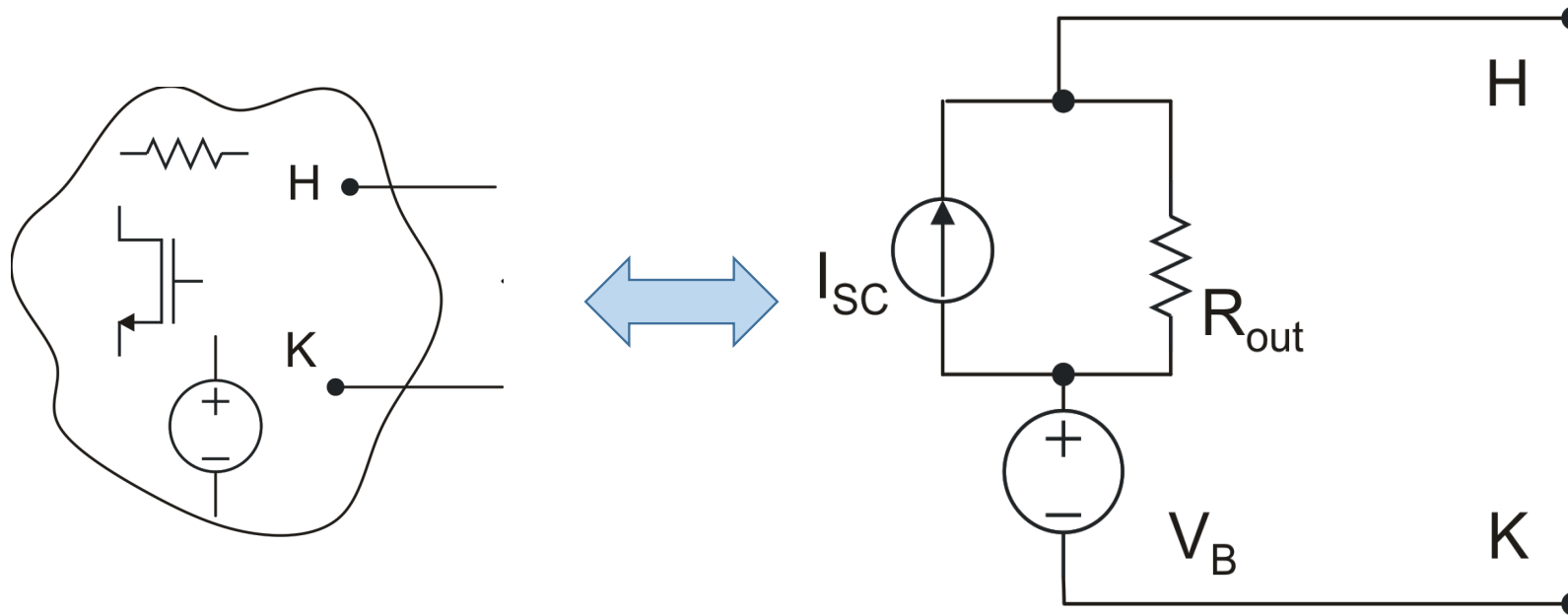

The equivalent circuit is valid until voltage V_{HK} is close enough to V_B that the output resistance does not change significantly

Example: equivalent circuit of the output termination of a real amplifier

