

Chapter 1. Concepts and definitions about Data Acquisition Systems

Electronic systems

An electronic systems is a complex electronic network, which interacts with the physical world through sensors (input devices) and actuators (output devices). This definition is graphically represented in Fig.1.1, where the arrows indicate information fluxes. The aim of the electronic systems is generally to get information about selected aspects of the physical world and, optionally, use the information to modify the physical world in a useful way. The main operations that an electronic system can perform are listed in Fig.1.1.

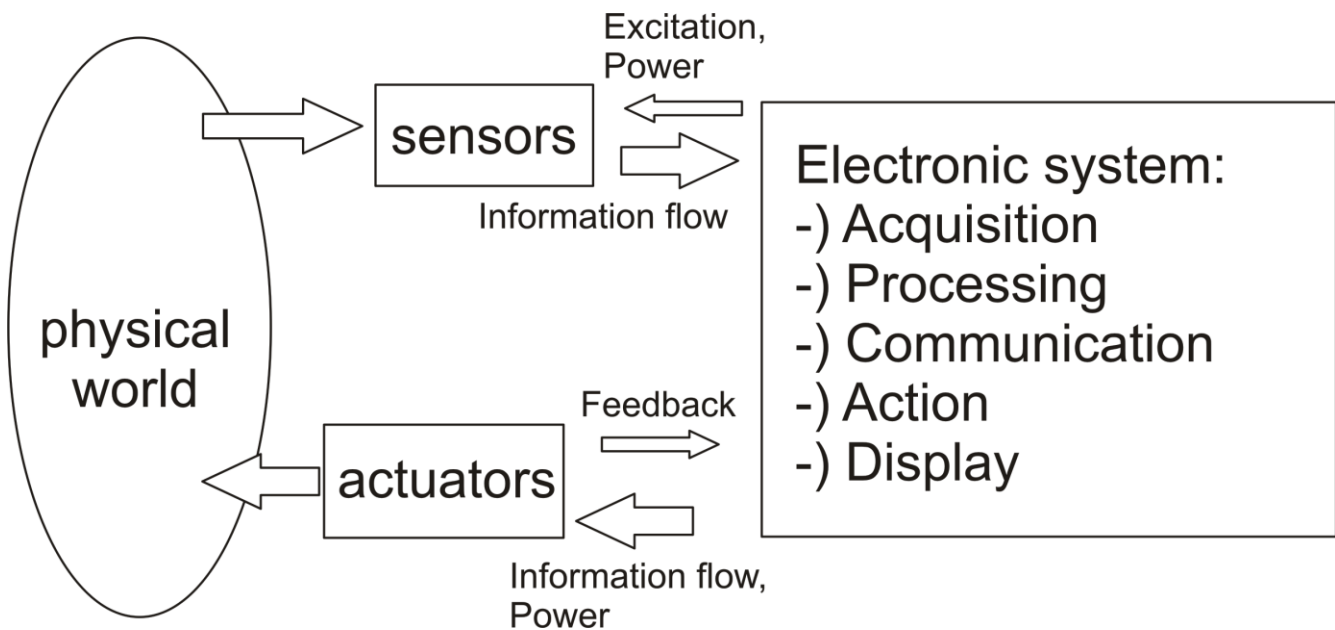

Fig.1.1

The general architecture of an electronic system is shown in fig.1.2. The sensors are handled by the DAS sub-system. The DAS output is a digital signal which is read by a digital processor. The aim of the latter is completing the acquisition process by estimating the quantities of interest. The information is further processed in order to make it suitable for being transmitted, stored or displayed. The digital processor also uses the estimated quantities to calculate the correct action to be applied to the physical world in order to obtain the desired function (e.g. to set the ambient temperature to a given set-point). Data transmission is performed by a communication interface, which implements the required protocol. Other subsystems (peripheral interfaces) allow communication with the storage and display devices, providing the correct protocol and power. The analog power signals which are typically required for driving the actuators are also generated by special subsystems (actuator drivers). The design of a complex electronic system generally requires different skills. The DAS involves advanced analog design techniques; the digital processor requires designers with both knowledge of informatics and automatic digital synthesis; the actuator drivers and peripheral drivers involve power electronics design skills, while the communication interface may require the skill of an RF designer.

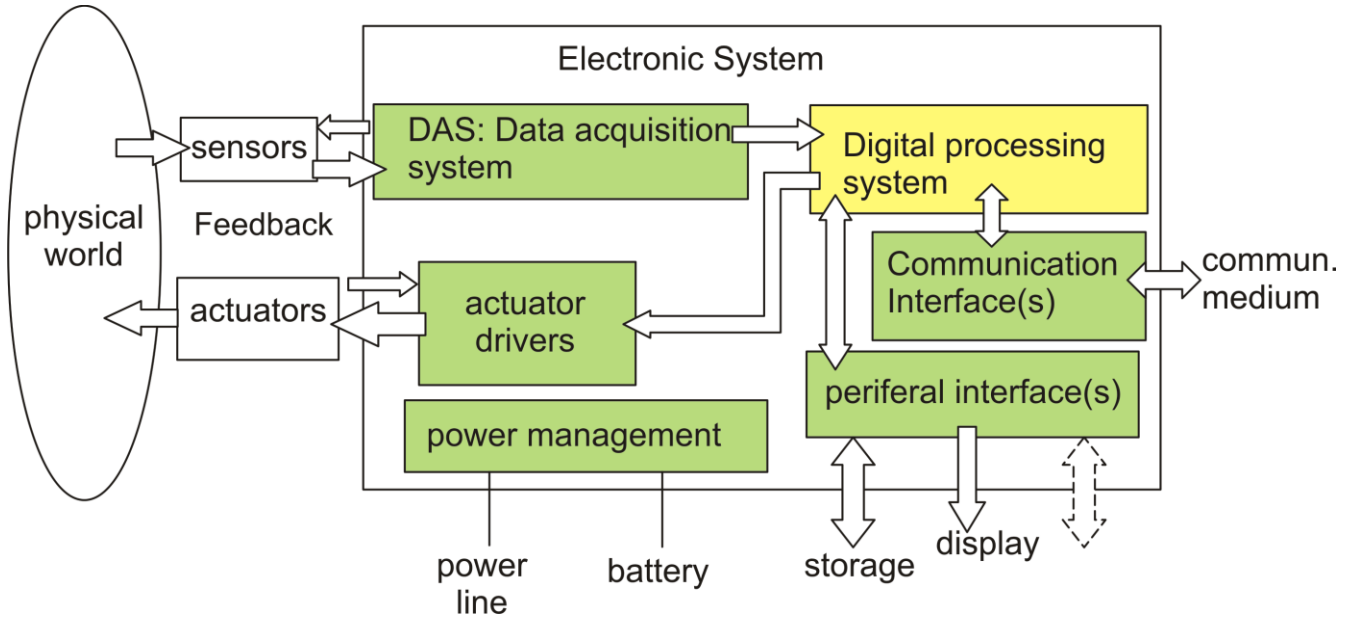

Fig.1.2

Data acquisition systems (DAS).

The aim of a DAS is acquiring information on real world objects by measuring the physical and chemical quantities of interest. For simplicity, in the following part of this document we will simply indicate these quantities with “physical quantities” or, when there is no ambiguity, only with “quantities”. The object, to which the quantities are pertinent, will be indicated as physical world or physical domain. The acquired quantities are converted into an analog electrical signal, generally a voltage. In most cases it is necessary to convert the analog signals into digital signals in order to facilitate processing, storage, visualization and transmission.

Fig. 1.3 shows the various transformations that the information (quantities X and Y) undergoes during the acquisition process. At the end of the process, we get two numbers X_m and Y_m that represent estimates of the quantities X and Y. We have also introduced a third quantity, Z, that we suppose can be calculated from X and Y, so that it is not necessary to build an acquisition channel also for Z but the Z estimate (Z_m), can be simply derived from X_m and Y_m . With this choice, X_m and Y_m are independent quantities, while Z_m is a dependent quantity.

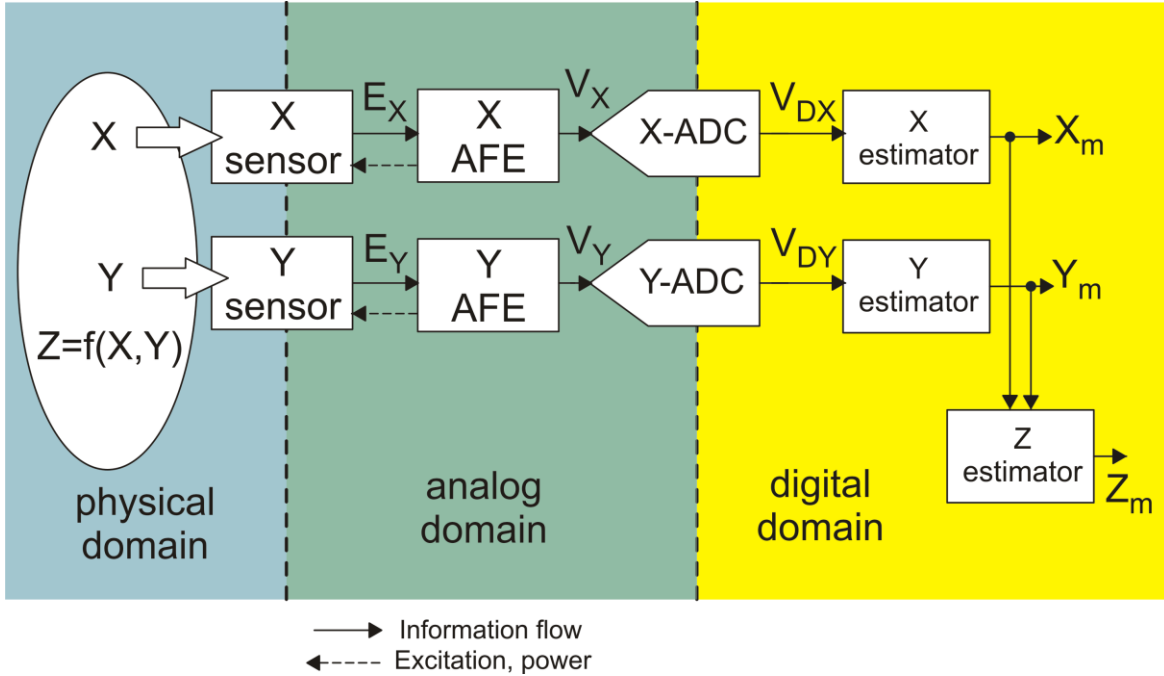

Fig.1.3

Each independent quantity is acquired by a readout channel. A channel is composed by the cascade of several elements: Considering the X readout channel we have:

- **Sensor.** The sensor interacts with the physical quantity of interest (X), causing an electrical quantity E_X to depend on X. In order to unambiguously estimate the X value, the relationship from X to E_X should be monotonic in the whole range of X vales of interest. Note that E_X can be any electrical quantity; typical cases are: voltage, current, resistance and capacitance.
- **AFE (Analog Front End),** also named “interface”. The aim of this block is to convert the quantity E_X produced by the sensor into a signal V_X (typically a voltage), suitable to be easily converted into a digital signal. The AFE may include several functions such as conversion (i.e. from resistance to voltage), amplification, filtering (to eliminate out of band noise and interfering signals), temperature compensation. For many sensor categories, the AFE should also provide the sensors with proper stimuli, necessary for the conversion mechanism. In the case that the sensor response is strongly non-linear, it might be convenient to operate linearization in the analog domain (i.e. inside the AFE), although linearization as well as other non linear operations are preferably performed in the digital domain.
- **Analog-to-digital converter (ADC).** This block is necessary to produce a digital representation of V_X , that we will indicate with V_{XD} . Clearly, the output of the ADC is a code (digital number), but this number represents the input quantity through the ADC transfer characteristics. V_{XD} is different from V_X due to the quantization error and to other ADC errors (offset, gain and non-linearity errors)..
- **X-estimator.** This block implements a numerical algorithm or formula that gets the data from the ADC and calculates the number X_m , consisting in an estimate of X.

Dependent quantities, such as Z, can be derived from X_m and Y_m through a proper block (Z.estimator) that produces the estimate Z_m . implementing the function $f(X_m, Y_m)$.

Signals.

Information is carried by signals. The latter can be of three different types, as shown in Fig.1.4. Analog signals are continuous in magnitude, since they can ideally assume all the values within their range. Digital signals are quantized in magnitude, since they can assume only a finite number of values. As a result, also the information carried by a digital signal is quantized. Analog and digital signals can be further divided into continuous time and discrete time signals. A continuous-time signal is valid for any instant of the interval of interest. Discrete time signals assume valid values only at instants that can be represented by a progression of integer numbers. Since, in all real cases, the time interval of interest is finite, then also the number of instants at which the signal is valid is also finite. Digital signals are always discrete-time, while analog signals can be either discrete or continuous time. For example, discrete time analog signals are present in switched capacitor circuits.

digital signals	discrete time
analog signals	discrete time
	continuous time

Fig.1.4

System Performance

The performance of a DAS is given by the “closeness” of the estimates ($X_m, Y_m, Z_m \dots$) with respect to the corresponding physical quantities ($X, Y, Z \dots$). More precisely, the following error can be defined:

$$x_e = X - X_m \tag{1.1}$$

This is equivalent to consider that a complete acquisition channel of a DAS (e.g. channel X) can be modeled as an ideal system (defined by the identity block I in Fig. 1.5), with the addition of the disturbance $-x_e$ at the input.

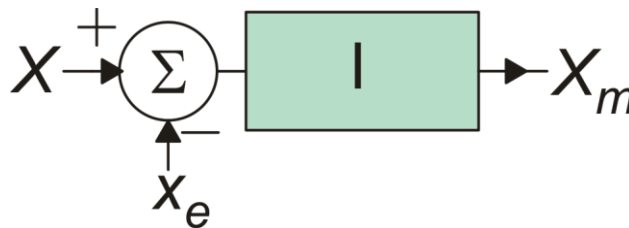

Fig. 1.5

In a system formed by the cascade of several blocks, the total error x_e is the sum of the contribution of all blocks. Fig. 1.6 shows the block diagram of the DAS, with the errors highlighted. Each block is modeled as an ideal (errorless) block with an adder that sums up an error term at the output. The numbers 0, 1, 2, 3, 4 identify the points where the signal is considered. The number 0 identifies the original quantity to be measured, the number 1 the quantity at the output of the sensor and so on. The

terms e_{x1} , e_{x2} , e_{x3} are error terms that are considered to be injected at positions 1, 2, 3, respectively. In order to calculate the contribution of a single error term to the overall error x_e (see fig. 1.5) it is necessary to define the sensitivity. If we consider the signal at the i -th position, the sensitivity from the input quantity to that position is given by:

$$k_{X0,i} = \frac{\partial V_{Xi}}{\partial X} \tag{1.2}$$

where V_{xi} is the signal at position i -th. The sensitivity can be considered as the small signal gain from the input position to the considered output position. It is possible to define the sensitivity from whichever position, not only from position 0. Examples of sensitivities are represented in Fig.1.6 by means of paths connecting the input to the output position.

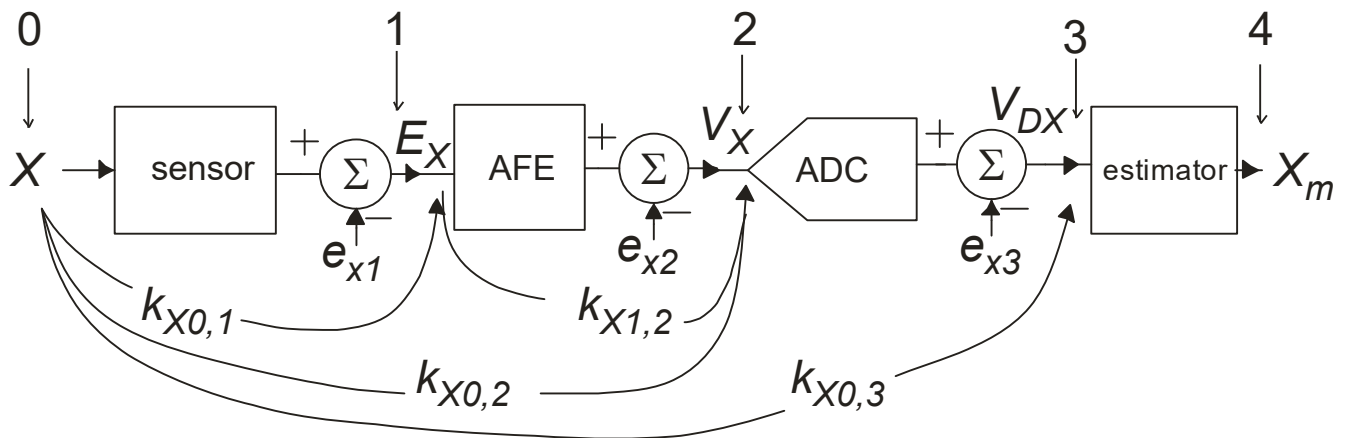

Fig. 1.6

Each error contribution can be referred to the input quantity through the corresponding sensitivity. Consider Fig. 1.7, where the i -th position is examined. We suppose that the error e_{xi} is summed up to the signal coming from previous blocks.

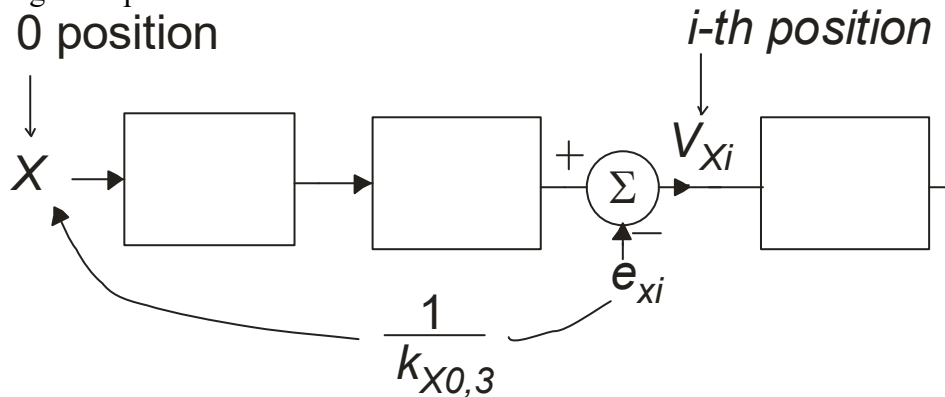

Fig.1.7

The corresponding input quantity, x_{ei} is given by:

$$x_{ei} = \frac{e_{xi}}{k_{X0,i}} \quad (1.3)$$

In order to calculate the total error it is necessary to sum up the input referred values of all error components that are injected into the read-out channel by the various blocks.

Note that, if the response of the system is non-linear (for example because of sensor non-linearity), the sensitivity is not constant over the input quantity interval. Therefore, if we consider an error source that is not dependent on the input signal (for example noise from an amplifier), this error will result in a larger input referred uncertainty in intervals of the input quantity where the sensitivity is smaller.

Error on dependent quantities.

We have seen that a dependent quantity is not directly measured but its value is calculated starting from the estimates of other quantities, which, on the contrary, are measured (independent quantities). It is important to calculate how the errors on the independent quantities affect the error on the dependent one. Considering, for example, $Z=f(X,Y)$ and suppose that the function f is implemented by the Z -estimator with infinite precision. Then the Z estimate will be $Z_m=f(X_m, Y_m)$. But:

$$Z_m = f(X_m, Y_m) = f(X - x_e, Y - y_e) \quad (1.4)$$

Using the first order Taylor approximation:

$$Z_m = f(X, Y) - \frac{\partial f}{\partial X} x_e - \frac{\partial f}{\partial Y} y_e = Z - \left(\frac{\partial Z}{\partial X} x_e + \frac{\partial Z}{\partial Y} y_e \right) \quad (1.5)$$

The error on Z , equal to $Z-Z_m$, is given by:

$$z_e = \left(\frac{\partial Z}{\partial X} x_e + \frac{\partial Z}{\partial Y} y_e \right) \quad (1.6)$$

This expression can be easily extended to the case of more than two independent variables.

Types of errors.

There are three types of errors that can be distinguished:

1. **Quasi static errors.** These errors can be considered to be constant during the whole observation period. The observation period is the time during which the system is monitored (from several seconds to several hours).
2. **Dynamic errors.** These are errors that exist only during transients and are due to the slowness of the system.
3. **Noise.** This term indicates all kind of unwanted time varying systems that are superimposed to the signal. It includes random noise, which is due to phenomena involving the charge carriers (electrons, holes and others) at the microscopic scale, as well as disturbances due to external sources, generally referred as interference.

Quasi static errors can be divided into the following categories:

-) Offset error
-) Gain error
-) Non linearity error.

The offset error is responsible for the fact that, when an input zero quantity is applied, the output is not equal to the conventional zero. More precisely, for a DAS, the input offset X_{i0} is the value of quantity X that produces a zero estimate ($X_m=0$).

The Gain error can be easily understood if we consider a linear readout system. If we takes into account position i -th in the readout chain, than, nominally:

$$V_{Xi-nom} = k_{X-nom} X \quad (\text{linear system}) \quad (1.7)$$

where k_{X-nom} is the gain of the system from the X to the i -th position in nominal conditions. Due to an error on the gain, we have that the actual gain is:

$$k_{X-real} = k_{X-nom} + k_{X-err}$$

where k_{X-err} is the gain error term. With this value we have:

$$V_{Xi-real} = (k_{X-nom} + k_{X-err}) X$$

Since we do not know the actual gain, we have to estimate the input quantity by using the nominal gain. Thus:

$$X_m = \frac{V_{Xi-real}}{k_{X-nom}} = X + \frac{k_{X-err}}{k_{X-nom}} X$$

Comparing this equation with Eqn.(1.1), we obtain that the input referred error due to the gain error is

$$x_{e-gain} = -\frac{k_{X-err}}{k_{X-nom}} X \quad (1.8)$$

We note that:

- (1) the error is proportional to the input quantity. Therefore, the error due to gain inaccuracy is not an additive term, since it depends on the input signal.
- (2) the error gain is a relative error, since the ratio k_{X-err}/k_{X-nom} appears in the input referred error contribution.

Methods for reducing the gain error:

In order to obtain precise gains (and thus small gain errors) it is important that the gain depends only on two types of contributions:

-) Ratios between quantities that have the same dimensions, relating to objects fabricated with the same technology. These kind of dimensionless ratios are affected only by matching errors, which can be reduced to less than 0.1%. In addition, temperature variations affect in the same way the two terms of the ratio, which, as a result, remains unchanged.

-) Precise quantities (not dimensionless). In nature, there are quantities that can be made very precise, such as the output frequency of a quartz oscillator.

Clearly, if the input and output quantity (X and V_{Xi} , respectively, in Eq.1.7), have not the same dimensions, the gain cannot involve only dimensionless ratios, but should include at least one non-dimensionless quantity, which, should be made as precise as possible.

In all cases where the above rules cannot be respected, the gain can be affected by large errors. For example, in integrated circuits, if a gain is proportional to the resistance of an on-chip resistor, gain errors more than 10 % can be expected. In these cases, it is necessary to individually trim each fabricated device.

Ratiometric systems.

In these systems, the gain is purposely made to be proportional to the power supply voltage V_{dd} . This seems an inaccurate approach, since the V_{dd} is generally provided by power voltage regulators that are not as precise as voltage references. This drawback is completely overcome if we combine the ratiometric readout channel with an ADC that uses V_{dd} as its reference voltage (see Fig 1.8).

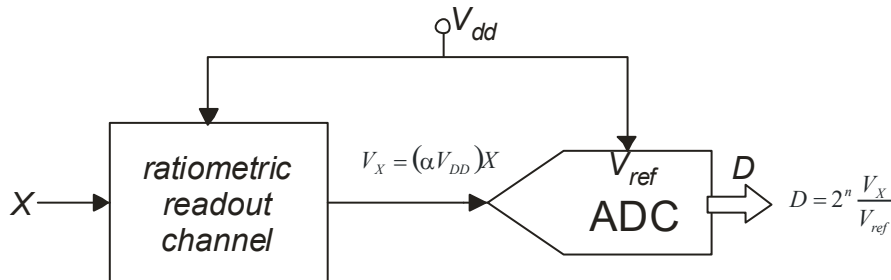

Fig. 1.8

The gain of the ratiometric system is given by αV_{dd} , where α is a constant. Many systems, such as Wheatstone bridges, used to read resistive sensors, are intrinsically ratiometric. The output code of the ADC is indicated with D , while n is the ADC resolution. Substituting the expression of V_X into the output code, we obtain a result that is independent of the V_{dd} value. In this way, it is possible to use V_{dd} as a voltage reference with no penalty in terms of accuracy. The advantage is that the need of a precise voltage reference (such as a band-gap circuit) is avoided.

Non linearity errors.

The errors derive from the use of an approximate law to model the sensor response. In the sketch of Fig. 1.9, we show the output voltage of a readout channel (V_X) as a function of the input quantity. The real sensor response is represented by the curve (actual curve). In order to obtain a precise estimate, the X estimator (see Fig. 1.3) should have a transfer characteristic equal to the inverse of the actual response. If a computational unit is not available, a possible solution is to use a linear approximation,

which can be easily implemented with very simple logical blocks. Clearly, this introduces an error which is shown in the figure by the difference between the actual value of the input quantity (X) and its estimate (X_m), obtained starting from the output voltage value V_{X^*} .

A non linearity error may still be present also when more precise approximations, such as polynomial or exponential functions are used (residual non linearity error). It should also be observed that the non-linearity of the response varies among the different samples of a particular system. These errors will remain even if the nominal curve used to interpret the sensor response is virtually exact.

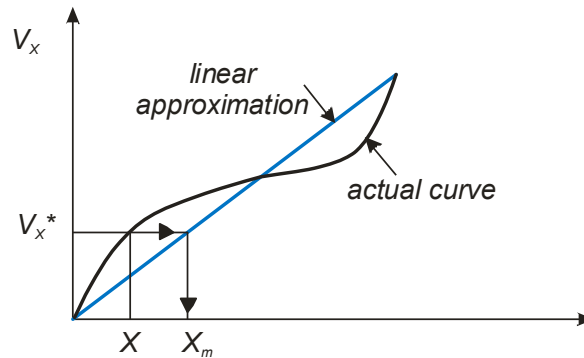

Fig. 1.9

Dynamic errors.

Fig. 1.10 (a) shows the response of a DAS to a step variation of the input quantity. The figure includes also (quasi)-static errors, which cause the response to start from and settle to a value which is different from the actual X value. Note that the X estimate does not reach the final value immediately and the estimate significantly differs from the final value during the transient period. During this transient time, the difference between the estimate and the actual X value can be much larger than the static error, so that the output of the DAS will be invalid during this time. An important parameter is the settling time, t_{set} , defined as the time necessary for the estimate X_m to get closer than a certain margin to the final value. In practice, after t_{set} , the difference from the final value stays within a given error band placed across the final value. A typical error magnitude used to define the settle time is $\pm 1\%$. For high precision systems, 0.1% or 0.01% settling time specifications are also common.

The reason of the system slowness is due to inertial elements, which, in the electronic domain, are mainly capacitances and, less frequently, inductances. An important contribution may also derive from the sensor, where non-electrical elements (mechanical and thermal masses, diffusion and adsorption phenomena) are likely to play an important role.

The response speed of a DAS can be expressed by two parameters:

-) Frequency bandwidth, B_S
-) Slew rate, s_r .

The bandwidth refers to the linear behavior of the system, which generally occurs when the input variations are small (e.g. small magnitude steps) or slow. The slew rate is the maximum value of the time derivative of X_m . For example, in the case of large steps, the derivatives is no more proportional to the step magnitude, but saturates to a maximum value s_r .

Therefore, the bandwidth affects the response to small signals while the slew rate refers to large signals. In most cases both parameters contribute to the settling time, since the system is in the slew-rate condition in the initial part of the transient and gets into linear operation in the last part. The analysis in these conditions is difficult and strongly depends on the system architecture. It is interesting to consider the value of the settling time when only one parameter dominates.

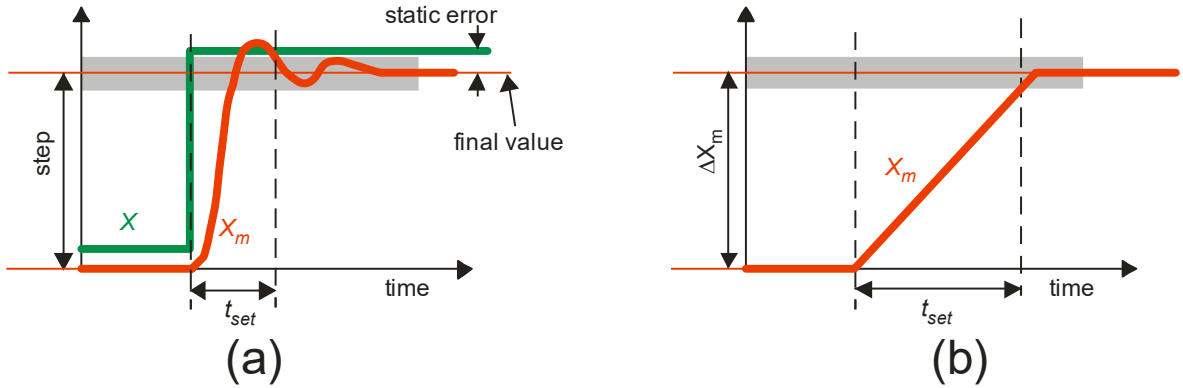

Fig.1.10

For linear responses, when B_s dominates, we have the approximate condition:

$$t_{set} \cong \frac{1}{B_s} \tag{1.9}$$

This expression is precise for the 1 % settling time of a system characterized by a second order low-pass Butterworth response. In the case of first order low pass response, the t_{set} given by the previous equation should be multiplied by 0.73. The settling given by (1.9) can be widely exceeded when the transfer function is characterized by pairs of complex conjugate poles with a high quality factor (Q). In this case, poorly dampened oscillations are present on the step response and the settling time is adversely affected.

If the slew rate dominates, as shown in fig. 1.1(b), we simply have:

$$t_{set} \cong \frac{0.99 \cdot \Delta X_m}{s_r} \cong \frac{\Delta X_m}{s_r} \cong \frac{\Delta X}{s_r} \tag{1.10}$$

The important difference here is that the settling time depends on the amplitude of the input step (ΔX)

Noise.

In electronics, the term noise indicates unwanted signals that contaminate the desired signal. This definition includes also capacitive or magnetic interference from equipments placed in the vicinity of the circuit that we are examining or disturbances induced by incoming electromagnetic waves. From now on, unless explicitly stated, we will use the term noise only to indicate random signals generated by microscopic phenomena occurring inside the same blocks and devices that form the DAS, including the sensor.

If we consider a constant value for the input quantity, noise produces random oscillations across the theoretical output constant value. Noise affects the resolution of the system, which is the minimum difference between two values of the input quantity that can be distinguished. Fig. 1.11 (a) shows a

sketch of the estimates X_m produced by the DAS as a function of time for two different values of the input quantity X . The output estimates varies around the mean value (indicated by the red line) for the effect of noise. The interval of possible values that can be assumed by the signal around the mean value is called “noise-band”. The amplitude of the noise-band corresponds to the peak-to-peak magnitude of the noise (x_{np-p}). At this point, it should be observed that most cases of random noise are characterized by distributions of values theoretically spread over an infinite interval (see for example Gaussian noise). In practice, it is possible to consider a finite interval where most values fall, or, more precisely, a given percentage of values fall. For a Gaussian distribution, which fits most practical cases with reasonable precision, probabilities are shown in Table 1.1, where σ indicates the standard deviation.

Interval	Total interval width (x_{np-p})	Probability	1 – probability
$\pm\sigma$	2σ	0.683 (68.3 %)	0.317
$\pm 2\sigma$	4σ	0.954 (95.4 %)	0.046
$\pm 3\sigma$	6σ	0.997 (99.7 %)	0.003
$\pm 4\sigma$	8σ	0.999936 (99.9936 %)	6.4×10^{-5}

Table 1.1

In the following part of this document, unless differently specified, we will assume a noise interval amplitude of 4σ . Considering Table 1.1, this means that the total signal (ideal signal + noise) will spend 95 % of time within the noise band. Equivalently, this means that, if we sample the output noise, more than 95 % of samples will fall inside the error band.

If we consider two different values of the input quantity, as in Fig.1.11(a), separated by the difference ΔX , and we suppose that there are not gain and non-linearity errors, the average value of the output estimates are separated just by ΔX . The noise-bands are shifted also by ΔX . The figure shows a situation where the difference ΔX is so small that the noise bands corresponding to the two values of the input quantity are partially overlapped. The intersection of the two bands includes values of the output, which are compatible with both values of the input quantity; therefore, at the instants when the signal is inside the intersection region, it is not possible to decide which one of the two input values is actually present at the input.

In order to be able to distinguish between two values of the input quantity, there should be no overlap between the corresponding noise bands. The smaller difference that can be distinguished, i.e the resolution, occurs when the two noise bands are adjacent, as shown in fig.1.11(b). Since, in this case, the two values of the estimate are separated by two half noise-bands, the resolution is simply given by the amplitude of the noise-band, i.e. by x_{np-p} . Considering again how we have defined the error band, if we try to use the system to distinguish between two quantities that differs by just the resolution, then the answer will be correct for 95.4 % of all cases. For system requiring a lower error probability, different definition of the error band should be adopted (e.g. 6σ instead of 4σ). Clearly, with this different definition, the resolution of the system will turn out to be worse (larger minimum ΔX).

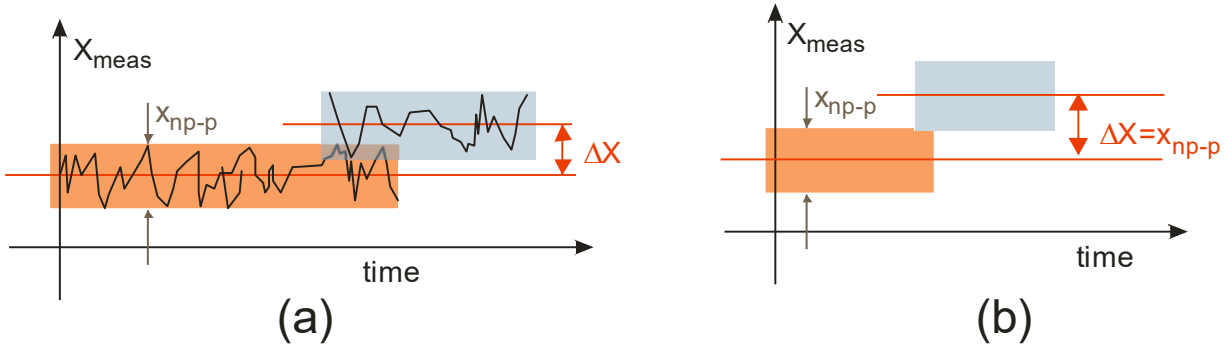

Fig. 1.11

Total accuracy of the DAS.

In metrology, accuracy represents the closeness of the result of measurement with respect to the actual value. Strictly speaking, the accuracy is not a numerical value, but just a “quality”, which includes several quantitative parameters used to define the property of the error (presence of systematic components, repeatability and reproducibility, variance of random errors, etc.). In the practical use, the accuracy is the difference between the measured and actual values of the input quantity. Generally, accuracy does not include noise contributions; since they are zero-mean random signal that can be arbitrarily reduced by averaging large sets of measurements. In the case of a DAS, averaging is equivalent to apply a low-pass filter to the signal stream, slowing down the system. When we consider the errors on the measurements, we should assume that the bandwidth has already been reduced to the minimum value needed to guarantee the required system response speed (e.g. settling time). Therefore, each sample coming out from the measurement system has to be regarded as a significant sample and no more operations are allowed. Consequently, we will include also the noise contribution into the definition of total accuracy, since it has to be intended as the closeness of each single sample of the output signal (estimates stream, X_m), with respect to the real value of the input quantity. Therefore, the accuracy will be given by the sum of the maximum static error (absolute value) and the maximum noise error (absolute value). As far as noise is considered, the maximum absolute noise value is the peak value, i.e. half the peak-to peak value.

Additive errors and detection limit.

In many practical cases, noise and offset do not depend on the input signal, thus they can be considered as additive errors. This property is particularly important for defining the detection limit of the system, i.e. the capability of detecting very small values of the input quantity. Examples that show how this parameter can be important are represented by the detectors of harmful gases, which, for certain substances such as nitrogen oxides, should be able to raise a reliable alarm for concentrations as low as a few part per billion. Other examples are given by flow sensors designed to detect very small flow rates in pipes, in order to detect fluid leaks.

In order to find out which parameters really affect the detection limit, we have to consider what happens when a zero input quantity is applied to the system. From Eq.(1.8) we note that for $X=0$ there cannot be a gain error. In addition, non-linearity errors, occurring at large values of the input signal can be neglected. Therefore, the only error sources that affect the measurement are offset and noise, i.e. the additive errors. Fig.1.12 (a) shows the output signal band, when a zero input signal is applied. Considering Eq. (1.1), the input offset error (X_{io}) shifts the measurement result by $-X_{io}$. Noise adds up

random oscillations around this value. All measurements values fall within the noise band, as shown in the figure.

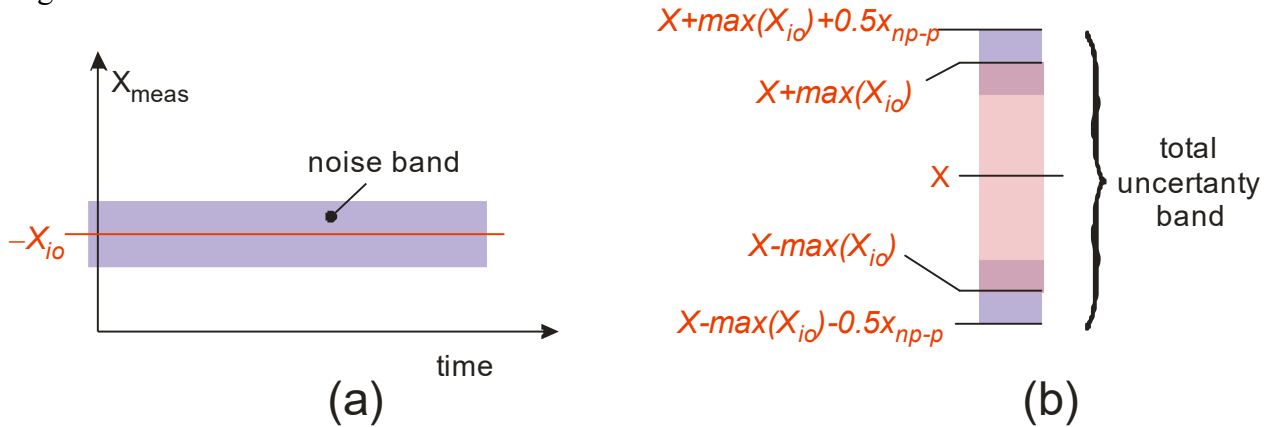

Fig.1.12

The situation depicted in Fig. 1.12 (a) refers to a single device, where we can consider the offset as a known quantity. In many cases the offset of a given system cannot be measured, or, at least, not with sufficient precision. It should also be considered that the offset varies for the effect of temperature and device ageing. As a result, in many cases, we have to consider also the offset as an unknown random quantity to be represented by its statistical properties. The offset is generally given in terms of maximum offset, $\max(X_{io})$, which is actually the maximum of the absolute value of the offset. The possible offset values are generally also symmetrical with respect to zero, so that the range of possible offset value will be $[-\max(X_{io}), \max(X_{io})]$. Since the noise band is placed across the offset values, the total range of values that the measurement system may produce when $X=0$ is shown in Fig. 1.12(b). Thus, the minimum value of the X_m measurement that can be reliably referred to a non-zero input quantity is given by (absolute value):

$$\min(|X_m| \Rightarrow X \neq 0) = \max(X_{io}) + \frac{1}{2}x_{np-p} \tag{1.11}$$

Note that Eq.(1.1) does not give the minimum detectable quantity, which, instead should be calculated considering Fig.1.13, where the interval of possible measured values X_m is given as a function of the input quantity X , in the case that gain and non-linearity errors have been already corrected. The line $X_m=X$ represents the ideal case, where no noise and no offset are present. In the real case, the measurements fall in the band indicated in the figure.

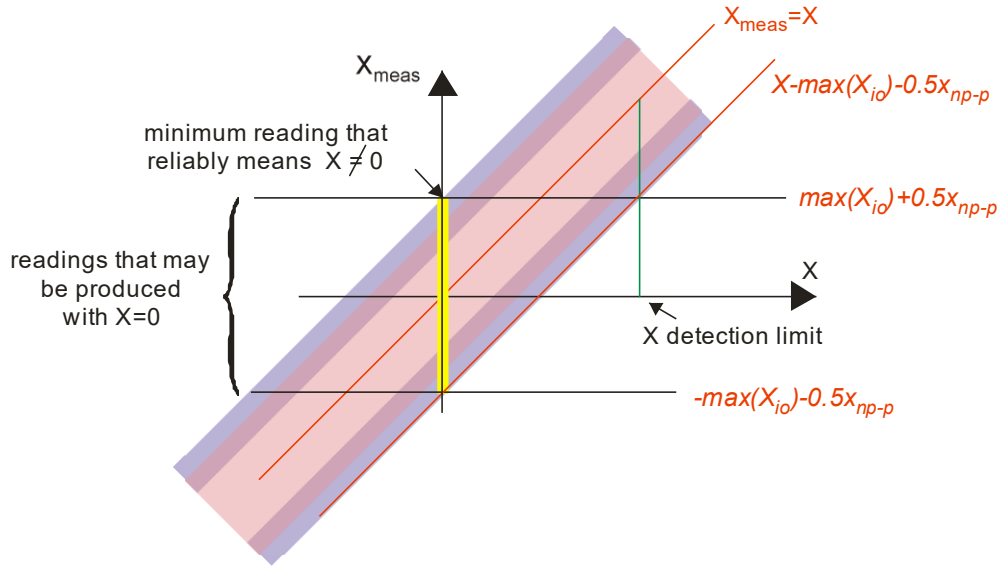

Fig.1.13

For an input quantity to be reliably recognized as non zero, the interval of output values should have no overlap with the interval of possible values produced when $X=0$. Considering Fig.1.13, it can be easily shown that the absolute value of the detection limit should be at least as large as the complete error band, i.e:

$$\text{detection limit} \equiv 2 \max(X_{io}) + x_{np-p} \tag{1.12}$$

Signal limits and dynamic range.

The input quantity values that can be applied to a DAS should stay within a lower limit (X_{min}) and an upper limit (X_{max}) in order for the system performance to be maintained. The limits are generally due to excessive non-linearity occurring when the signal magnitude becomes too large. In particular cases, the limits can be due to the onset of phenomena that can be destructive for the system.

The full scale range of a system, indicated with ΔX_{FS} is given by the difference:

$$\Delta X_{FS} \equiv X_{max} - X_{min} \tag{1.13}$$

Note that X_{min} is not necessarily a small quantity, since it may be a negative value with a large absolute value. A typical example is given by symmetrical input ranges, where $X_{min} = -X_{max}$.

The full scale range is a measure of the real extension of the interval across which the input quantity can vary.

An important parameter that characterizes the system performance is the dynamic range (DR). This is a dimensionless ratio given by:

$$DR \equiv \frac{\Delta X_{FS}}{\delta X} \tag{1.14}$$

where δX is generically the smallest quantity that can be detected. Note that the definition of the DR varies depending on the way we define δX . In systems where the signal bandwidth does not extend

down to DC, the offset is not relevant and the minimum detectable quantity is affected only by noise, so that δX coincides with the system resolution. This is also the case of systems where offset compensation is feasible and reliable. In the case that the signal bandwidth includes DC and the offset cannot be effectively cancelled δX should be considered to be equal to the detection limit calculated in Eq.(1.12). In common practice the DR is calculated considering only the noise contributions, so that δX is the resolution. An interesting interpretation of the DR can be found when we consider that δX coincides with the resolution. If we consider X_{min} , then the closest quantity that can be distinguished from X_{min} is $X_{min}+\delta X$. Then, we have to add another increment δX to reach the next value that can be distinguished from $X_{min}+\delta X$. Proceeding in this way, we reach X_{max} after $(X_{max}-X_{min})/\delta X$ steps, i.e. after a number of steps equal to DR. Then the DR can be considered as the maximum number of different levels of the input quantity that can be distinguished by the DAS. This situation is similar (but not identical) to what happens in an ADC, which can distinguish only 2^n levels, where n is the converter resolution (defined as number of bits). For this reason the DR is sometimes expressed in terms of number of bits and, on the other hand, it should be observed that a possible way to express the resolution of an ADC is to give the DR. Normally the DR is expressed in decibels.

It is important to observe that the DR of the whole system depends on the DR of the blocks that compose it. The knowledge of the DRs of the single blocks is not sufficient to calculate the overall DR. In fact, the overall DR depends also on the way the output range of each block matches the input range of the following block.

In order to understand this, let us consider Fig. 1.14, where connection between block A and next block B is shown. The signal at the output of A, which coincides with the signal at the input of block B, is indicated with V . We focus on the input range of block B, limited between V_{min} and V_{max} . We consider that these limits are due only to block B, thus stricter range boundaries can arise from the blocks that follow B. Then we have indicated with X_{min} and X_{max} the limits on the input quantity that derive from all blocks of the DAS (including also block B). When X varies from X_{min} to X_{max} , voltage V swings from $V(X_{min})$ and $V(X_{max})$. Figure 1.14 represents also the levels, into which the input range of B is ideally divided. As we have shown earlier, the levels derive from the resolution (i.e. noise) of block B. In the case depicted in the figure, when X swings across its input range, voltage V explores only a fraction of the input range of block B. Then, the actual number of levels that are involved is smaller than all those that can be provided by block B. This is a case that can potentially result in dynamic range degradation, especially if the resolution of B is relatively low. In order to exploit all the levels of block B, an amplifier could be placed between A and B, provided that this additional block does not introduce further range limitation or significant noise.

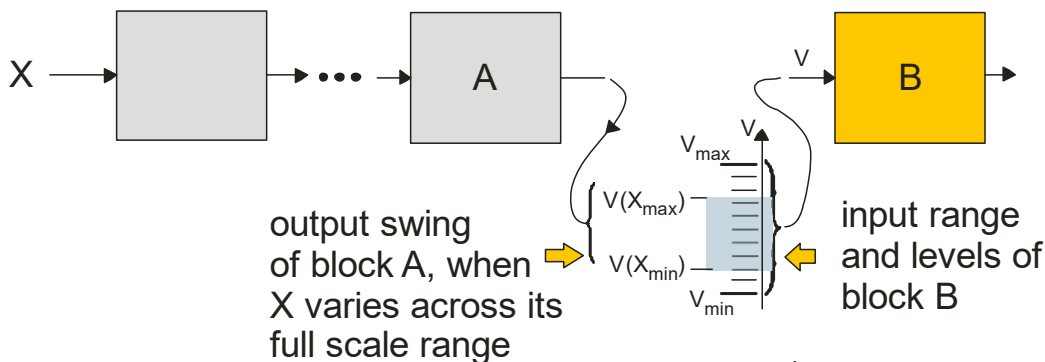

Fig.1.14

If the system is linear, it is possible to demonstrate that the DR of the whole system cannot be larger than the DR of each individual block. Let us consider block B, and define its dynamic range as:

$$DR_B \equiv \frac{V_{\max} - V_{\min}}{\delta V} \quad (1.15)$$

where δV is the maximum error introduced by B (noise, or noise + offset) referred to the input of block B. Clearly, since the system is linear, we can write: $V = k_V X$, where k_V is a constant corresponding to the sensitivity of V vs. X . For simplicity, we will assume that k_V is positive; this is not a restriction since the procedure can be easily repeated for $k_V < 0$. The error δV , referred to the input quantity X will be given by $\delta V/k_V$.

Since the error introduced by block B is only one component of the total error on X , we can write:

$$\frac{\delta V}{k_V} \leq \delta X \Rightarrow \delta V \leq k_V \delta X \quad (1.16)$$

Let us now consider the limits of the range. Clearly, for all values belonging to the X overall range (interval $[X_{\min}$ and $X_{\max}]$) block B should operate correctly, then V should be within the input range of block B. Therefore:

$$\left. \begin{array}{l} k_V X_{\min} \geq V_{\min} \\ k_V X_{\max} \leq V_{\max} \end{array} \right\} \Rightarrow \left. \begin{array}{l} -k_V X_{\min} \leq -V_{\min} \\ k_V X_{\max} \leq V_{\max} \end{array} \right\} \Rightarrow k_V (X_{\max} - X_{\min}) \leq V_{\max} - V_{\min} \quad (1.17)$$

Then we can operate the following substitution in 1.15:

$$\begin{cases} k_V \delta X \rightarrow \delta V \\ k_V (X_{\max} - X_{\min}) \rightarrow V_{\max} - V_{\min} \end{cases}$$

Considering Eq.(1.16) and (1.17), this increases the denominator and decreases the numerator of the DR_B expression, defined in Eq.(1.15). Then:

$$DR_B = \frac{V_{\max} - V_{\min}}{\delta V} \geq \frac{k_V (X_{\max} - X_{\min})}{k_V \delta X} = \frac{(X_{\max} - X_{\min})}{\delta X} = DR \quad (1.18)$$

where DR indicates the overall dynamic range of the system. This means that that DR of all blocks is constrained to be larger than or, at least equal to the target DR of the whole system.