

1 Three network analysis methods useful for the design of analog circuits.

1.1 Effects of device parameter change on the network DC solution

Device parameters are generally different from the nominal values, due to process spread, temperature, variations and ageing. It is important to estimate the effect of parameter changes on the network response and performance. Here we will focus on the effect of parameter changes on the DC solution of a non-linear network. For a more general theory, see Ref.[1]. Typical application of this study is the estimation of the offset and offset drift of an amplifier. Other useful applications are in the world of sensors, where it is very common that the quantity to be sensed is detected through the variation of a device parameters (e.g. a resistance variation in resistive sensors). It should be pointed out that this study requires that the parameter variations are small. We will refer to the case shown in Fig. Error! Use the Home tab to apply Titolo 1 to the text that you want to appear here..1, where we are considering the effect of changes in the electrical parameter of a non-linear two-port network (Q) connected to a non linear sub-network (N).

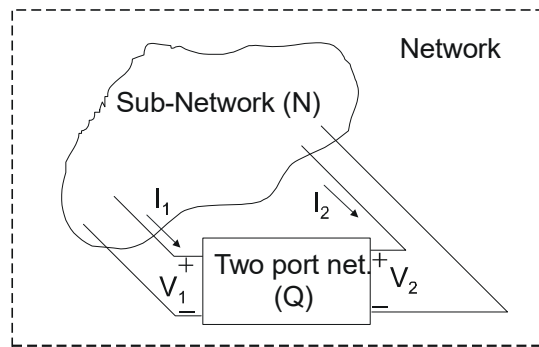

Fig. Error! Use the Home tab to apply Titolo 1 to the text that you want to appear here..1 Extraction of a two-port network (Q) from the original network.

The solution complete network is determined by the following equation sets

$$Q: \begin{cases} I_1 = f_1(V_1, V_2, P) \\ I_2 = f_2(V_1, V_2, P) \end{cases} \quad N: \begin{cases} I_1 = g_1(V_1, V_2) \\ I_2 = g_2(V_1, V_2) \end{cases} \quad (1.1)$$

where the sets Q and N are related to the two port network and sub-network, respectively. Functions f and g are generally non-linear. Furthermore, we have considered that the behavior of Q is affected by a parameter indicated with P . Generalization to a larger number of parameters is straightforward. We will

try to understand what happens to the network solution when parameter P changes from P_0 to $P_0 + \Delta P$. We will suppose that ΔP is small enough that, when P changes from P_0 to $P_0 + \Delta P$ the voltage and current variations induced in the network are so small that a linearization of both Q and N equation sets is possible. In other words, we can use the small signal equivalent circuits to study the effect of ΔP .

Then we can write:

$$Q: \begin{cases} i_1 = \frac{\partial f_1}{\partial V_1} v_1 + \frac{\partial f_1}{\partial V_2} v_2 + \frac{\partial f_1}{\partial P} \Delta P \\ i_2 = \frac{\partial f_2}{\partial V_1} v_1 + \frac{\partial f_2}{\partial V_2} v_2 + \frac{\partial f_2}{\partial P} \Delta P \end{cases} \quad N: \begin{cases} i_1 = \frac{\partial g_1}{\partial V_1} v_1 + \frac{\partial g_1}{\partial V_2} v_2 \\ i_2 = \frac{\partial g_2}{\partial V_1} v_1 + \frac{\partial g_2}{\partial V_2} v_2 \end{cases} \quad (1.2)$$

where, as customary, lowercase symbols (i.e. i_l, v_l etc.) indicates small signal quantities. Since ΔP is a known quantity, the linear equation set has four unknowns and, except for degenerate cases, since we have also four equations, there is only a single solution. Eqns. (1.2) show that the effect of the parameter variation is that of adding constant terms that, in the Y parameters schematization of the two port network, are constant currents. In different models of the two port network, such as z or h (hybrid) parameters, the constant terms can be represented either as currents or voltages.

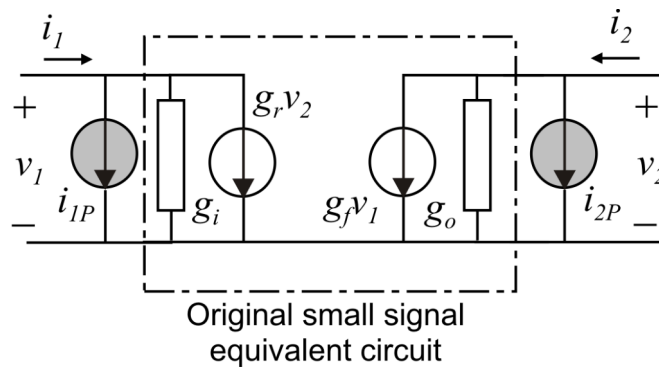

Fig. Error! Use the Home tab to apply Titolo 1 to the text that you want to appear here..2 Small signal equivalent circuit of the two-port network (dc y-parameters)

The effect, for the Y parameter schematization, is shown in Fig. Error! Use the Home tab to apply Titolo 1 to the text that you want to appear here..2, where two independent current sources i_{1p} and i_{2p} are added to the original small signal equivalent circuit. Considering Eqns. (1.2), the value of the current sources is:

$$i_{1P} = \frac{\partial f_1}{\partial P} \Delta P \quad i_{2P} = \frac{\partial f_2}{\partial P} \Delta P \tag{1.3}$$

where the derivatives are calculated at the rest point.

Example 1: ideal resistor.

Let us consider a resistor of value R . Suppose that the resistor changes from its nominal value (R) to $R+\Delta R$. Let us calculate the effect on the DC solution of the rest of the network.

The resistor can be considered a reduced case of two-port network, with $f_1=V_1/R$ and $f_2=0$, represented in Fig. Error! Use the Home tab to apply Titolo 1 to the text that you want to appear here..3 (left).

The equivalent Y parameters small signal circuit of the ideal resistor is that of Fig. Error! Use the Home tab to apply Titolo 1 to the text that you want to appear here..2, where only the conductance $g_i=1/R$ and the current i_{1P} are present. From Eqns. (1.3) we obtain:

$$i_{1P} = \frac{\partial(V_1/R)}{\partial R} \Delta R = -\frac{V_1}{R^2} \Delta R \tag{1.4}$$

Therefore, in order to obtain the variations induced on the whole network by the resistance variation (ΔR), we can add a current i_{1P} in parallel to resistor R and use for the subnet its small signal equivalent circuit (Fig. Error! Use the Home tab to apply Titolo 1 to the text that you want to appear here..3, middle). Alternatively, it is possible to obtain a Thevenin equivalent of the R/i_{1P} parallel, where the Thevenin voltage is $-i_{1P} \cdot R = \Delta R V_1/R = I \Delta R$, where I is the rest point current flowing through R (Fig. Error! Use the Home tab to apply Titolo 1 to the text that you want to appear here..3, right).

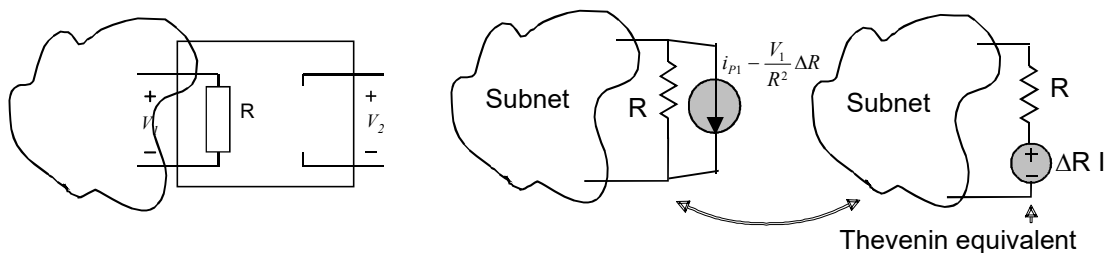

Fig. Error! Use the Home tab to apply Titolo 1 to the text that you want to appear here..3 Application of the method to a two-port network consisting of a single resistor

Example 2: MOSFET.

In this example, we are interested in calculating the effects of variations of MOSFET parameters on the DC solution of the network where the MOSFET is included. Using the square law approximation of the MOSFET drain current in saturation region and neglecting the effect of the V_{DS} we have the following analytical representation of the MOSFET as a non-linear two-port network:

$$MOSFET : \begin{cases} I_1 = f_1(V_{GS}, V_{DS}) = I_G = 0 \\ I_2 = f_2(V_{GS}, V_{DS}) = I_D = \frac{\beta}{2}(V_{GS} - V_t)^2 \end{cases} \quad (1.5)$$

As a consequence of variation of both β and V_t (parameters) we obtain that the effects on the network can be calculated using small signal circuits for both the MOSFET and the rest of the network and adding a current in parallel to port 2 (Drain-Source) equal to:

$$i_{2p} \equiv \Delta I_D = \frac{\partial I_D}{\partial \beta} \Delta \beta + \frac{\partial I_D}{\partial V_t} \Delta V_t = \frac{1}{2}(V_{GS} - V_t)^2 \Delta \beta - \beta(V_{GS} - V_t) \Delta V_t \quad (1.6)$$

By simple transformations, it is possible to obtain the compact formula:

$$\Delta I_D = I_D \left[\frac{\Delta \beta}{\beta} - \frac{2\Delta V_t}{(V_{GS} - V_t)} \right] \quad (1.7)$$

where I_D is the quiescent drain current of the nominal circuit.

Example 3: Matched devices.

Equations (1.4) and (1.7) give the value of the current sources to be added to a resistor and a MOSFET, respectively, in order to take into account the effects produced by parameter variations. The latter may have different origins, for example temperature variations or process spread. Parameter variations can be very large when a single device is considered. In the case of a MOSFET, the relative variation of the parameter β can be as large as $\pm 20\%$ of the nominal value while the threshold voltage V_t may vary of up to ± 100 mV. Clearly, the effects on the DC solution can be very large, resulting, for example, on very large amplifier offset voltages. In order to prevent this to occur, a proper design should be based on matched devices. For the sake of simplicity, we will consider here that matched devices satisfy the following conditions:

1. the two device are nominally identical;
2. the bias conditions (quiescent currents and voltages) are identical
3. the transfer functions that tie the quantity of the interest for the circuit (for example the output voltage of an amplifier) to the parametric currents of the two devices (i_{p1} and i_{p2}) are opposite.

For example, if the two matched devices are MOSFET they should be nominally identical and be biased with same nominal V_{GS} , V_{DS} and V_{BS}). The important characteristics of matched devices is the fact that their parameter variations are very similar.

Let us indicate a generic parameter (R , β , V_i in the two previous examples) with P , and use the following conventions:

- P_N =nominal value of matched devices 1 and 2
- P_1 ; P_2 : real value of parameter P for device 1 and 2, respectively.

Then:

$$\Delta P_2 - \Delta P_1 = (P_2 - P_N) - (P_1 - P_N) = P_2 - P_1 \equiv \Delta P_{1,2} \tag{1.8}$$

This obvious expression shows that the difference between the parameter variations ΔP_2 and ΔP_1 of two devices that share the same nominal value (P_N) is equal to the parameter difference between the two devices ($\Delta P_{1,2}$). In matched devices, although ΔP_1 and ΔP_2 can be singularly large, the difference $\Delta P_{1,2}$ (commonly indicated with “parameter mismatch”, or “matching error”) is generally much smaller (of the order of 1% for many quantity of interest). Due to the third condition of matched devices, the two parametric currents ΔI_{D1} and ΔI_{D2} produce effects on the quantity of interest through two opposite transfer functions, which have indicated with $-F$ and F , respectively, in Fig. **Error! Use the Home tab to apply Titolo 1 to the text that you want to appear here..4** In the example of Fig. **Error! Use the Home tab to apply Titolo 1 to the text that you want to appear here..4**, the quantity of interest is V_{out} .

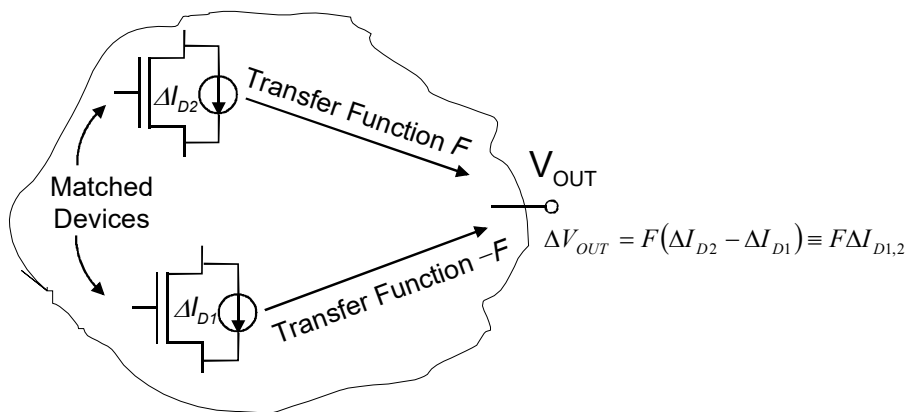

Fig. **Error! Use the Home tab to apply Titolo 1 to the text that you want to appear here..4**. Graphical representation of a matched pair

The variation produced by the combination of parameter variations of both matched devices is then given by:

$$\Delta V_{out} = F(\Delta I_{D2} - \Delta I_{D1}) \equiv \Delta I_{D1,2} \quad (1.9)$$

Using (1.8) and (1.9), we easily find:

$$\Delta I_{D1,2} = I_D \left(\frac{\Delta \beta_{1,2}}{\beta} - \frac{2\Delta V_{t1,2}}{(V_{GS} - V_t)} \right) \quad (1.10)$$

where I_D and $V_{GS} - V_t$ refer to the nominal solution of the network, while the following definitions have been used:

$$\begin{aligned} \Delta \beta_{1,2} &= \beta_2 - \beta_1 \\ \Delta V_{t1,2} &= V_{t2} - V_{t1} \end{aligned} \quad (1.11)$$

As we have seen, the difference between the parameters of two matched devices (i.e., the matching error) is much smaller than the individual parameter variations with respect to the nominal value. Then, on average, the following relationships apply:

$$\begin{aligned} |\Delta \beta_{1,2}| &\ll |\Delta \beta_1|, |\Delta \beta_2| \\ |\Delta V_{t1,2}| &\ll |\Delta V_{t2}|, |\Delta V_{t1}| \end{aligned} \quad (1.12)$$

Considering (1.9) and (1.10), which include only matching error, we can easily understand that the simultaneous effect on the output voltage of two matched devices is much smaller than the effect of parameter variations of the individual devices. Then, in a good design, all critical devices (i.e. those devices whose parameter variations has large effects on the output voltage) should appear in the circuit as matched pair, instead as single devices. In a differential amplifier, this is the case of the input devices (source coupled differential pair) and their load devices.

1.2 Generalized Norton equivalent circuit obtained by probing a nonlinear network by means of an ideal voltage source.

Consider a network that may include non-linear elements and DC sources (currents and voltages). For example, such a network may represent the rest point for an amplifier, or a situation of the same amplifier in presence of a constant DC input. Let us consider two nodes of the network, indicated with H and K in Fig. Error! Use the Home tab to apply Titolo 1 to the text that you want to appear here..5. For simplicity, we will indicate these nodes as “output nodes” of the network. We probe the network by connecting an ideal voltage source (V) across H and K, as symbolically indicated in Fig. Error! Use the Home tab to apply Titolo 1 to the text that you want to appear here..5.

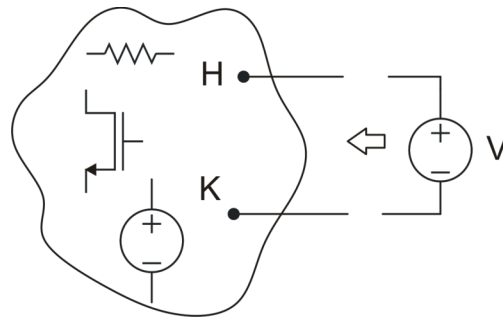

Fig. Error! Use the Home tab to apply Titolo 1 to the text that you want to appear here..5. Probing a non-linear network by connecting a test voltage source (V) across a pair of nodes.

As a first test we set voltage V to a constant value V_B and we measure the current I_{SC} (short circuit current) flowing from the source to the network, as shown in Fig. Error! Use the Home tab to apply Titolo 1 to the text that you want to appear here..6 (a). Note that voltage V_B can be substantially different from the voltage present across H and K before the application of the source V . Clearly, in the particular case that V_B is equal to the rest point voltage, the current I_{SC} is zero. If V_B is different from the rest point voltage, a non-zero current I_{SC} would probably flow as a reaction for forcing the voltage V_{HK} to assume the value V_B .

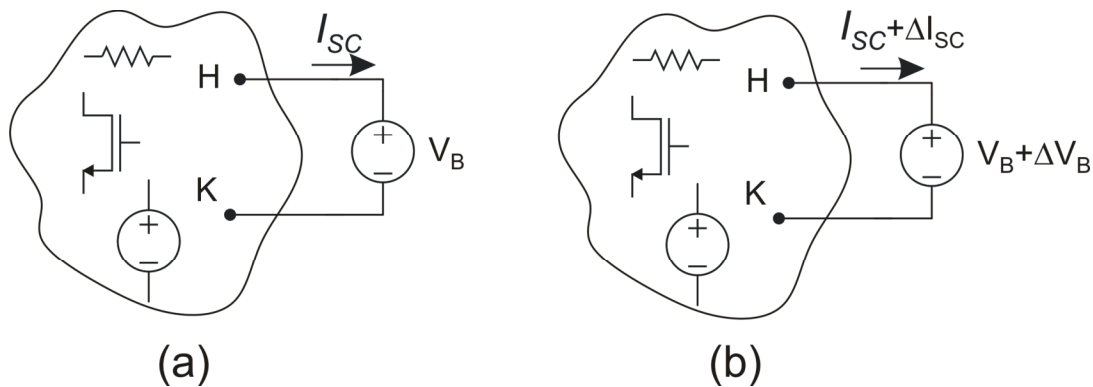

Fig. Error! Use the Home tab to apply Titolo 1 to the text that you want to appear here..6. (a) Short circuit current definition; (b) voltage increment used to evaluate the output resistance.

After that, we modify V_B by applying an increment ΔV_B , as shown in Fig. Error! Use the Home tab to apply Titolo 1 to the text that you want to appear here..6(b), producing an increment of the current I_{SC} , indicated with ΔI_{SC} . If, for a certain interval of voltages of the source V , the relationship between ΔI_{SC} and ΔV_B is linear, then the network seen from nodes K and H can be modeled by the circuit in Fig. Error! Use the Home tab to apply Titolo 1 to the text that you want to appear here..7, where R_{out} is equal to:

$$R_{out} = \frac{\Delta V_B}{-\Delta I_{SC}} \tag{1.13}$$

Note the output resistance R_{out} coincides with the differential (i.e. small signal) resistance seen by the source V , around the rest point of the network obtained by connecting the voltage source $V=V_B$, as in Fig. Error! Use the Home tab to apply Titolo 1 to the text that you want to appear here..6(a). The minus sign in front of the term ΔI_{SC} in (1), derives from the conventional sign of current I_{SC} in Figs. Error! Use the Home tab to apply Titolo 1 to the text that you want to appear here..6(a) and Error! Use the Home tab to apply Titolo 1 to the text that you want to appear here..6(b).

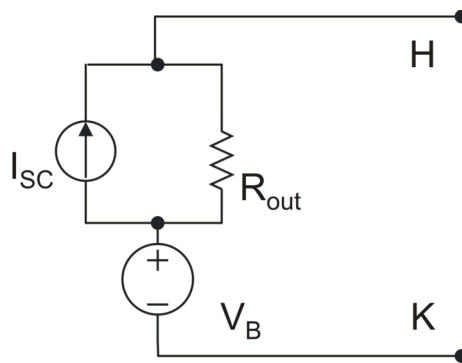

Fig. Error! Use the Home tab to apply Titolo 1 to the text that you want to appear here..7. Generalized Norton equivalent of the network.

This point can be easily demonstrated by repeating the tests of Fig. Error! Use the Home tab to apply Titolo 1 to the text that you want to appear here..6(a) and Error! Use the Home tab to apply Titolo 1 to the text that you want to appear here..6(b) using the equivalent circuit of Fig. Error! Use the Home tab to apply Titolo 1 to the text that you want to appear here..7. In the first case, the voltage across R_{out} is zero so that no current flows through the resistor. Then the current flowing from the source is just I_{SC} . In the case of the second test, depicted in Fig. Error! Use the Home tab to apply Titolo 1 to the text that you want to appear here..6(b), the increment ΔV_B is applied across R_{out} , so that the total current is:

$$I = I_{SC} + \frac{V_B - (V_B + \Delta V_B)}{R_{out}} = I_{SC} - \Delta V_B \left(\frac{-\Delta I_{SC}}{\Delta V_B} \right) = I_{SC} + \Delta I_{SC} \tag{1.14}$$

Thus, the equivalence has been demonstrated to be valid for all voltages V_{HK} for which the differential resistance seen across terminal H,K (R_{out}) is a constant.

Removing the voltage source (terminals H-K open), the output voltage $V_H - V_K$ becomes:

$$V_{HK} = V_B + R_{out} I_{SC} \tag{1.15}$$

If the V_{HK} value found in this way is within the range of output voltages where R_{out} is constant, then this is an acceptable approximation of the real solution. Otherwise, the estimate obtained with (1.15) can still be useful to understand if the output voltage exceeds the lower or higher bound of the linearity range. In the case of an amplifier, this means that the output is saturated (high or low). Furthermore, if the short circuit current can be controlled by some design parameters, it is possible to use (1.15) to calculate the I_{SC} value required to obtain a certain output voltage that belongs to the output linearity range.

1.3 Application of the cut-insertion theorem to the design of closed loop, op-amp based networks.

Ideal block diagrams of feedback systems.

Figure Error! Use the Home tab to apply Titolo 1 to the text that you want to appear here..8 shows a typical block diagram used in control theory to model feedback systems. All blocks are ideal and unidirectional. The names inside the block symbols (e.g. “A”) identifies both the block name and transfer function. By simple calculations:

$$\frac{V_{OUT}}{V_S} = -\frac{\alpha \beta A}{\beta \beta A - 1} \tag{1.16}$$

When $|\beta A|$ tends to infinity, V_{out}/V_s tends to $-\alpha/\beta$. In order to obtain a reliable overall transfer function, individual transfer functions α and β must be reliable, i.e. they should be designed to have as small as possible temperature coefficients, reduced dependence on process variations and high time stability. On the other hand, block A (amplifier) should exhibit high gain (to guarantee an high $|\beta A|$ value, since generally $|\beta| \leq 1$), and provide the required power to drive the load.

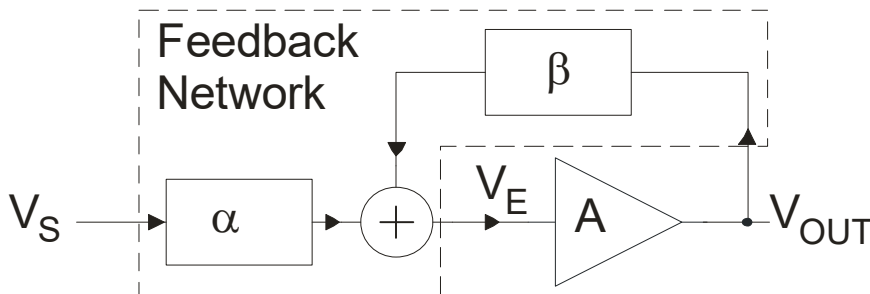

Fig. **Error! Use the Home tab to apply Titolo 1 to the text that you want to appear here..8**. Typical block diagram used in control theory

Equation (1.16) can be re-written as:

$$A_L \equiv \frac{V_{OUT}}{V_S} = -\frac{\alpha}{\beta} \left(1 + \frac{1}{\beta A - 1} \right) \cong -\frac{\alpha}{\beta} \left[1 + (\beta A)^{-1} \right] \quad (1.17)$$

where the rightmost approximation holds when $|\beta A| \gg 1$. Eq.(1.17) gives an estimate of the relative error with respect to the ideal transfer function $(-\alpha/\beta)$:

$$|\varepsilon_{AL}| \equiv \left| \frac{\Delta A_L}{A_L} \right| \cong |\beta A|^{-1} \quad (1.18)$$

For example, if we need to design a closed loop transfer function such that $A_L=1$ (unity gain amplifier or buffer), we simply can make $\alpha=1$, $\beta=-1$. Then, if we require an accuracy better than 1%, we simply have to guarantee that $A>100$. Similarly, it can be shown that to get the same accuracy (1%) but with an overall gain of 100 (e.g. $\alpha=1$, $\beta=-0.01$), we need a block “A” with at least a gain of 10^4 . The requirement on $|\beta A|$ deriving from the relative error specification through (1.18) should clearly hold over the whole frequency interval of interest.

Feedback systems in the electrical domain.

When dealing with real electrical networks, the analysis is more complicated, since signals are embodied by voltages and/or currents that should satisfy Kirchhoff laws: blocks are often bidirectional and loading effects occur when blocks are connected. Figure **Error! Use the Home tab to apply Titolo 1 to the text that you want to appear here..9(a)** shows a typical implementation of the system of Fig.**Error! Use the Home tab to apply Titolo 1 to the text that you want to appear here..8** using electrical blocks.

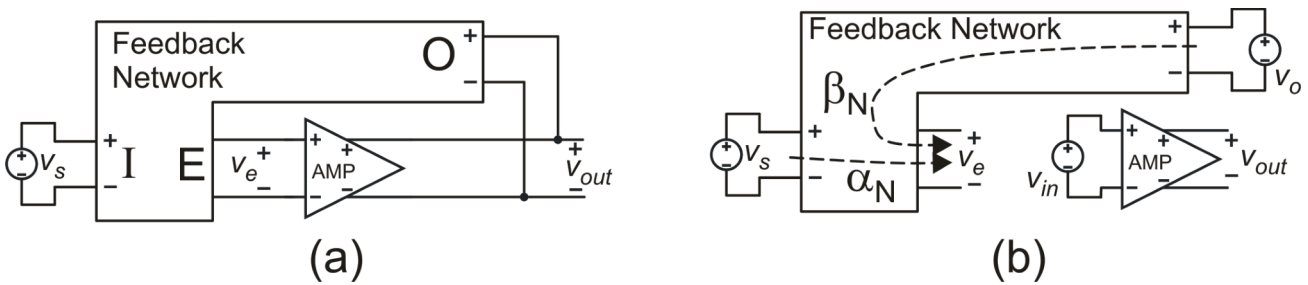

Fig. 1.9. Error! Use the Home tab to apply Titolo 1 to the text that you want to appear here..9. (a) Implementation of the block diagram of Fig. Error! Use the Home tab to apply Titolo 1 to the text that you want to appear here..8 in the electrical domain; (b) definition of the Feedback network transfer functions.

In Fig. Error! Use the Home tab to apply Titolo 1 to the text that you want to appear here..9(b), the amplifier have been disconnected from the feedback network in order to measure the individual transfer functions of the blocks. Let us indicate with α_N and β_N the transfer functions from the input and output ports, I and O, respectively, to the error port (E) of the feedback network and with A_{OL} the amplifier gain. These transfer functions, illustrated in Fig. Error! Use the Home tab to apply Titolo 1 to the text that you want to appear here..9(b), are defined by:

$$\alpha_N \equiv \left(\frac{v_e}{v_s} \right)_{v_o=0} ; \quad \beta_N \equiv \left(\frac{v_e}{v_o} \right)_{v_s=0} ; \quad A_{OL} = \left(\frac{v_{out}}{v_{in}} \right) \quad (1.19)$$

It would be desirable to model the circuit of Fig. Error! Use the Home tab to apply Titolo 1 to the text that you want to appear here..9(a) with the block diagram of Fig. Error! Use the Home tab to apply Titolo 1 to the text that you want to appear here..8, where $\alpha = \alpha_N$, $\beta = \beta_N$ and $A = A_{OL}$, so that Eqns. (1.16-1.18) would be applicable. Unfortunately, such a simple schematization is not correct since:

- The amplifier gain depends on the loading effect of the feedback network.
- The feedback network transfer functions, calculated with the amplifier unconnected as in Fig. Error! Use the Home tab to apply Titolo 1 to the text that you want to appear here..9(b), are different from the actual transfer functions occurring in the closed loop circuit of Fig. Error! Use the Home tab to apply Titolo 1 to the text that you want to appear here..9(a).
- Blocks are not unidirectional.

A possible approach is given by the method introduced by B. Pellegrini and described in refs.[2,3], denominated also Pellegrini's cut-insertion theorem [4,5], by which it is possible to obtain the network of Fig. Error! Use the Home tab to apply Titolo 1 to the text that you want to appear here..10, where the following network transfer functions can be defined:

$$\begin{aligned}
 Z_i &= \left(\frac{v_p}{i_p} \right)_{v_s=0} ; \quad \beta \equiv \left(\frac{v_r}{v_{out}} \right)_{v_s=0} ; \quad A = \left(\frac{v_{out}}{v_p} \right)_{v_s=0} \\
 \gamma &= \left(\frac{v_{out}}{v_s} \right)_{v_p=0} ; \quad \alpha \equiv \left(\frac{v_r}{v_s} \right)_{v_p=0} \quad \rho = \left(\frac{i_p}{v_s} \right)_{v_p=0}
 \end{aligned}
 \tag{1.20}$$

It can be shown [2-4] that the network of Fig. Error! Use the Home tab to apply Titolo 1 to the text that you want to appear here..10 is equivalent to the original network in Fig. Error! Use the Home tab to apply Titolo 1 to the text that you want to appear here..9(a)

if $v_r=v_p$ and $i_r=i_p$, which require that the following conditions hold true:

$$v_p = \frac{\alpha}{1-\beta A} v_s ; \quad \frac{1}{Z_p} = \frac{1}{Z_i} + \frac{\rho}{\alpha} (1-\beta A)
 \tag{1.21}$$

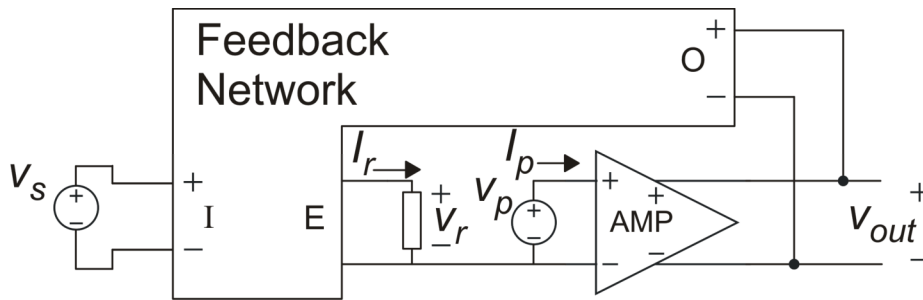

Fig. Error! Use the Home tab to apply Titolo 1 to the text that you want to appear here..10. Application of the cut-insertion method to the network of Fig. Error! Use the Home tab to apply Titolo 1 to the text that you want to appear here..9.

In these conditions, the overall closed loop transfer function of the network is given by:

$$\frac{v_{out}}{v_s} = -\frac{\alpha}{\beta} \frac{\beta A}{\beta A - 1} + \gamma
 \tag{1.22}$$

Equation, (1.22) is very similar to (1.16), except for the term γ , which represents a feed-forward path for the signal v_s . This approach constitutes a powerful method for the analysis of the network, since it allows splitting the overall transfer function into simpler network functions. The study of the system stability is also much facilitated. Complications might arise from the calculation of Z_p , but, in most

practical cases, the amplifier can be generally approximated as a unidirectional block, so that $\rho=0$, and Z_p is simply the input impedance of the amplifier.

In order to exploit the significant simplification offered by the cut-insertion theorem also for design purposes, the following conditions would be desirable:

- the feed-forward term γ should be negligible, since it introduces an error, with respect to the nominal $-\alpha/\beta$ transfer function, whose magnitude is not affected by the βA term.
- the network functions α and β should coincide with α_N and β_N , respectively, calculated as in Fig. Error! Use the Home tab to apply Titolo 1 to the text that you want to appear here..9(b), in order to greatly simplify the design of the feedback network and make it as independent as possible of the amplifier characteristics.

Both requirements are met if $\rho=0$ and the following conditions hold true:

$$|Z_i| \gg |Z_e| \quad (1.23)$$

$$|Z_{out}| \ll |Z_o| \quad (1.24)$$

where, with reference to Fig. Error! Use the Home tab to apply Titolo 1 to the text that you want to appear here..9:

- Z_{out} and Z_i are the output and input impedances of the amplifier, respectively;
- Z_o is the impedance seen across port O when port I is shorted and port E is loaded by $Z_p (=Z_i)$;
- Z_e is the impedance seen across port E when port I is shorted and port O is loaded by Z_{out} .

While Eq.(1.23) can be assumed to be verified, at least as a first approximation, (1.24) is difficult to fulfill with modern, low voltage operational amplifier, where, in order to maximize the output swing, common drain output stages are used, with output resistances in the range of several tens of $k\Omega$. In this case, γ is often non-negligible and α strongly depends on the amplifier output resistance, which is a parameter that is difficult to control in the design phase.

Nevertheless, it is interesting to observe that, according to (1.22), if $|\beta A|$ tends to infinity, the closed loop transfer function tends to:

$$\lim_{|\beta A| \rightarrow \infty} \left(\frac{v_{out}}{v_s} \right) = -\frac{\alpha^*}{\beta} \quad (1.25)$$

where α^* is v_r/v_s calculated with $v_p=0$ and the output port short-circuited. Note that α^* does not depend on the amplifier output impedance and coincides with α_N in the case that the input impedance of the amplifier is much larger than port E output impedance, i.e. condition (1.23) holds.

With this alternative definition of α , the closed loop transfer function tends to a simple expression just as in the case of the ideal block diagram of Fig. Error! Use the Home tab to apply Titolo 1 to the text that you want to appear here..8. In particular, Eqn.(1.25) is not affected by the feed-forward term γ .

In order to demonstrate Eqn.(1.25) let us start by defining the two quantities α^* and β^* , using the network of Fig. Error! Use the Home tab to apply Titolo 1 to the text that you want to appear here..11, which is more general with respect to that of Fig. Error! Use the Home tab to apply Titolo 1 to the text that you want to appear here..10, since it does not specify whether or not an unilateral block as the amplifier “AMP” is present. The network in Fig. Error! Use the Home tab to apply Titolo 1 to the text that you want to appear here..11 is a generic network in which a cut has been applied to a couple of nodes, as in the general application of the cut-insertion theorem.

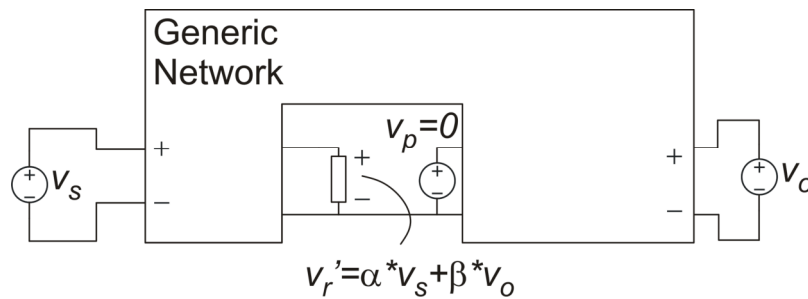

Fig. Error! Use the Home tab to apply Titolo 1 to the text that you want to appear here..11. Network used for calculation of the definition of α^* and β^* .

We keep v_p turned off and place an ideal voltage source v_o across the output terminations. This is clearly possible only if the impedance seen across the output terminals is not zero, which is true in all real cases. Then:

$$\alpha^* \equiv \left(\frac{v_r}{v_s} \right)_{v_p, v_o=0} ; \beta^* \equiv \left(\frac{v_r}{v_o} \right)_{v_p, v_s=0} \tag{1.26}$$

Now, let us consider Fig. Error! Use the Home tab to apply Titolo 1 to the text that you want to appear here..12 that shows the network used for determining parameters α and γ , according to original definitions (1.20) of the cut-insertion theorem. According to the substitution theorem, if we place an ideal voltage source of value γv_s across the output termination, (leaving v_s turned on), the network shown in Fig. 5 is not altered and thus the value of v_r does not change. We can then consider the

network of Fig. Error! Use the Home tab to apply Titolo 1 to the text that you want to appear here..12 as a particular case of Fig. Error! Use the Home tab to apply Titolo 1 to the text that you want to appear here..11, with $v_o = \gamma v_s$. Then:

$$\alpha v_s = v_r \Big|_{v_p=0} = v_r' \Big|_{v_p=0, v_o=\gamma v_s} = \alpha^* v_s + \beta^* \gamma v_s \tag{1.27}$$

Since this expression must hold true for whatever value of v_s , then the following relationship can be found:

$$\alpha = \alpha^* + \beta^* \gamma \tag{1.28}$$

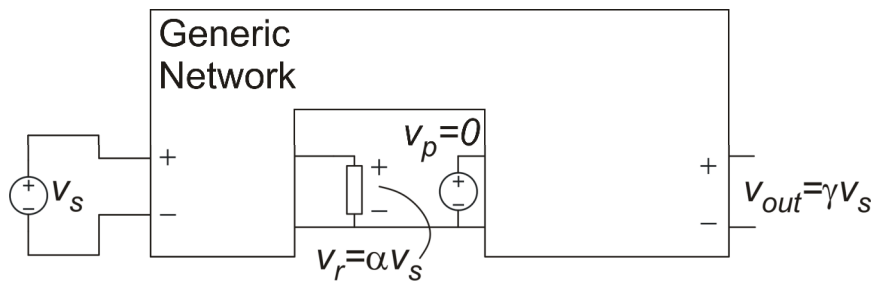

Fig. Error! Use the Home tab to apply Titolo 1 to the text that you want to appear here..12. Network used for calculation of α and γ .

Substituting this expression of α into (1.22) we get:

$$\frac{v_{out}}{v_s} = -\frac{(\alpha^* + \gamma\beta^*)}{\beta} \frac{\beta A}{\beta A - 1} + \gamma = -\frac{\alpha^*}{\beta} \frac{\beta A}{\beta A - 1} + \frac{\gamma}{1 - \beta A} + \gamma \frac{(\beta^* - \beta)A}{1 - \beta A} \tag{1.29}$$

In order to find a further simplification, it is useful to find the relationship between β and β^* .

First, we refer to Fig. Error! Use the Home tab to apply Titolo 1 to the text that you want to appear here..13, where the voltage v_r (indicated here with v_r') is expressed as a function of v_p and v_o (with $v_s=0$). Clearly, when only v_o is on, we are in the same conditions of Fig. Error! Use the Home

tab to apply Titolo 1 to the text that you want to appear here..11 with $v_s=0$, then the transfer function from v_o to v_r is β^* .

We introduce a new transfer function between v_p and v_r with $v_s=0$ and $v_o=0$ (i.e. output termination short circuited):

$$\eta \equiv \left(\frac{v_r}{v_p} \right)_{v_s, v_o=0} \tag{1.30}$$

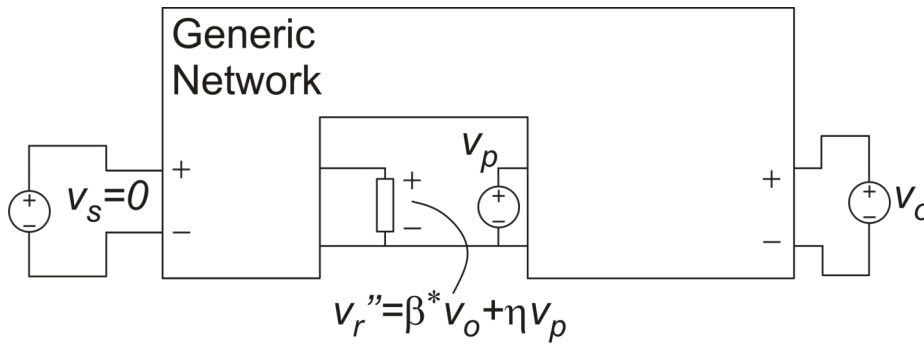

Fig. Error! Use the Home tab to apply Titolo 1 to the text that you want to appear here..13. Network used for calculation of the dependence of v_r on v_p and v_o for $v_s=0$

Then, let us consider Fig. Error! Use the Home tab to apply Titolo 1 to the text that you want to appear here..14, showing the original configuration used to calculate parameter β . Clearly, according to the substitution theorem, v_r does not change if a voltage source of value $A v_p$ is placed across the output termination. This corresponds to setting $v_o = A v_p$ in Fig. Error! Use the Home tab to apply Titolo 1 to the text that you want to appear here..13, therefore:

$$\beta A v_p = v_r |_{v_s=0} = v_r'' |_{v_p=0, v_o=A v_p} = \beta^* A v_p + \eta v_p \tag{1.31}$$

From equality (1.31), we find:

$$\beta^* = \beta - \frac{\eta}{A} \tag{1.32}$$

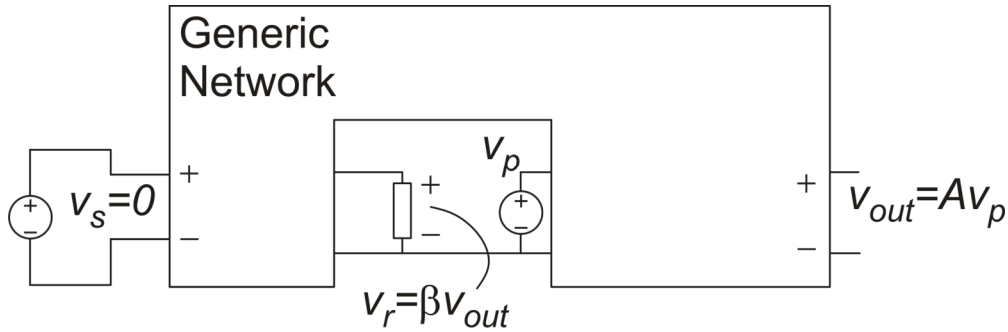

Fig. Error! Use the Home tab to apply Titolo 1 to the text that you want to appear here..14. Network used for definition of A and β .

So far, we have considered a very general case, with no restrictions on the network to which the cut-insertion theorem is applied. Now, let us come back to the case of interest for op-amp applications, represented by Fig. Error! Use the Home tab to apply Titolo 1 to the text that you want to appear here..10, i.e. a circuit with $\rho=0$ and full separation between the amplifier and the feedback network. We observe that, in this condition, voltage v_p can affect v_r only through the output termination. Since definition of η , given by (1.30), requires that the output termination is short-circuited, then η must be zero.

As a result:

$$\beta^* = \beta \tag{1.33}$$

It should be observed that, Eq. (1.33) can be directly obtained from the definitions (1.20) and (1.26) of β and β^* , respectively, by simple inspection of Fig. Error! Use the Home tab to apply Titolo 1 to the text that you want to appear here..10.

With (1.33), Eq. (1.29) becomes:

$$\frac{v_{out}}{v_s} = -\frac{\alpha^*}{\beta} \frac{\beta A}{\beta A - 1} + \frac{\gamma}{1 - \beta A} \tag{1.34}$$

It can be easily shown that the block diagram corresponding to (1.34) is that of Fig. Error! Use the Home tab to apply Titolo 1 to the text that you want to appear here..15:

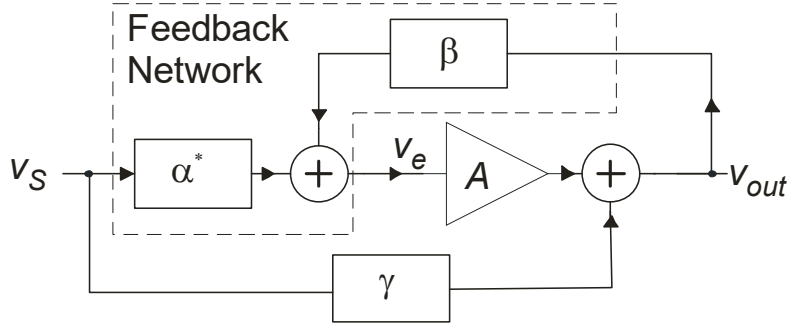

Fig. Error! Use the Home tab to apply Titolo 1 to the text that you want to appear here..15. Block diagram equivalent to Eqn.(1.34).

If we calculate the limit of (1.34) for $|\beta A|$ that tends to infinity, we just obtain Eqn. (1.25). For $|\beta A| \gg 1$, the relative error with respect to the ideal transfer function $(-\alpha^*/\beta)$ is given by:

$$|\epsilon_{AL}| \equiv \left| \frac{\Delta A_L}{A_L} \right| \cong |\beta A|^{-1} \left| 1 + \frac{\gamma \beta}{\alpha^*} \right| \leq |\beta A|^{-1} \left(1 + \left| \frac{\gamma}{A_L} \right| \right) \quad (1.35)$$

Using Eq. (1.35) it is possible to estimate the minimum value of the gain loop $|\beta A|$ to make the error smaller than specified by the design constraints. Clearly, the value of γ should be known to obtain a precise estimate of the error using (1.35). In practice, considering the typical implementations of the network in fig. Error! Use the Home tab to apply Titolo 1 to the text that you want to appear here..10, γ is due to passive components, so that $|\gamma| \leq 1$. Considering also that, for the frequencies of interest, generally $|A_L| \geq 1$, the term $|\gamma/A_L|$ is generally ≤ 1 . Then, $|\beta A|^{-1}$ is an acceptable approximation of the relative error, at least in terms of order of magnitude.

Finally, it is possible to remove the dependence of the amplifier input impedance from the asymptotic (ideal) transfer function $(-\alpha^*/\beta)$. To do this, let us start by considering that, due to (1.33), $\beta^* = \beta$. Then, note that functions are obtained by stimulating the feedback network from port I and port O, respectively, considering as output quantity the voltage at port E. The definition of β is just the same as, respectively, but for α_N and β_N port E is open, while for β^* and α^* port E is closed on the amplifier input impedance ($Z_p = Z_{in}$). Then we can write the following relationships:

$$\begin{cases} \alpha^* = \alpha_N \frac{Z_{in}}{Z_e + Z_{in}} \\ \beta = \beta^* = \beta_N \frac{Z_{in}}{Z_e + Z_{in}} \end{cases} \quad (1.36).$$

From (1.36), the following property can be immediately derived:

$$\frac{\alpha^*}{\beta^*} = \frac{\alpha^*}{\beta} = \frac{\alpha_N}{\beta_N} \quad (1.37)$$

A possible practical design flow based on the cut-insertion theorem is summarized by the following two steps

1. Design the feedback network in such a way that the target design function is given by $-\alpha_N/\beta_N$.
2. Design (or choose) the amplifier in such that, once loaded by the feedback network, its gain is still large enough to obtain a $|\beta^*A|$ product large enough to make the relative error, given by (1.35), below the maximum allowed value; Note that β^* , differently from the α^*/β^* ratio, is affected by the input impedance of the amplifier.

References.

- [1] S. R. Parker, "Sensitivity Analysis and Models of Non-Linear Circuits", *IEEE Trans. on Circuit Theory*, vol. CT-19, pp. 443-447, November 1969.
- [2] B. Pellegrini, "Considerations on the feedback theory," *Alta Frequenza*, vol. 41, no. 11, pp. 825–820, Nov. 1972. <http://brahms.iet.unipi.it/elan/scompos.pdf>.
- [3] B. Pellegrini, "Improved Feedback Theory", *IEEE Trans. on Circuit and Systems —I: Regular Papers*, vol. 56, no. 9, September 2009.
- [4] Wikipedia, "Cut-Insertion theorem", URL: http://en.wikipedia.org/wiki/Cut-insertion_theorem
- [5] J. Millman, A. Grabel, P. Terreni, "Elettronica di Millman", The Mcgraw-Hill Companies, 4th/ed 2008, p. 823.