

WDM Solutions

From Do-It-Yourself to Carrier Grade WDM Solutions



Connectivity Unlimited™

what is WDM?

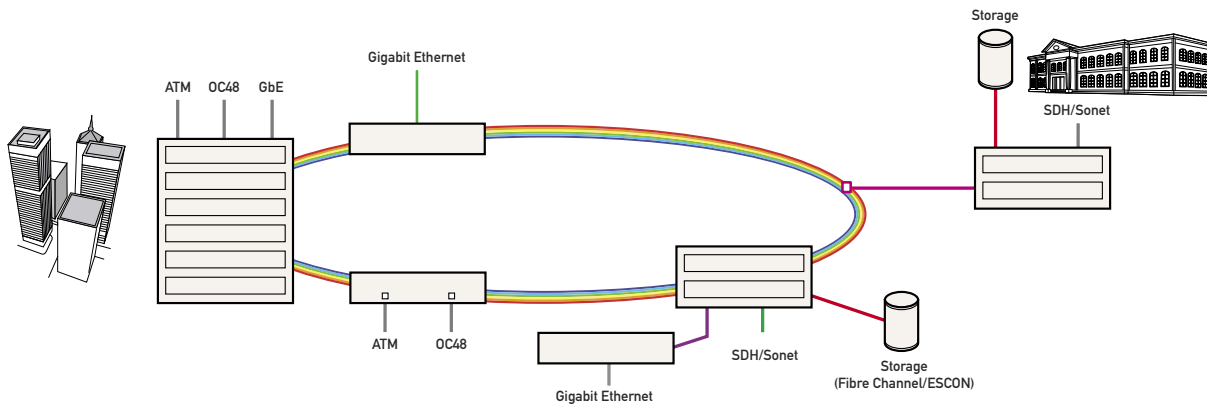

Wavelength Division Multiplexing (WDM) is a method of transmitting data from different sources over the same fiber optic link at the same time whereby each data channel is carried on its own unique wavelength. The result is a link with an aggregate bandwidth that increases with the number of wavelengths employed. In this way WDM technology can maximize the use of the fiber optic infrastructure that is available; what would normally require two or more fiber links instead requires only one.

>> CWDM vs. DWDM

There are two types of WDM implementations: Dense Wave Division Multiplexing (DWDM) and Coarse Wave Division Multiplexing (CWDM). DWDM systems utilize temperature-stabilized lasers and narrow band filters to achieve narrow channel spacing of 0.8 nm or less, enabling the transmission of 16 or more wavelengths/data channels within a given color spectrum. CWDM systems in comparison use non-stabilized lasers along with broadband filters for wider channel spacing of 20 nm, allowing for up to 16 transmitted wavelengths.

In general, DWDM is the best choice for applications where channel density/bandwidth is of high priority. At the same time, CWDM remains an excellent option for applications where deployment costs are to be considered.

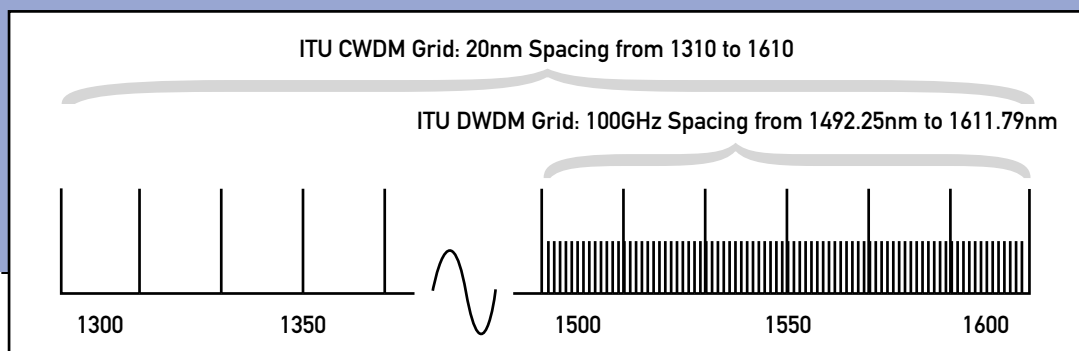

>> the MRV advantage

MRV is the only vendor to provide a complete solution for media conversion, distance extension, redundant links, Wave-Division Multiplexing and many other applications with integrated fiber optic technology.

We accomplish this by maintaining control over the process from wafer to system, incorporating our own technology and best-of-breed 3rd party technology in our systems.



>> WDM concepts

Digital Diagnostics: Provides real time monitoring of transmit and receive power, temperature and voltage, with alarm and warning thresholds for preemptive control.

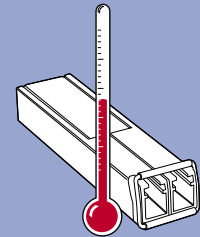

Multiplexer: An optical device that combines channels of different wavelengths such that they all pass through a single optical fiber.

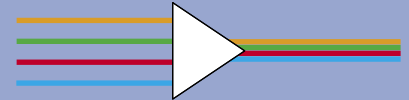

Demultiplexer: An optical device that separates combined (multiplexed) channels of different wavelengths such that they each emerge through a different fiber- the inverse of a multiplexer.

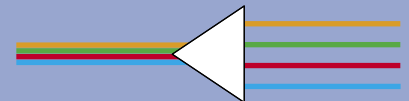

Add/Drop Multiplexer: A multiplexer/demultiplexer that adds or drops one or more specific wavelengths at a given point along a WDM link while allowing all other wavelengths to pass through unchanged.



Optical Amplifier: A device that amplifies an incoming multi-wavelength optical signal without needing to first convert it to electrical form.



Dispersion: The spreading out of light pulses as they travel in an optical fiber. May result in the degradation of the data signal to the point that the receiving end cannot decode it. Dispersion limits the distance between signal regenerators. MRV provides these as well as low dispersion DWDM interfaces.

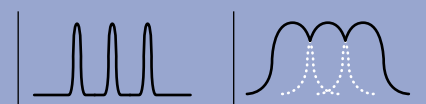

>> fiber driver pluggable-based WDM

With the combined benefits of SFP interfaces, multi-rate, multi-port transponders and passive Mux/Demux technology incorporated into a modular, "building block" architecture, the Fiber Driver Pluggable Modular WDM system delivers an unprecedented level of WDM flexibility and scalability, including distances of 100km and resilient ring topologies, while lowering deployment and maintenance costs, reducing parts inventory and improving ROI.

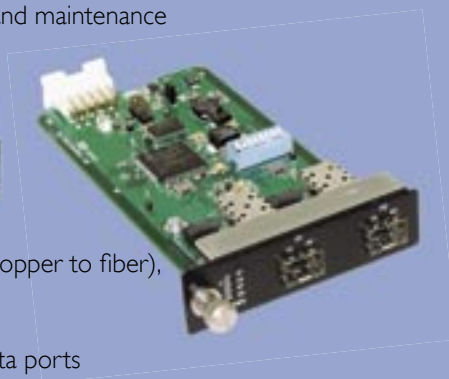

SFP-Based Transponders

- Multifunctional WDM connectivity – media conversion (multimode to single-mode, copper to fiber), wavelength conversion, signal boosting and more
- Pluggable CWDM SFP interfaces
- High density IRU system with 16 Dual-SFP channels or 1-slot module with 2 SFP data ports
- Rate independent with 2R/3R signal conditioning– 100 Mbps to 2.7 Gbps
- Support for SFP digital diagnostics as per SFF-8472
- Compatible with Fiber Driver Passive Mux/Demux modules
- Fits any Fiber Driver pluggable module chassis
- Modular version fits any Fiber Driver pluggable module chassis

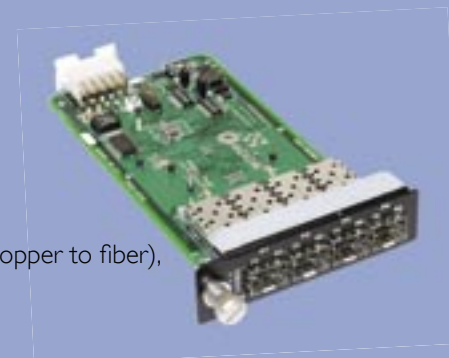

SFP-Based Cross Connects

- Multifunctional WDM connectivity – media conversion (multimode to single-mode, copper to fiber), wavelength conversion, signal boosting, signal repeating and more
- Pluggable CWDM SFP interfaces
- High-density IRU system with 32 SFP ports or 1-slot module with 4 SFP data ports
- Per channel selectable data rate transponder with 2R/3R signal regeneration – 100 Mbps to 2.7 Gbps
- Crossbar connectivity – any port to any port, port-to-multiport, and trunk switching
- Support for SFP digital diagnostics as per SFF-8472
- Compatible with Fiber Driver Passive Mux/Demux modules
- Modular version fits any Fiber Driver pluggable module chassis
- IRU version supports 2 protocol independent monitoring ports

Passive CWDM Mux/Demux Modules

- Solutions for multiplexing/demultiplexing 2, 4, 8 or 16 Full Duplex data channels, up to 32 channels using single fiber technology
- Transparent, protocol independent operation
- Secure physical separation between data channels
- Minimal dB loss per link
- Fully passive device - requires no power
- High-density form factor – up to 8 channels in a 1-slot module, 16 channels in two slots



NC316BU-16 -
16-slot, rack mount chassis

>> LD - CWDM/DWDM modular solutions

Overview

The LD (LambdaDriver®) series consists of multi-functional, compact and modular CWDM/DWDM systems specifically designed for metropolitan service providers and enterprises requiring a flexible, cost-effective system to multiplex, transport and switch high-speed data, storage, video and voice applications. The LD systems can create up to 64 independent virtual fiber links over a single pair of fibers over distances of up to 100 km. The system supports different network topologies such as Point-to-Point, Star, Linear Optical Add/Drop Mux and Ring. Service providers and Enterprise customers deploy the LD systems to maximize the bandwidth and service flexibility of their networks.

The LD WDM systems use a modular architecture comprising three different chassis that are rack-mountable shelf:

- **LD1600** chassis can host 16 transponders plus OADMs, Muxes/Dmuxes, 1+1 redundancy, service and 2 management modules (for redundancy)
- **The LD800** chassis can host 11 transponders, OADMs, Mux/Dmux, 1+1 redundancy, service module and 1 management module
- **The LD400** chassis can host 5 transponders, OADMs, Mux/Dmux, 1+1 redundancy, service module and 1 management module

Modular System

- High density form factor supports
 - 1 to 16 CWDM channels
 - 1 to 64 DWDM channels
 - Hybrid CWDM and DWDM for transparent upgrade
- The modules are hot swappable, allowing scalable, in-service expansion or channel maintenance
- Multifunctional transponders provide transparent light paths compliant to ITU-T grid CWDM/DWDM wavelengths
- A transponder module can be used in any LD family chassis
- Rate independent: protocols of all data rates in the range of 10 Mbps to 2.7 Gbps are supported
- Protocol transparent: Mix different protocols such as E3/DS3, SONET/SDH, Fast Ethernet, ESCON, Gigabit Ethernet, Fibre Channel, etc.
- Multifunction, flexible SFP access transponders (TM-xSFP)
- Special low dispersion solution for distances of up to 640 km.
- Additional loop-back and power monitoring functionalities and other diagnosis information
- High availability and redundancy using:
 - Fiber redundancy protection (1+1 protection)
 - O-BPSR and O-UPSR protection support
 - Y-cable and transponder redundancy backup
- Sub-Rate Multiplexing. For example: Four ESCON per wavelength
- Management includes - Optical Service Channel (OSC) for secure in-band management



Passive Optical

- Single Fiber, Single-mode Fiber and Multimode Fiber based Mux/Dmux
- Flexible dual fiber and single fiber OADMs ranging from one to multiple wavelengths, including mix wavelengths
- Boosters, In line and Pre optical amplifiers



>> eWDM-ethernet wdm solutions

MRV's eWDM systems provide a simple, efficient, flexible and cost effective solution for deploying Gigabit Ethernet services in Campus, Metropolitan area access networks, highways, the transportation industry and Cable TV – MSOs.

The Ethernet WDM (eWDM) solution's building blocks are:

- OptiSwitch WDM - pluggable module with WDM SFP
- LDP300 – All Optics Chassis (passive)
- CWDM Optical Add-Drop Multiplexers (OADMs)
- **Easy Deployment and flexible implementation:**
 - Passive Optical Solution - No-power required
 - No configuration needed
 - Can work with standard LD family OADM/MUX modules
 - Interfaces directly to WDM (SFP/GBIC) pluggable optics
- **High availability and redundancy protection:**
 - OADM: O-BPSR and O-UPSR for system and fiber cut protection
 - OptiSwitch GER module for fiber signal redundancy
 - Protocol (RSTP, MPLS) redundancy
- **Investment protection**
 - Enables enterprises and service providers to increase the bandwidth of existing GE optical infrastructure without adding new fibers



>> fixed-form WDM for gigabit ethernet & fibre channel

- Multiplex 4, 8 or 16* gigabit-speed data channels onto one trunk
- Cost effective CWDM technology
- Support for Gigabit Ethernet, Fibre Channel, FICON, ESCON and more
- Link distances of up to 65 km
- Single fiber trunk option (4- and 8-channel)
- Standalone 1U (4- and 8-channel) and rack mountable 2.5U (4-, 8-and 16-channel) chassis
- MRV Communications' exclusive Multimode Extender technology - 4 channels guaranteed to 2 km over Multimode fiber; 8 channels to 1 km!
- SNMP managed, MegaVision Web supported

* Requires either the use of low water peak Single Mode fiber or two 8-channel systems with single-fiber technology



WDM45 - 4 Ports of Gigabit Ethernet or Fibre Channel on a single or dual-strand fiber



WDM88 - 8 Ports of Gigabit Ethernet or Fibre Channel on a single or dual-strand fiber

>> plug-in interfaces



MRVs' Small Form-Factor Pluggable (SFP) and GBIC transceivers provide the high speeds and physical compactness that today's networks require while delivering the deployment, flexibility and inventory control that network administrators demand.

- SFP supports **Digital Diagnostic** SFF-8472 compliant
- Extremely wide variety of solutions available, from short distance to 100km, for a wide range of protocols
- With plug-in interfaces, the same infrastructure meets a vast range of distance and protocol requirements
- Gigabit Ethernet/Fibre Channel GBIC and SFP
 - Copper (RJ-45) modules
 - Fiber (850/1310/1550) modules
 - CWDM colored fiber modules
- OC-48 SFP 1310/1550 and CWDM models
- Serial Digital Interface (SDI)

- Alarm/Warning thresholds allow preemptive solutions before actual problems occur
- Transmit/Receive power monitoring in real-time allows fiber-optic signal quality measurement
- Temperature/Voltage monitoring in real-time allows advanced environment measurement
- Database of configuration parameters (vendor, serial number, wavelength, etc.) for simple inventory control

>> optical add/drop mux cable & accessories



- Environmentally stable
- 20 nm Channel Spacing CWDM
- 100GHz/200GHz Spacing DWDM
- Custom defined specifications
- Low return loss
- Low insertion loss
- ITU standard
- High channel isolation

Applications

- Implement CWDM/DWDM systems without Add-Drop Mux chassis
- Simplified cable management



>> point-to-point configurations

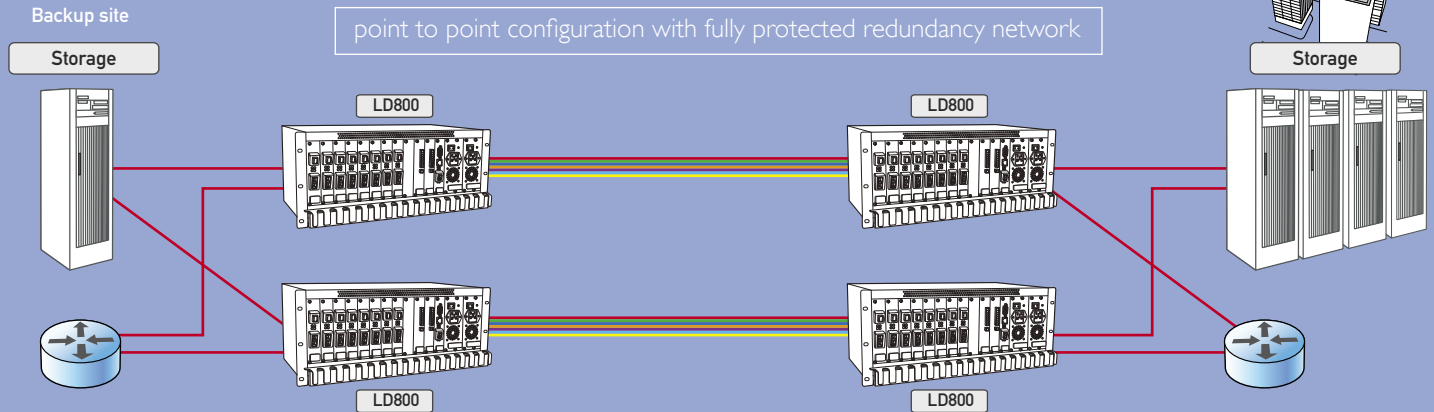

Technology Highlights

- High-Availability: per Device, Lambda & Fiber failover
- 4xESCON on one wavelength
- Redundancy Optical Supervisory Channel (OSC)
- Converged Fault Tolerance networks
- CWDM and DWDM – upto 64 wavelengths

Services

- Disaster recovery over fiber: SAN to SAN and Data to Data
- Finance industry based services
- Data center connectivity
- Enterprise storage networking
- Hybrid (Ethernet, SDH/SONET and SAN services) Metro Access Application
- SAN over MAN
- SDH/SONET over MAN
- Converged Fault Tolerance Networks

point to point configuration with link protection

Technology Highlights

- Flexible, SFP-based WDM
- Transparent (Protocol Independent)
- Optical Supervisory Channel (OSC)
- More Bandwidth over the same fiber infrastructure
- Per Device & Lambda failover

Services

- LAN interconnection services for different services (SDH/SONET, ESCON/Fiber Channel and Ethernet)
- Storage & Data mirroring over fiber

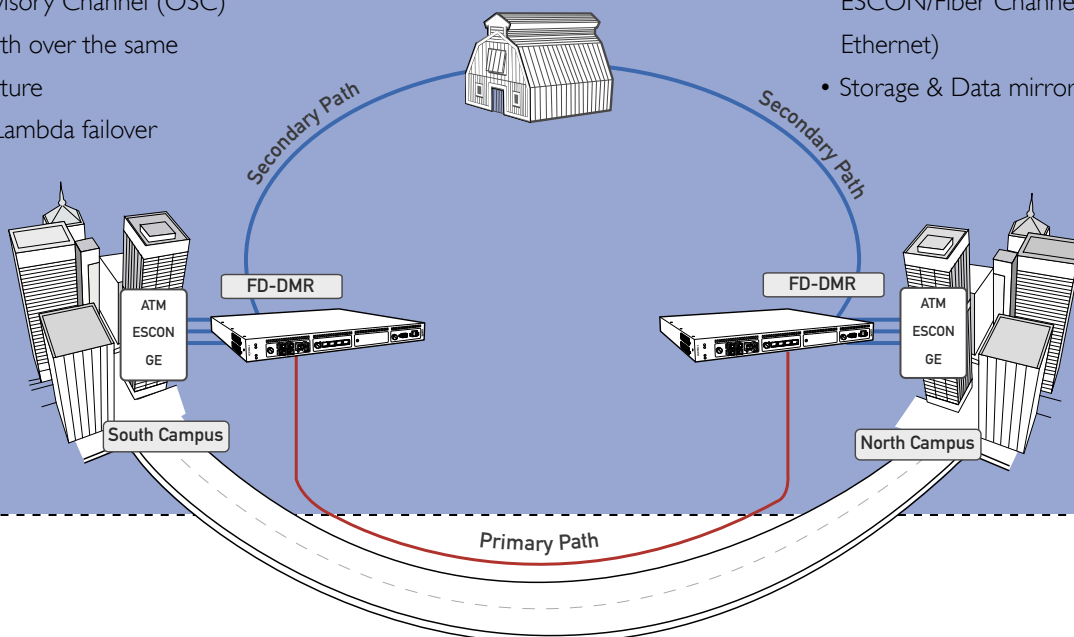

>> CWDM/DWDM star topology

Services

- Connect multiple remote sites to central site connectivity- Connect from a central site to remote locations via direct or indirect fiber. This application, typical in the financial industry, is used mainly for data and storage connectivity.
- Converged networking- WDM networks enable companies to consolidate their data, storage, video and voice applications onto one common infrastructure.
- Disaster recovery over fiber: SAN to SAN and Data to Data
- Multi data center connectivity and campus networks

Technology Highlights

- Transparent interfaces - protocol independent.
- Optical Supervisory Channel (OSC) for out of band secure management
- Upgradeability of up to 64 wavelengths over the same fiber
- Optional: fully protected WDM network
- Per device, Lambda & fiber failover

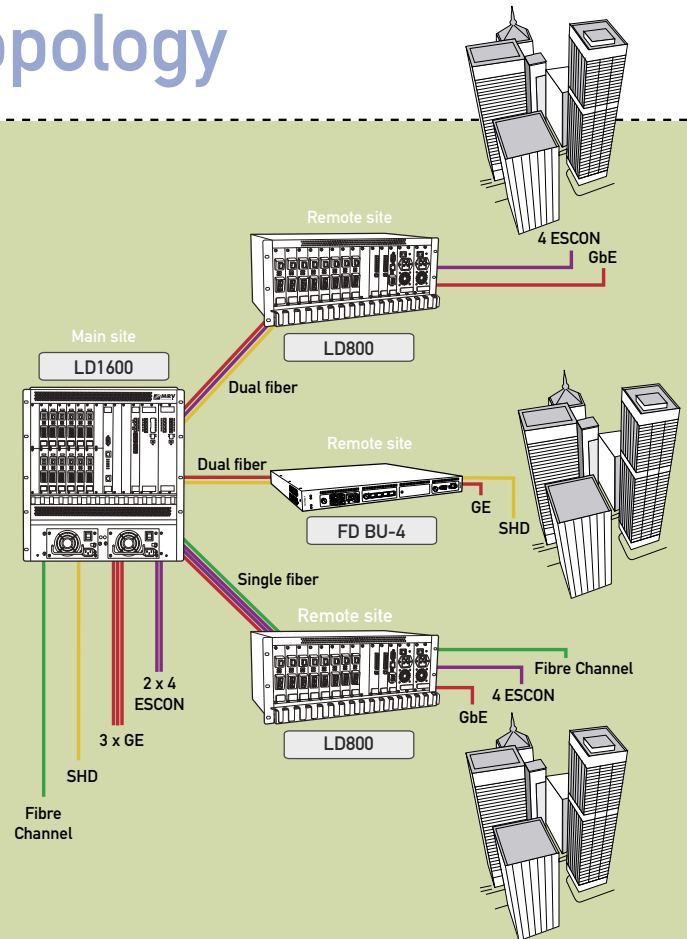

>> multi-gigabit ethernet (eWDM solution)

Services

- Ethernet in Metro Access Networks
- Ethernet WDM Point-to-Point (PtP) or Linear Add/Drop- eWDM is a scalable design that enables the delivery of multi-gigabit traffic in a "pay-as-you-grow" model between buildings or data centers, with the possibility of adding or dropping services along the way.
- Pipeline (GAS, Transportation) Application- Uses Gigabit links to transport data, security video, and voice traffic to connect utilities companies' main locations and sub-locations (e.g. railways, oil/gas pipe lines...).

Technology Highlights

- Passive Optical Add/Drop Multiplexer (OADM) in each sub-location
- MM, SM and Single Fiber based solutions
- Advanced optical amplification and 1,2,3,4, and 8 channels OADM with mix of wavelengths.
- Package of up to 16 Gigabit Ethernet channels onto a single pair of dark fiber
- Use of Gigabit links to transport data, video, and voice traffic

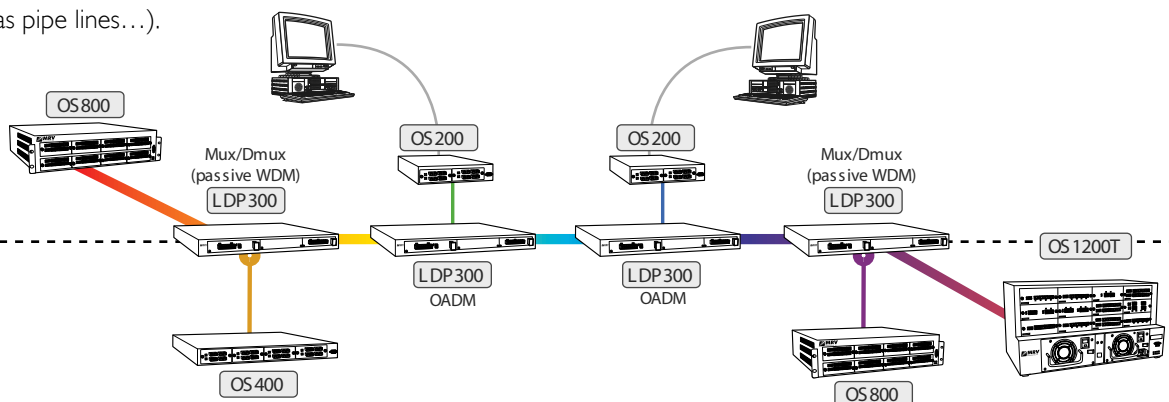

>> fully protected optical network

Services

- Disaster recovery over fiber: SAN to SAN and Data to Data
- Finance industry based services
- Data center connectivity
- Enterprise storage networking
- Hybrid (Ethernet, SDH/SONET and SAN services)
- Metro Access- Ideal networking infrastructure for Carrier-to-Carrier Gigabit Ethernet, SDH/SONET and Storage services to customers in the metro area.
- SAN over MAN
- SDH/SONET over MAN
- Converged Fault Tolerance networks

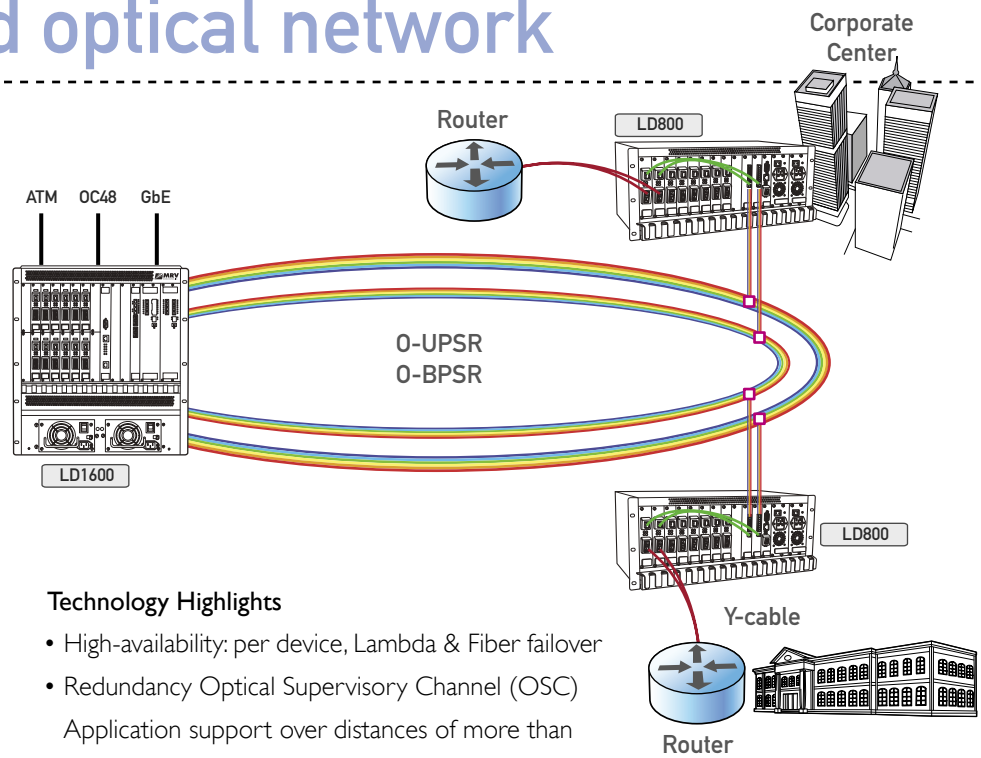

Technology Highlights

- High-availability: per device, Lambda & Fiber failover
- Redundancy Optical Supervisory Channel (OSC)
- Application support over distances of more than 100 kilometers

>> linear oadm

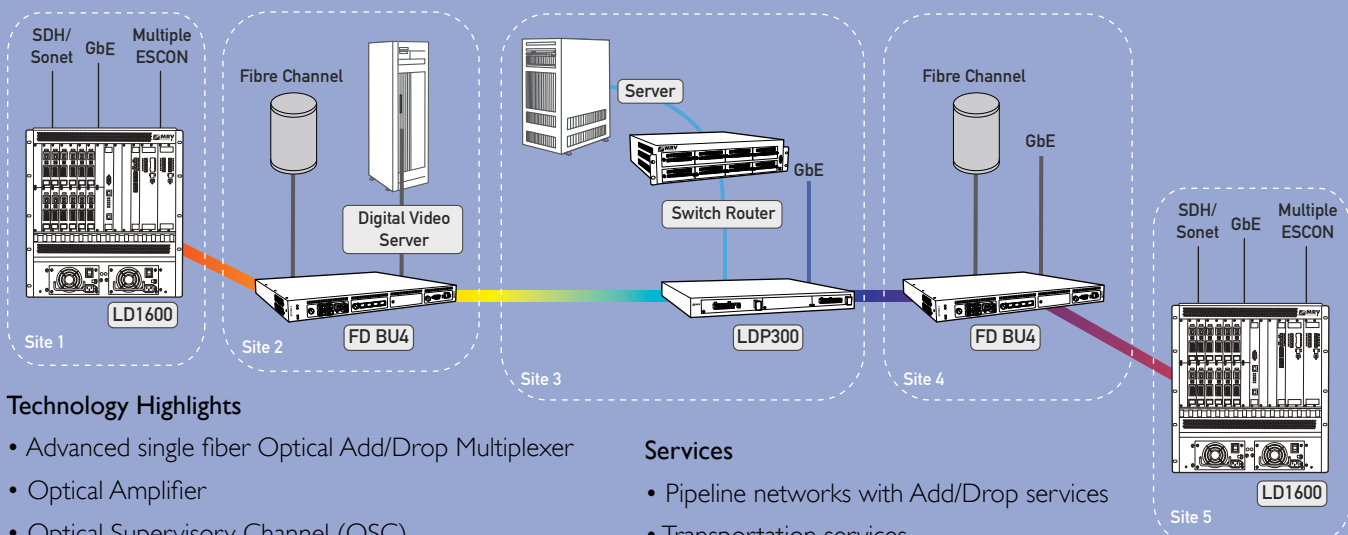

Technology Highlights

- Advanced single fiber Optical Add/Drop Multiplexer
- Optical Amplifier
- Optical Supervisory Channel (OSC)
- Passive WDM can be used in Add/Drop locations
- Upgradeability through CWDM and DWDM
- Highly flexible SFP-based solution

Services

- Pipeline networks with Add/Drop services
- Transportation services
- Converged networking
- Storage and Data based services

>> metro access ring

Services

- Converged networking
- MAN multi-service networks
- Lambda Services - Transparent Lambda Services allow transparent interface upgrades (FE/GE, SDH/SONET, OC-3/12/48), requiring only the MRV optical management platform. Lambda Services provide strategic flexibility to enable network evolution. Carriers can cost-effectively add capacity for their busiest metro rings or target individual links between central offices for additional bandwidth.
- Campuses (multi-site) connectivity

Technology Highlights

- Optical Supervisory Channel (OSC) for secure management
- CWDM and DWDM capabilities
- Adding more services (wavelength) without cutting existing service

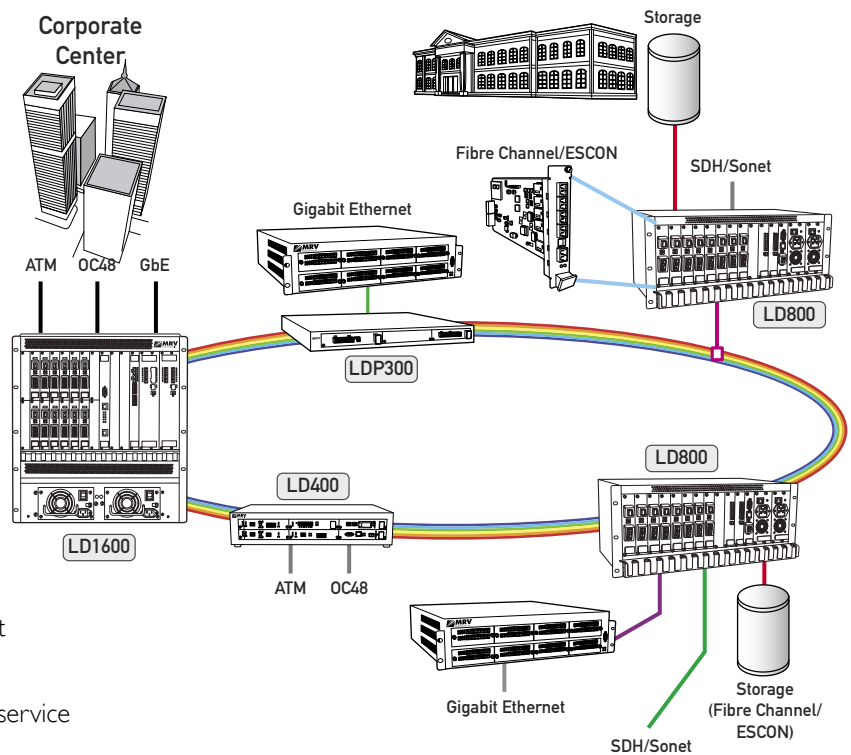

>> reconfigurable networks

- Highly Flexible SFP-Based Solution
- CWDM Trunk Switching for Educational Research Networks and Campus Enterprises
- Use the fiber on an as-needed basis

Enterprise Example

- From 8AM to 9PM Every Day, Use 6Gbps for Gigabit Ethernet and 2Gbps for Fibre Channel
- From 9PM to 8AM every night use 4Gbps for Gigabit Ethernet and 4Gbps for Fibre Channel for faster network backups

Research Networks Example

- Allocate 5Gbps for University to communicate with research lab, and then re-use this bandwidth for other applications when finished

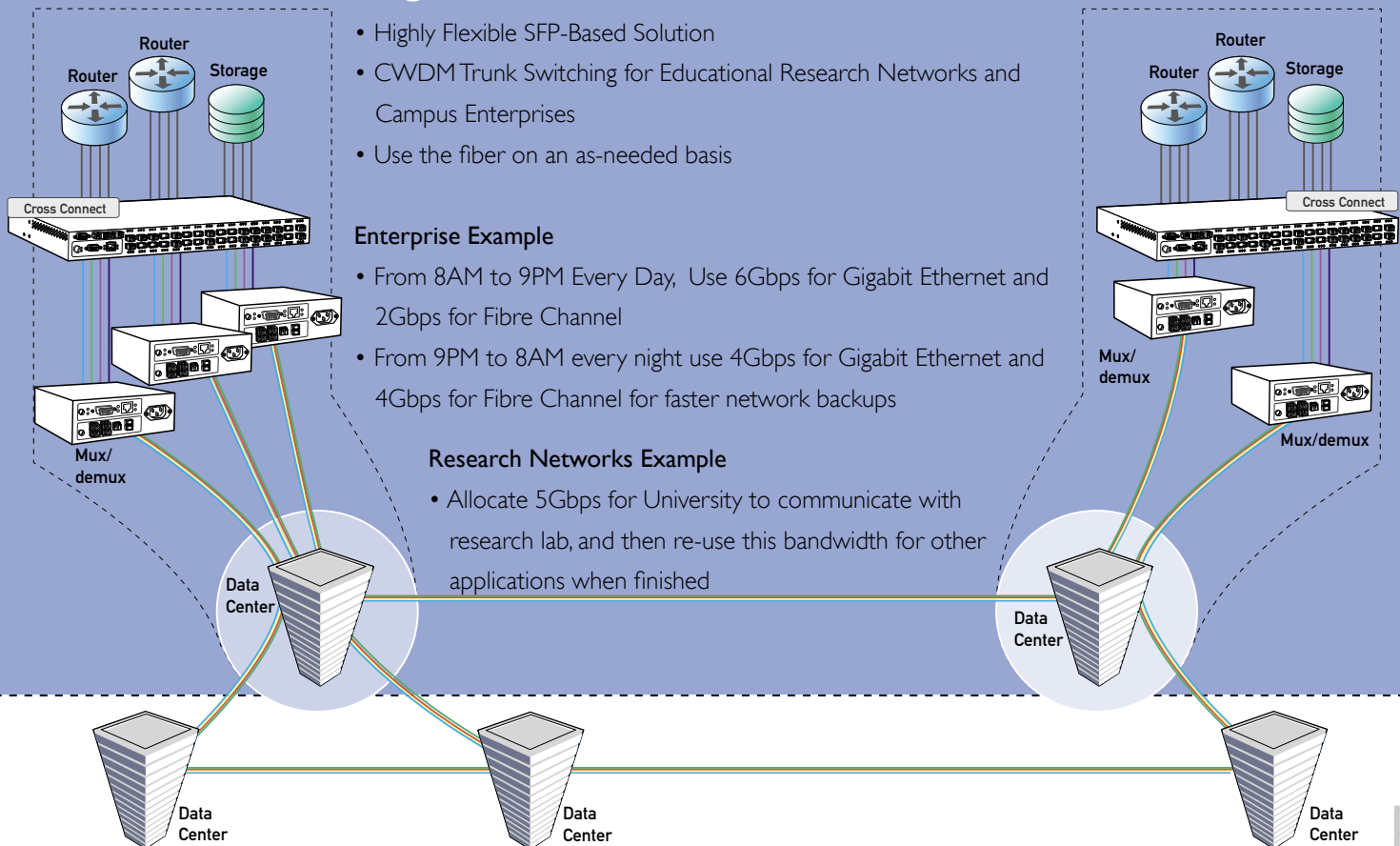

>> how to buy

Fiber Driver Pluggable-Based WDM

NC316	1/2/4/16 slot chassis for Fiber Driver modules
EM316DMR	Dual Multi-Rate SFP Converter up to OC-48 speeds with CDR
EM316PAMULC	One-Slot Passive Mux/Dmux with 8MU Port connectors & LC Trunk connector
NC316-XP32	Media Cross-Connect with selectable data rates, with 32 SFP interfaces
NC316-2SFP/6	Media Connect with 16 pairs of SFP interfaces

Fiber Driver-LD Systems

LD400/800/1600	LD CWDM/DWDM chassis support 4/8/16 wavelengths
LDP300	Passive chassis for Mux/Demux and OADM modules
EM2009	Transponder modules for CWDM/DWDM
TM-CSFP/DSFP	CWDM/DWDM transponders with SFP for access side
TM-L4	Low-Dispersion DWDM modules for long distance
EM800/EM1600	Multiplexer/Demultiplexer modules for CWDM/DWDM
ADCD	Add/drop modules for CWDM/DWDM
EM2009-EM4/P	4 ESCON ports (1310nm,MM) TDM Multiplexer channel card with SFP trunk interface

OptiSwitch eWDM Solution

OS-200/400/800/1200/2400	OptiSwitch Chassis supporting 2/4/8/12 or 24 SFP or GBIC Gigabit Ethernet ports
EM2004-1GE/P	Single port Gigabit 1000Base Uplink with QoS support for the OptiSwitch Family with GBIC/SFP interface

Fiber Driver Fixed CWDM

WDM45	4-Port, 4 Wavelength Wave Division Multiplexer with 4 host ports (Gigabit Ethernet, Fibre Channel, ESCON or FICON)
WDM88	8-Port, 8 Wavelength Wave Division Multiplexer with 8 host ports (Gigabit Ethernet, Fibre Channel, ESCON or FICON)
WDM1616	16-Port, 16 Wavelength Wave Division Multiplexer with 16 host ports (Gigabit Ethernet, Fibre Channel, ESCON or FICON)

Plug-in Optics and Accessories

GBIC-CW	CWDM GBIC for Gigabit Ethernet or Fibre Channel
SFP-GDCW	CWDM SFP for Gigabit Ethernet or Fibre Channel
SFP-48DW	CWDM SFP for OC-48
ADCP	Single Channel DSC Pluggable OADM at CWDM Wavelength with SC connectors

Founded in 1988, MRV Communications, Inc. (Nasdaq: MRVC) is a leading supplier of network infrastructure equipment and services for networks that scale in size, speed, distance and complexity. The company's switches, routers, and optical transport systems, including free space optics (FSO) operate some of the world's largest networks, and our remote presence equipment manages data centers comprising up to tens of thousands of network elements.

Visit us on the Web at: www.mrv.com

Contact your local sales representative at sales@mrv.com

MRV-AN-WDM-081103



Connectivity Unlimited™