

SISTEMI EMBEDDED

Computer Organization
“Central” Processing Unit (CPU)

Federico Baronti

Last version: 20180515

Processing Unit

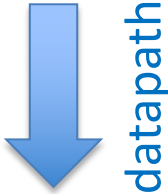
- A processor reads program instructions from the computer's memory and executes them. This includes the following basic phases:
 - **Fetching and decoding** the instruction
 - **Executing** the instruction, which includes:
 1. Reading one or more registers (in the register file)
 2. Doing some computation (in the ALU)
 3. Accessing the memory
 4. Writing a register (in the register file)
- 

Processor's building blocks

- PC provides instruction address
- Instruction is fetched into IR
- Instruction address generator updates PC
- ALU performs some computation during execution
- Control circuitry interprets instruction and generates control signals to perform the actions needed.

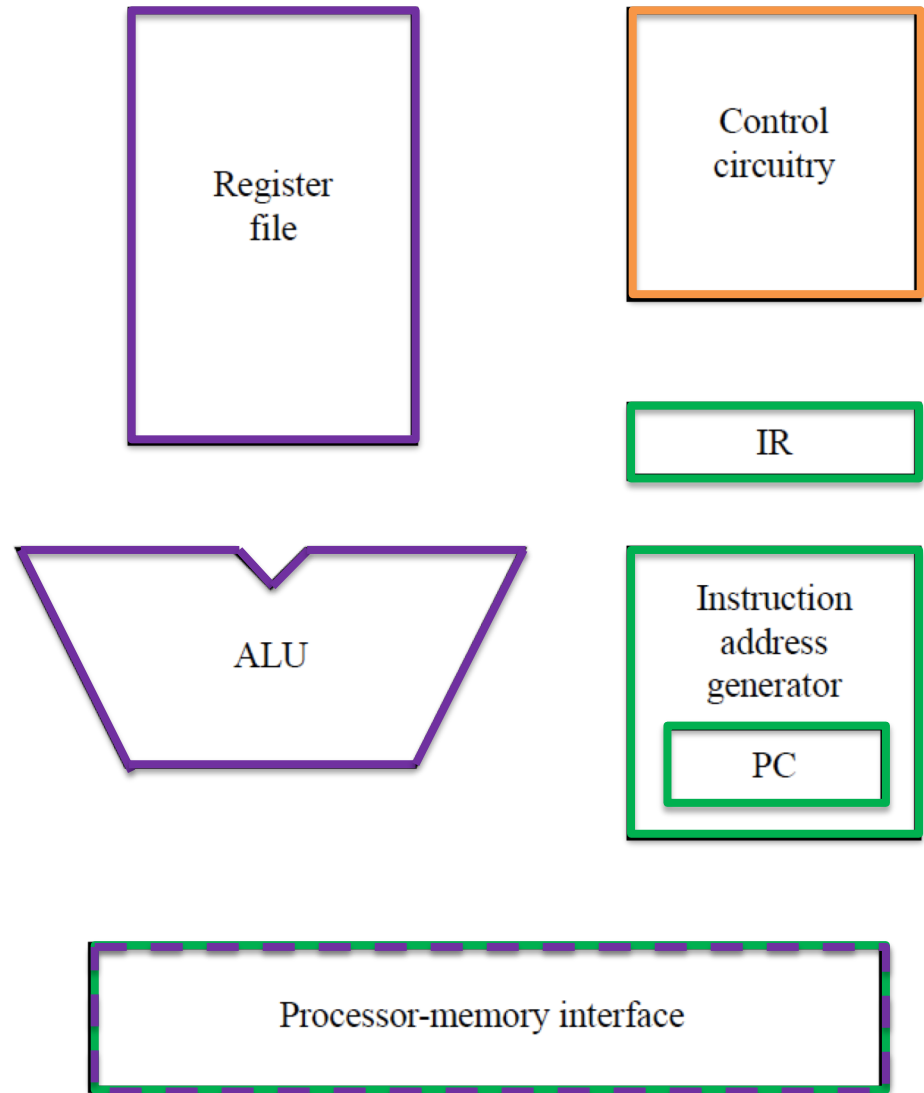

A digital processing system

- datapath

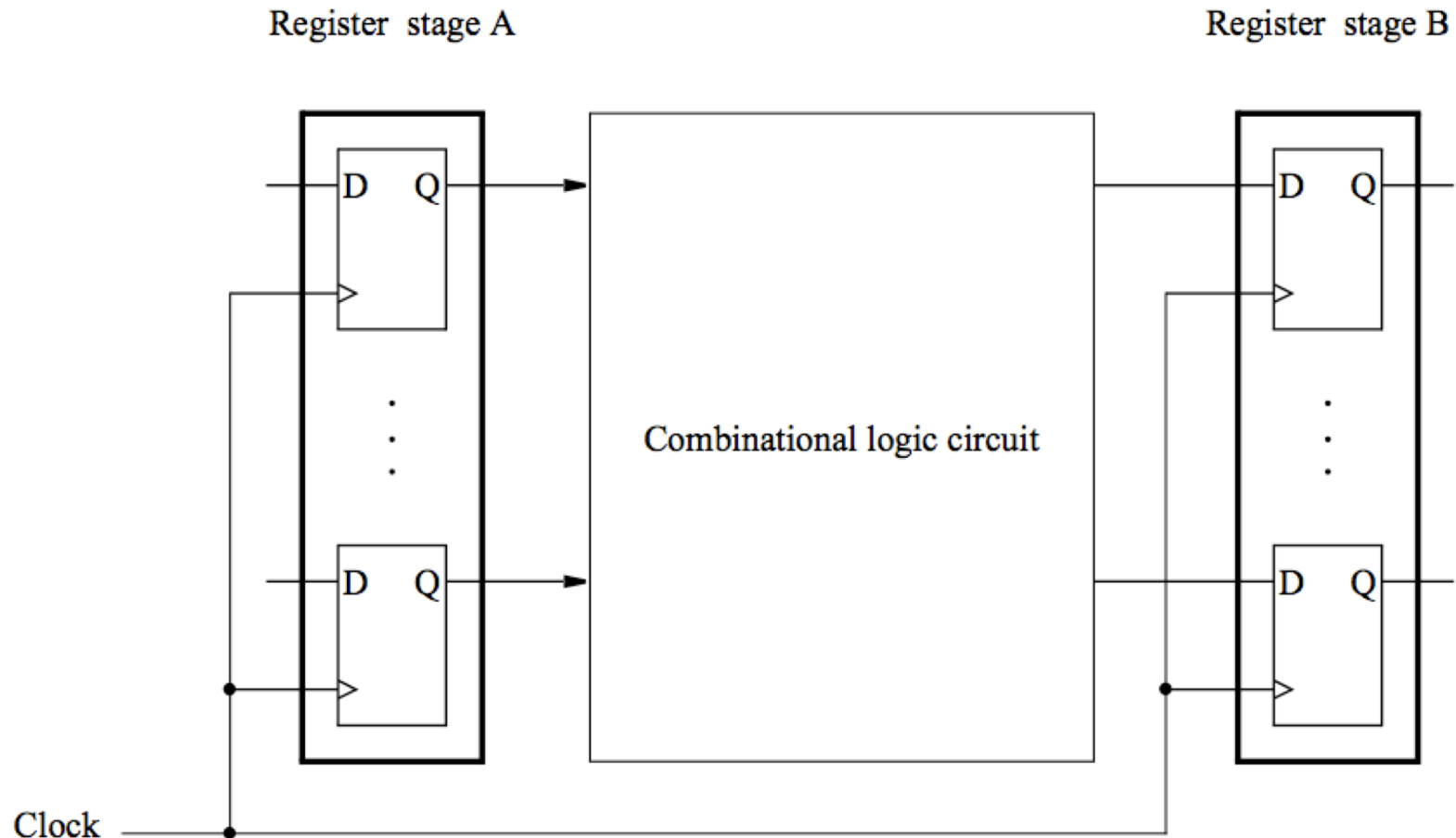

A multi-stage digital processing system

- datapath

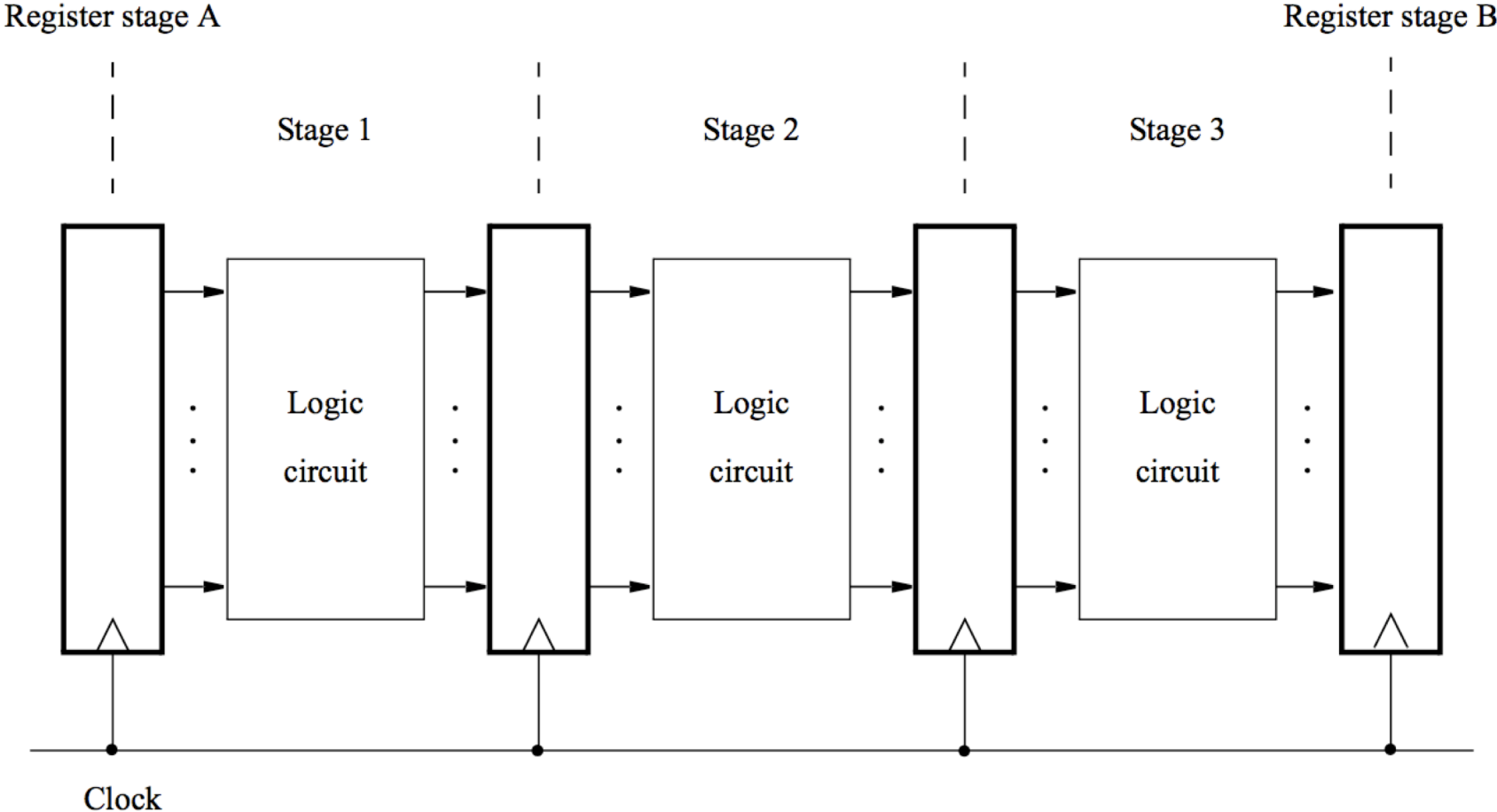

Why multi-stage?

- Processing moves from one stage to the next in each clock cycle
- Such a multi-stage system **is the basis** for **pipelined** operation
 - High-performance processors have a pipelined organization
 - Pipelining enables the execution of successive instructions to be overlapped
- We will get back to **pipeline** later. Let's now focus on the basics of the multi-stage architecture of a RISC-style processor

Instruction execution

- Pipelined organization is most effective if all instructions can be executed in the same number of steps.
- Each step is carried out in a separate hardware stage.
- Processor design will be illustrated using five hardware stages.
- **How can instruction execution be divided into five steps?**
 - Let's start from some representative RISC instructions

A memory access instruction:

Load R5, X(R7)

1. Fetch the instruction and increment the program counter.
2. Decode the instruction and read the contents of register R7 in the register file.
3. Compute the effective address = $X + [R7]$.
4. Read the memory source operand.
5. Load the operand into the destination register, R5.

A computational instruction:

Add R3, R4, R5

1. Fetch the instruction and increment the program counter.
 2. Decode the instruction and read registers R4 and R5.
 3. Compute the sum $[R4] + [R5]$.
 4. No action.
 5. Load the result into the destination register, R3.
- *Stage 4 (memory access) is not involved in this instruction.*

5-stage Architecture of a RISC Processor

1. Fetch an instruction and increment the program counter.
 2. Decode the instruction and read registers from the register file.
 3. Perform an ALU operation.
 4. Read or write memory data if the instruction involves a memory operand.
 5. Write the result into the destination register.
- This sequence determines the hardware stages needed.

Hardware components: Register file

- A 2-port register file is needed to read the two source registers at the same time.
- It may be implemented using a 2-port memory.

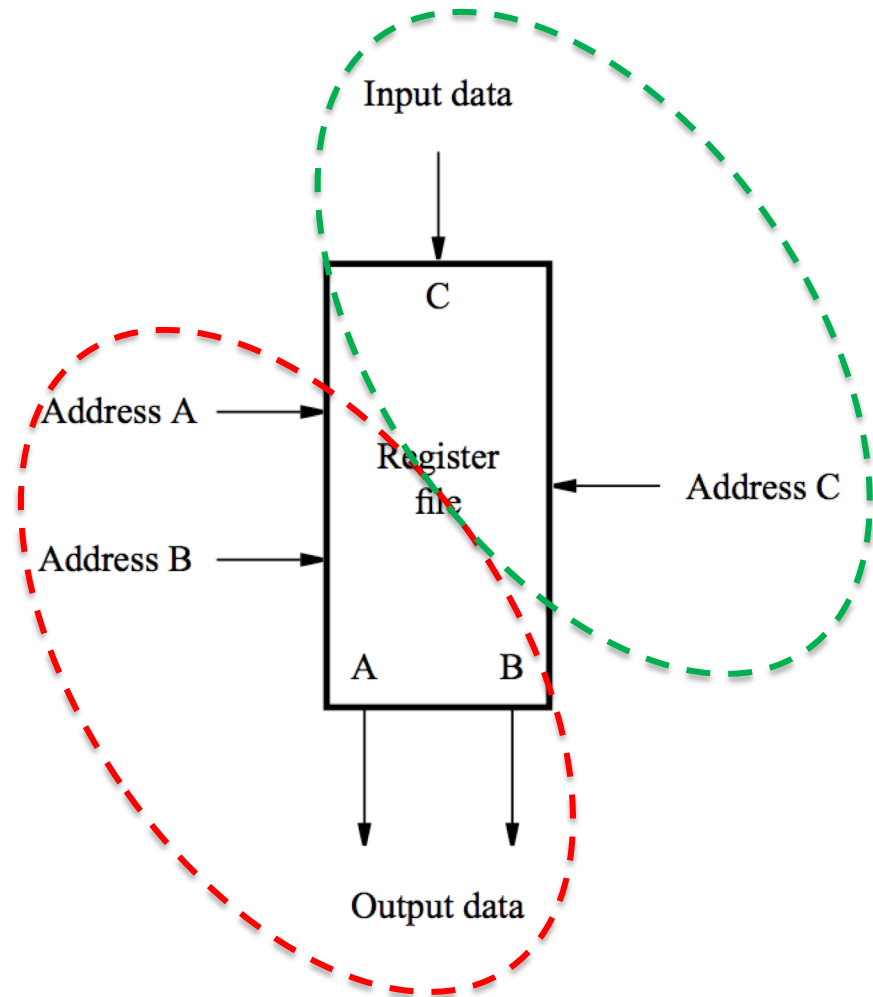

Hardware components: ALU (1)

- Both source operands and the destination location are in the register file.

[RA] and [RB] denote values of registers that are identified by addresses A and B

new [RC] denotes the result that is stored to the register identified by address C

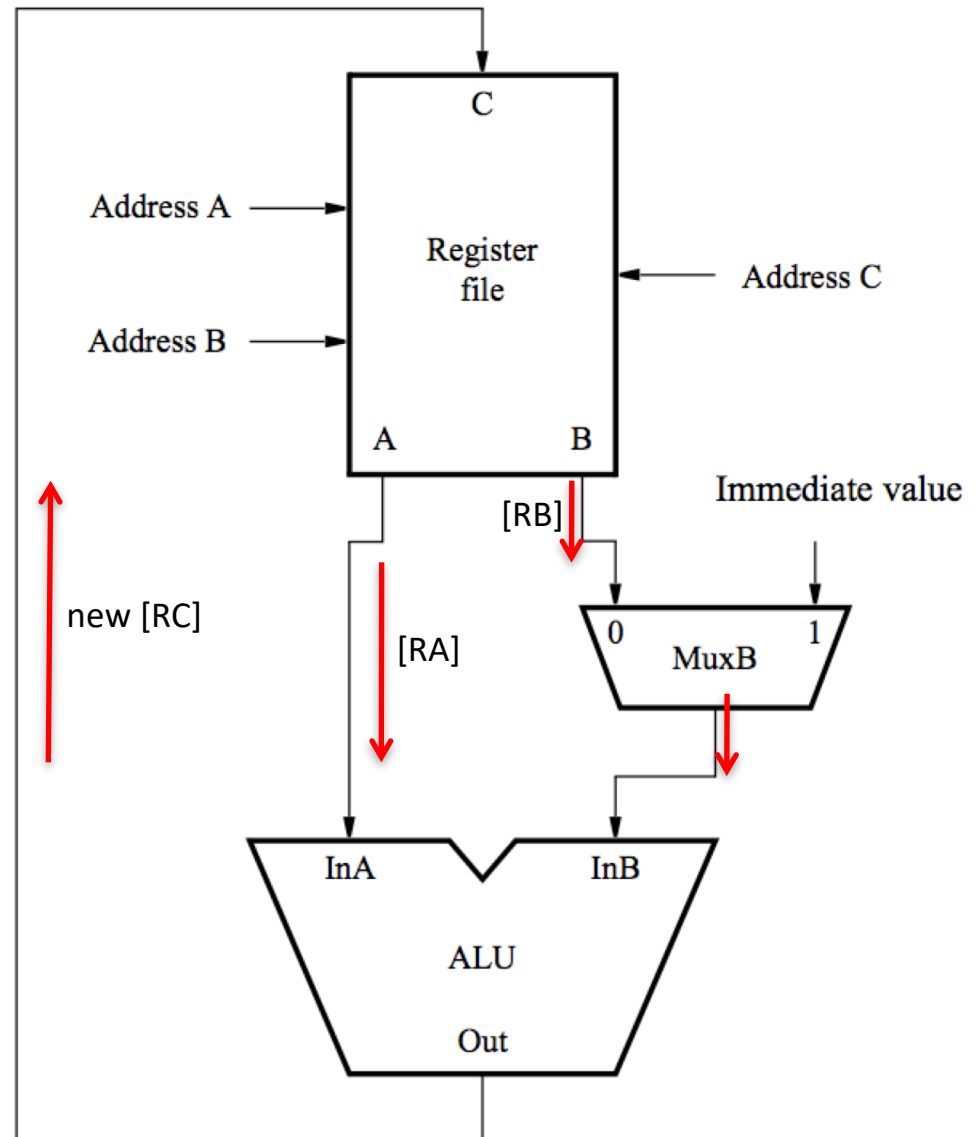

Hardware components: ALU (2)

- In this case, one of the source operands is the immediate value in the IR.

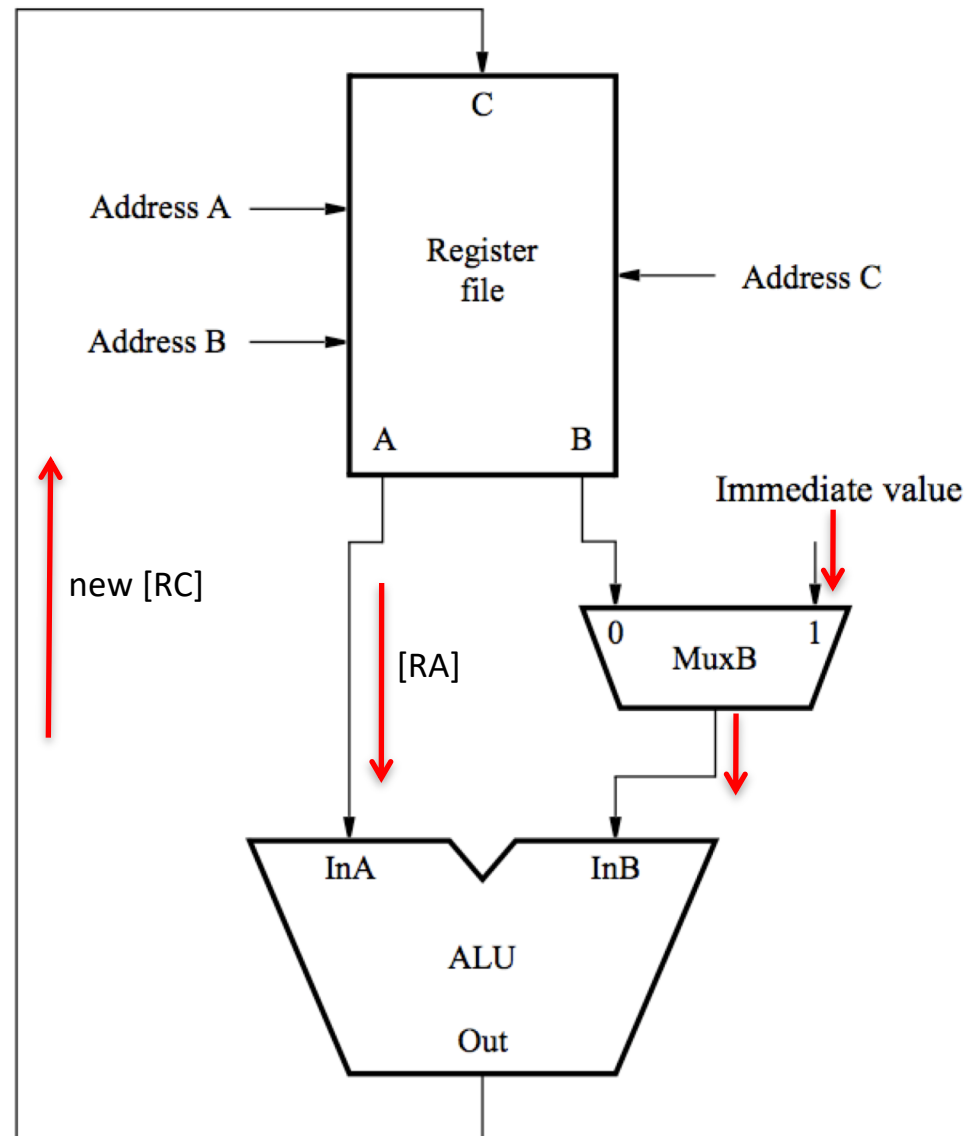

A 5-stage implementation of a RISC processor

- Instruction processing moves from stage to stage in every clock cycle, starting with **fetch**.
- The instruction is **decoded** and the source registers are read in stage 2.
- **Computation** takes place in the ALU in stage 3.

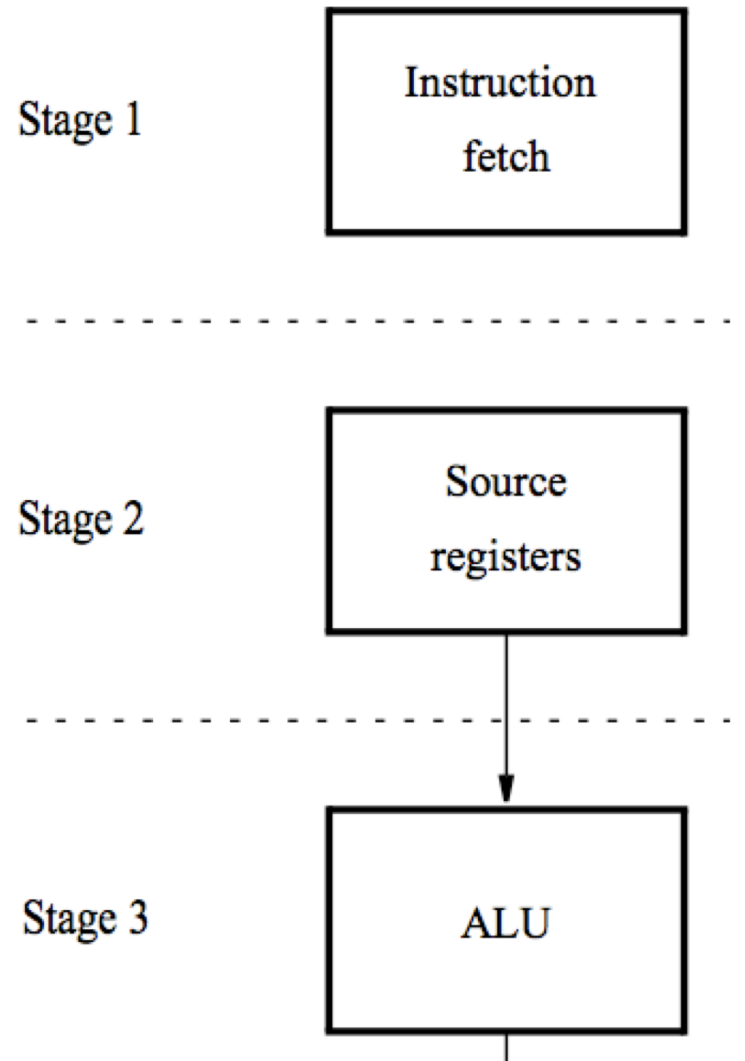

A 5-stage implementation of a RISC processor

- ...
- If a **memory** operation is involved, it takes place in stage 4.
- The result of the instruction is **written** in the destination register in stage 5.

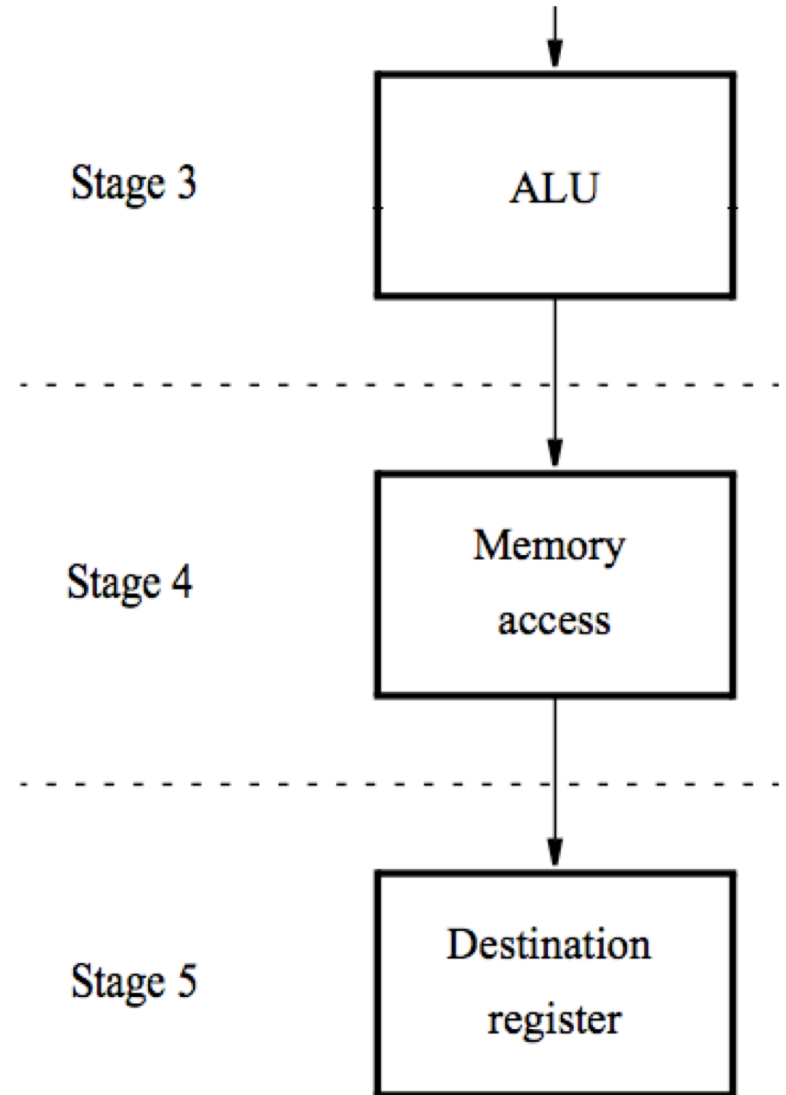

The datapath – Stages 2 to 5

- Register file, used in stages 2 and 5
 - (Inter-stage registers RA, RB, RZ, RM, RY needed to carry data from one stage to the next)
- ALU stage
- Memory stage
- Final stage to store result to the register file

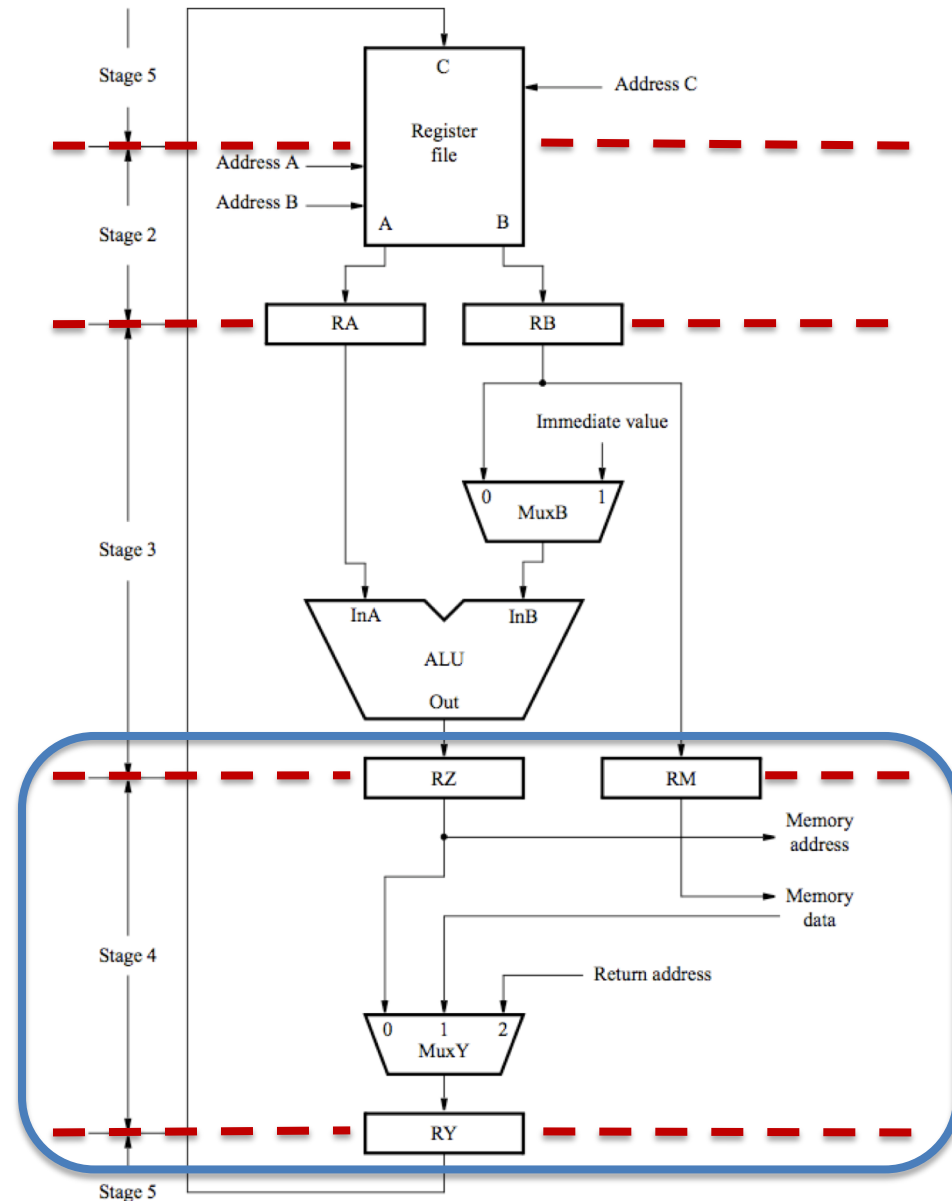

Memory stage

- **For a calculation instruction:**
 - MuxY selects [RZ] to be placed in RY.
- **For a memory instruction:**
 - RZ provides memory address, and MuxY selects read data to be placed in RY.
 - RM provides data for a memory write operation.
- **In subroutine calls or exception handling:**
 - Input 2 of MuxY is used (return address stored in the register file)

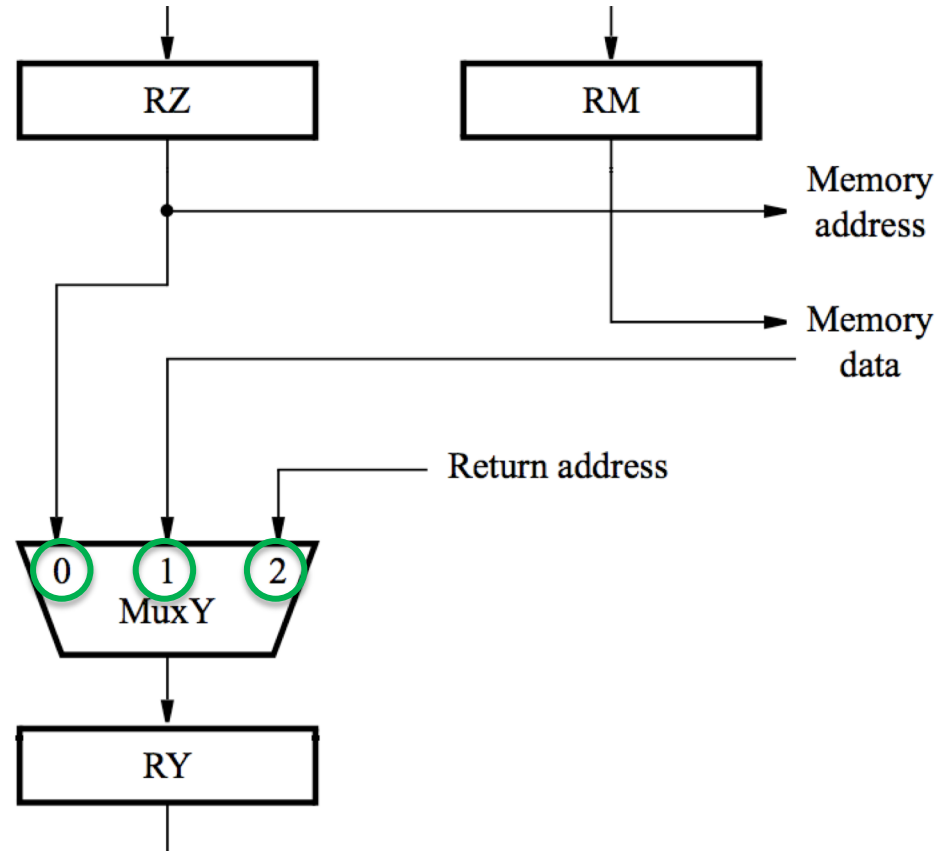

Instruction Fetch Stage (1)

- MuxMA selects the PC when fetching instructions (**RZ in the Memory Stage – we are assuming no Harvard architecture**)
- The **Instruction address generator** increments the PC after fetching an instruction
 - It also generates branch and subroutine addresses.

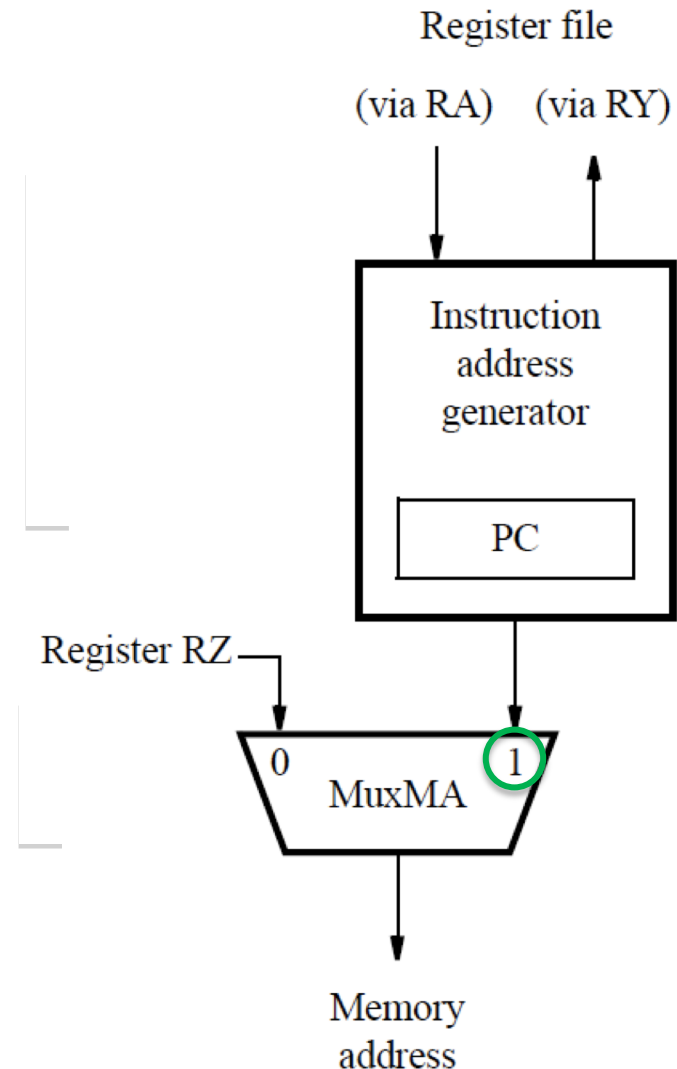

Instruction Fetch Stage (2)

- When an instruction is read, it is placed in IR.
- The control circuitry decodes the instruction.
 - It generates the control signals that drive all units.
- The Immediate block extends the immediate operand to 32 bits, according to the type of instruction.

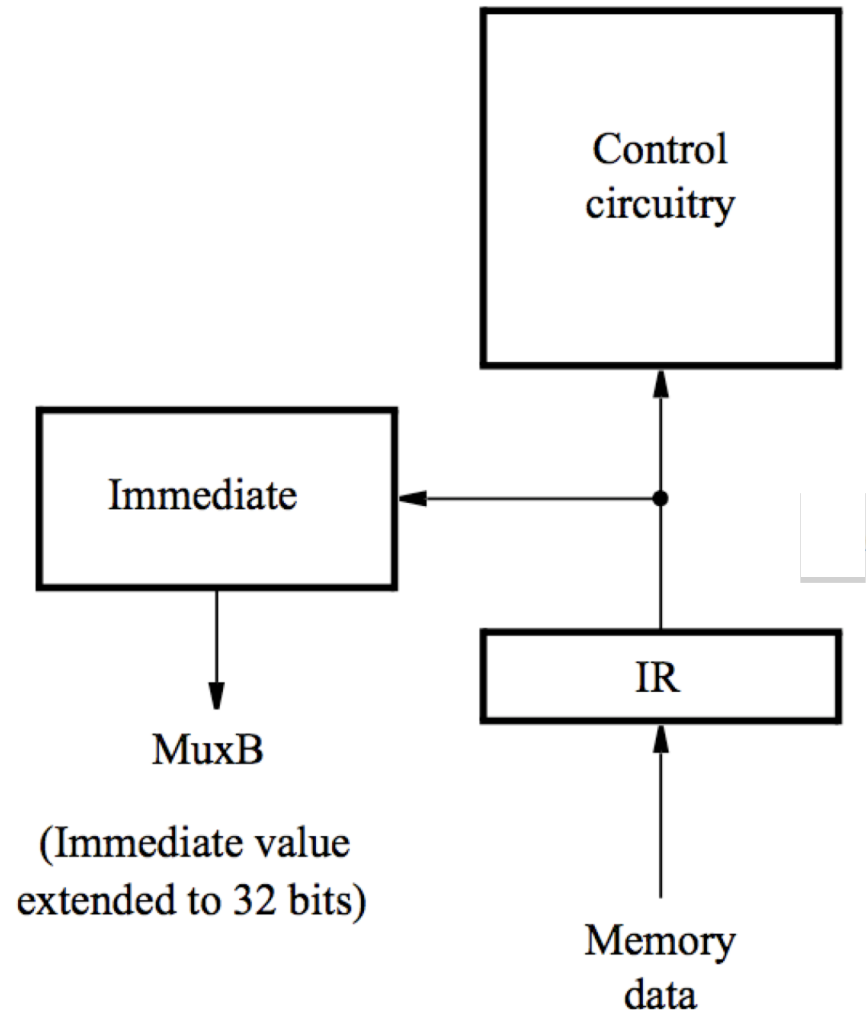

Instruction address generator

- Connections to registers RY and RA are used to support subroutine call and return instructions

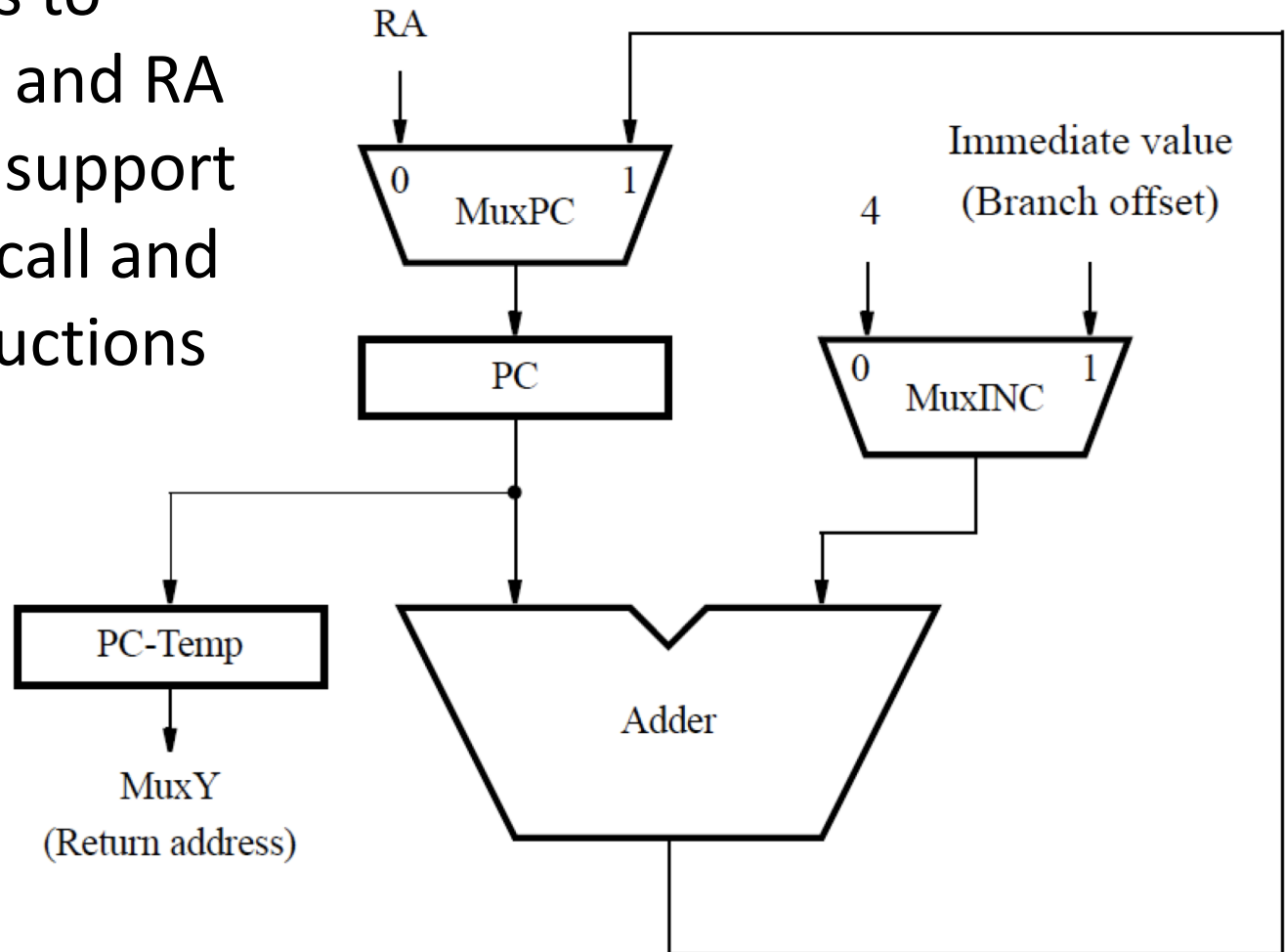

Example: Add R3, R4, R5

1. Memory address \leftarrow [PC],
Read memory,
 $IR \leftarrow$ Memory data,
 $PC \leftarrow [PC] + 4$
2. Decode instruction,
 $RA \leftarrow [R4]$, $RB \leftarrow [R5]$
3. $RZ \leftarrow [RA] + [RB]$
4. $RY \leftarrow [RZ]$
5. $R3 \leftarrow [RY]$

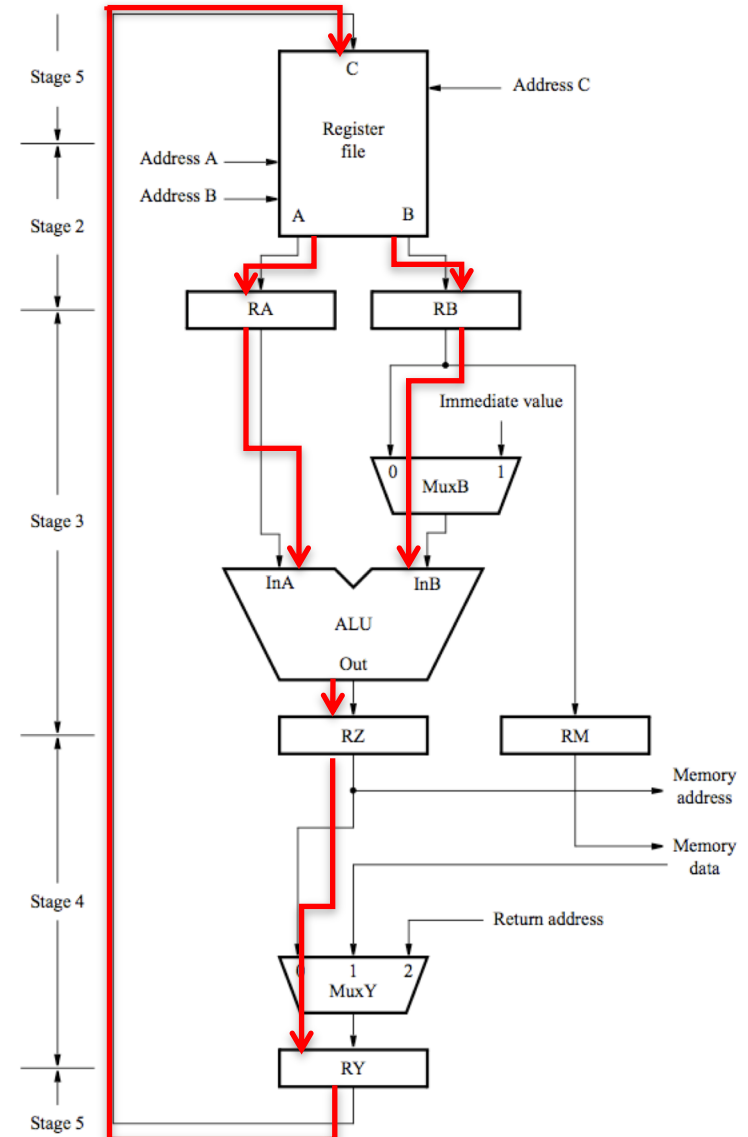

Example: Load R5, X(R7)

1. Memory address \leftarrow [PC],
Read memory,
IR \leftarrow Memory data,
PC \leftarrow [PC] + 4
2. Decode instruction,
RA \leftarrow [R7]
3. RZ \leftarrow [RA] + Immediate
value X
4. Memory address \leftarrow [RZ],
Read memory,
RY \leftarrow Memory data
5. R5 \leftarrow [RY]

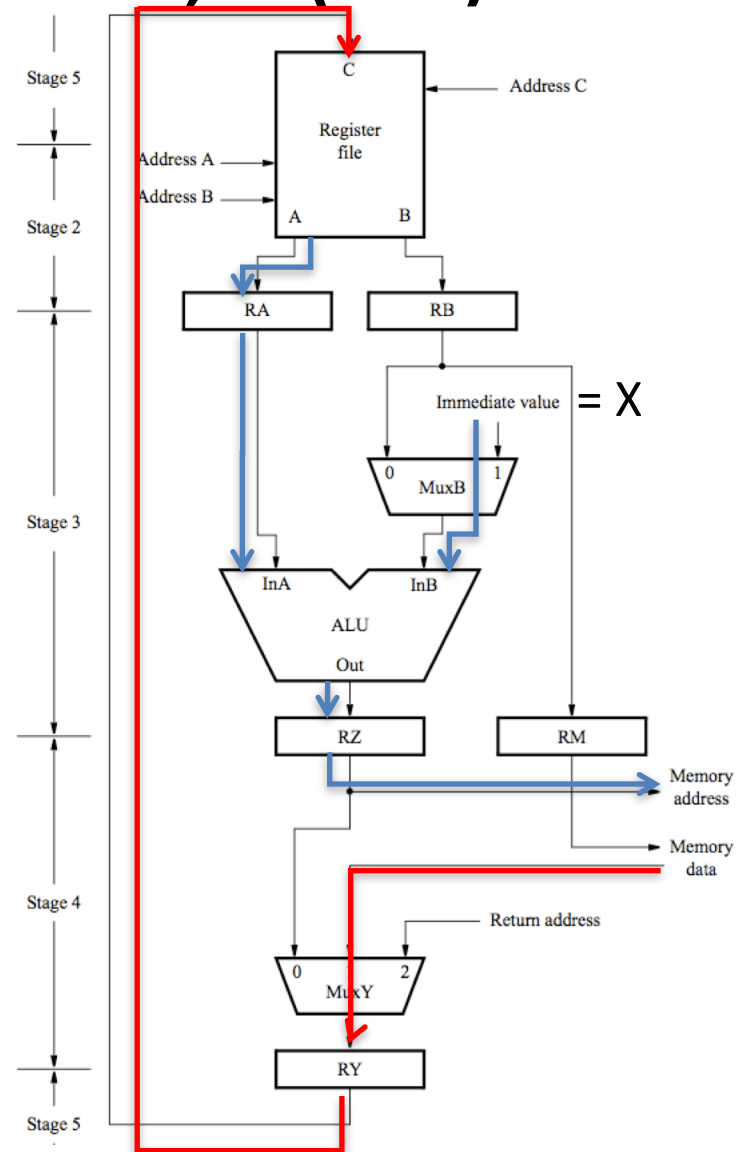

Example: Store R6, X(R8)

1. Memory address \leftarrow [PC],
Read memory,
IR \leftarrow Memory data,
PC \leftarrow [PC] + 4
2. Decode instruction,
RA \leftarrow [R8], RB \leftarrow [R6]
3. RZ \leftarrow [RA] + Immediate
value X, RM \leftarrow [RB]
4. Memory address \leftarrow [RZ],
Memory data \leftarrow [RM],
Write memory
5. No action

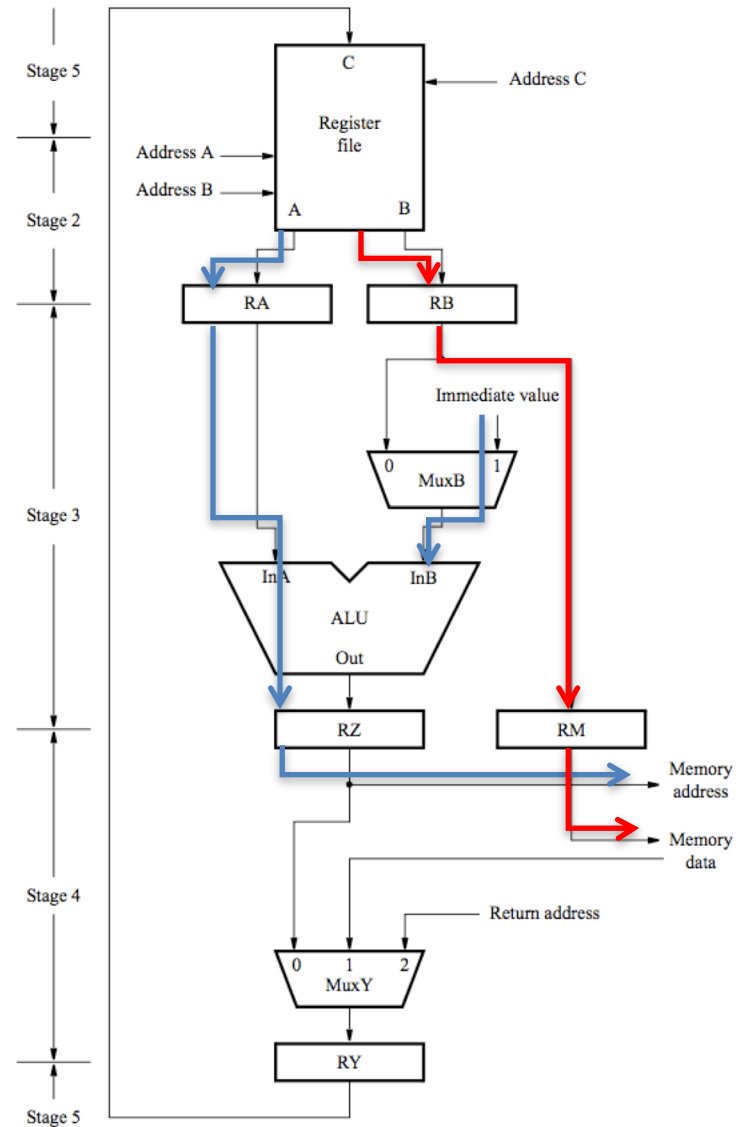

Unconditional branch

1. Memory address \leftarrow [PC], Read memory, IR \leftarrow Memory data, PC \leftarrow [PC] + 4
2. Decode instruction
3. PC \leftarrow [PC] + Branch offset
4. No action
5. No action

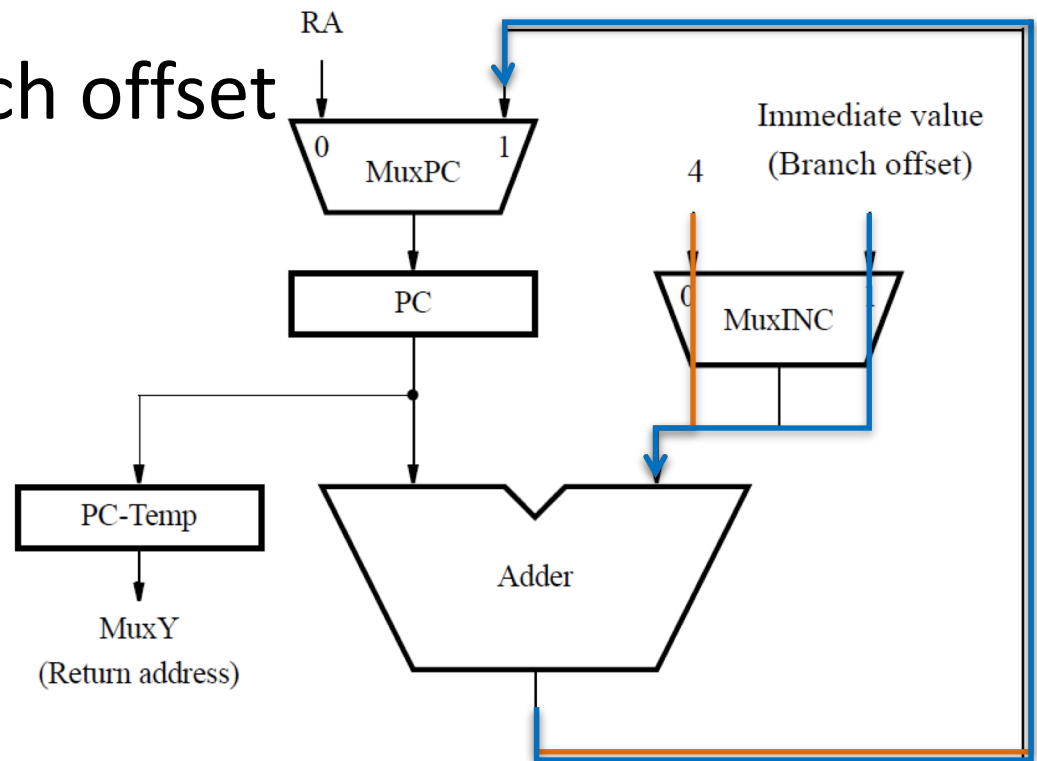

Conditional branch:

Branch_if_[R5]=[R6] LOOP

1. Memory address \leftarrow [PC], Read memory, IR \leftarrow Memory data, PC \leftarrow [PC] + 4
2. Decode instruction, RA \leftarrow [R5], RB \leftarrow [R6]
3. Compare [RA] to [RB],
If [RA] = [RB], then
PC \leftarrow [PC] + Branch offset
4. No action
5. No action

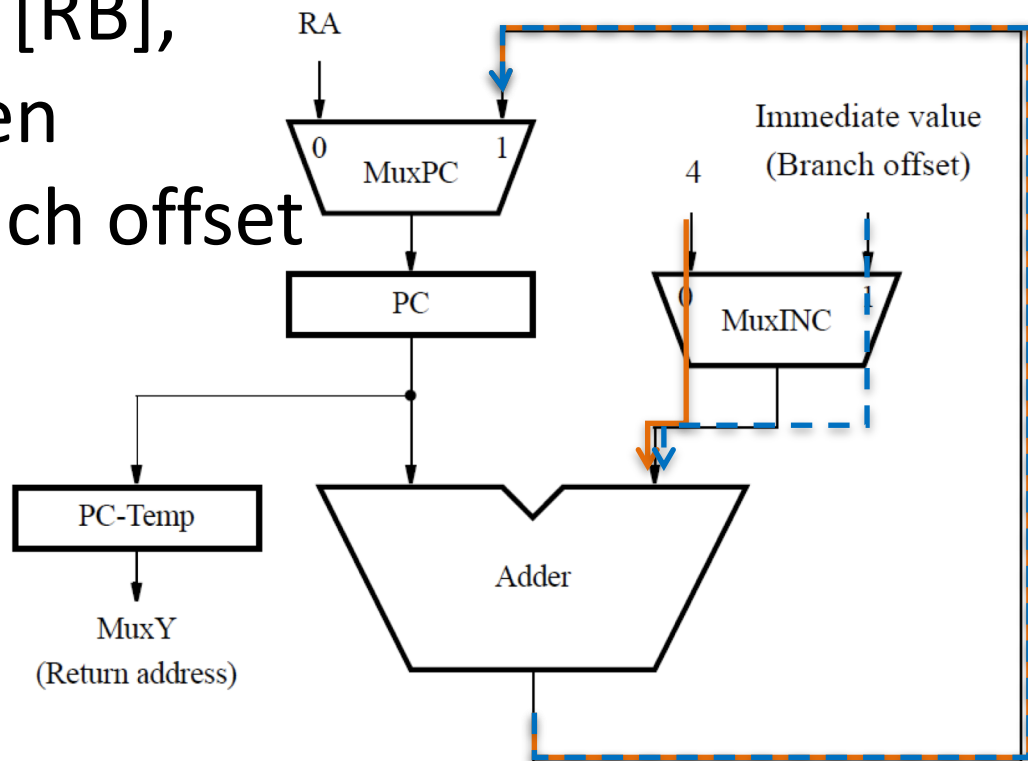

Subroutine call with indirection: Call_register R9

1. Memory address \leftarrow [PC], Read memory,
IR \leftarrow Memory data, PC \leftarrow [PC] + 4
2. Decode instruction, RA \leftarrow [R9]
3. PC-Temp \leftarrow [PC],
PC \leftarrow [RA]
4. RY \leftarrow [PC-Temp]
5. Register LINK \leftarrow [RY]

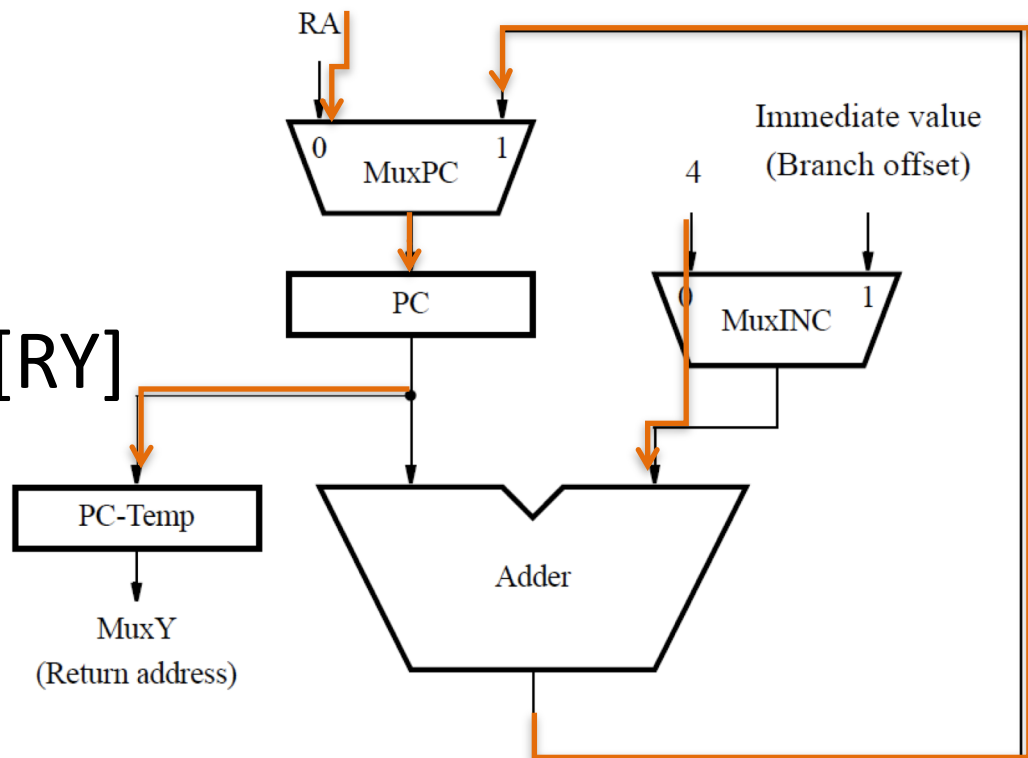

Control signals

- Select multiplexer inputs to route the flow of data
- Set the function performed by the ALU
- Determine when data are written into the PC, the IR, the register file, and the memory

Register file control signals

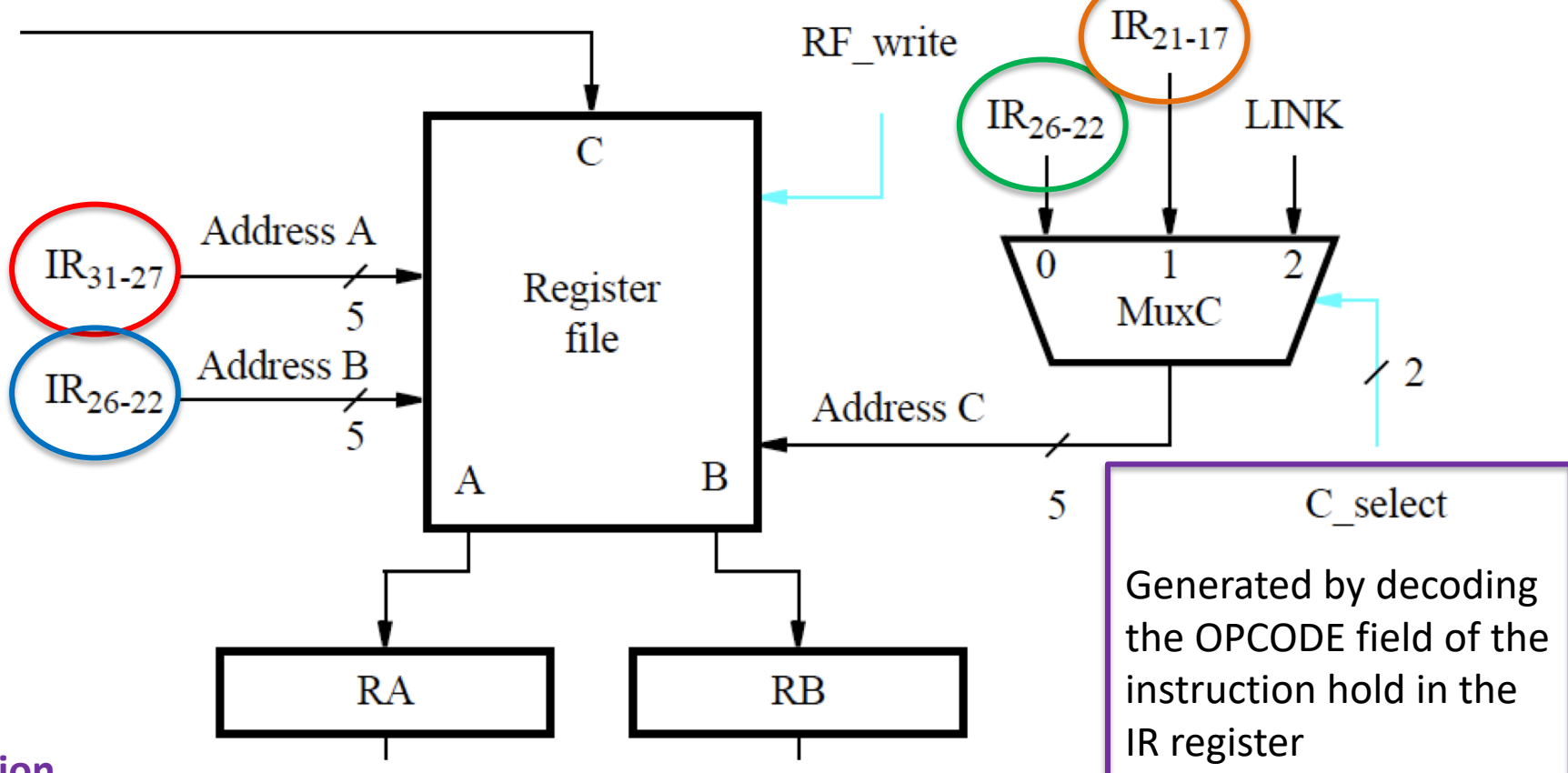

C_select
Generated by decoding the OP code field of the instruction hold in the IR register

Instruction Format

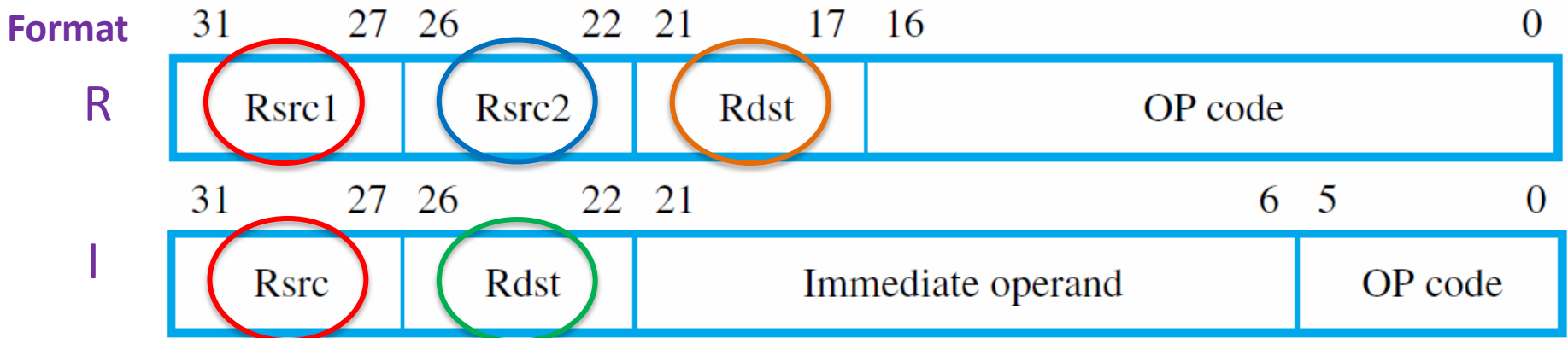

ALU control signals

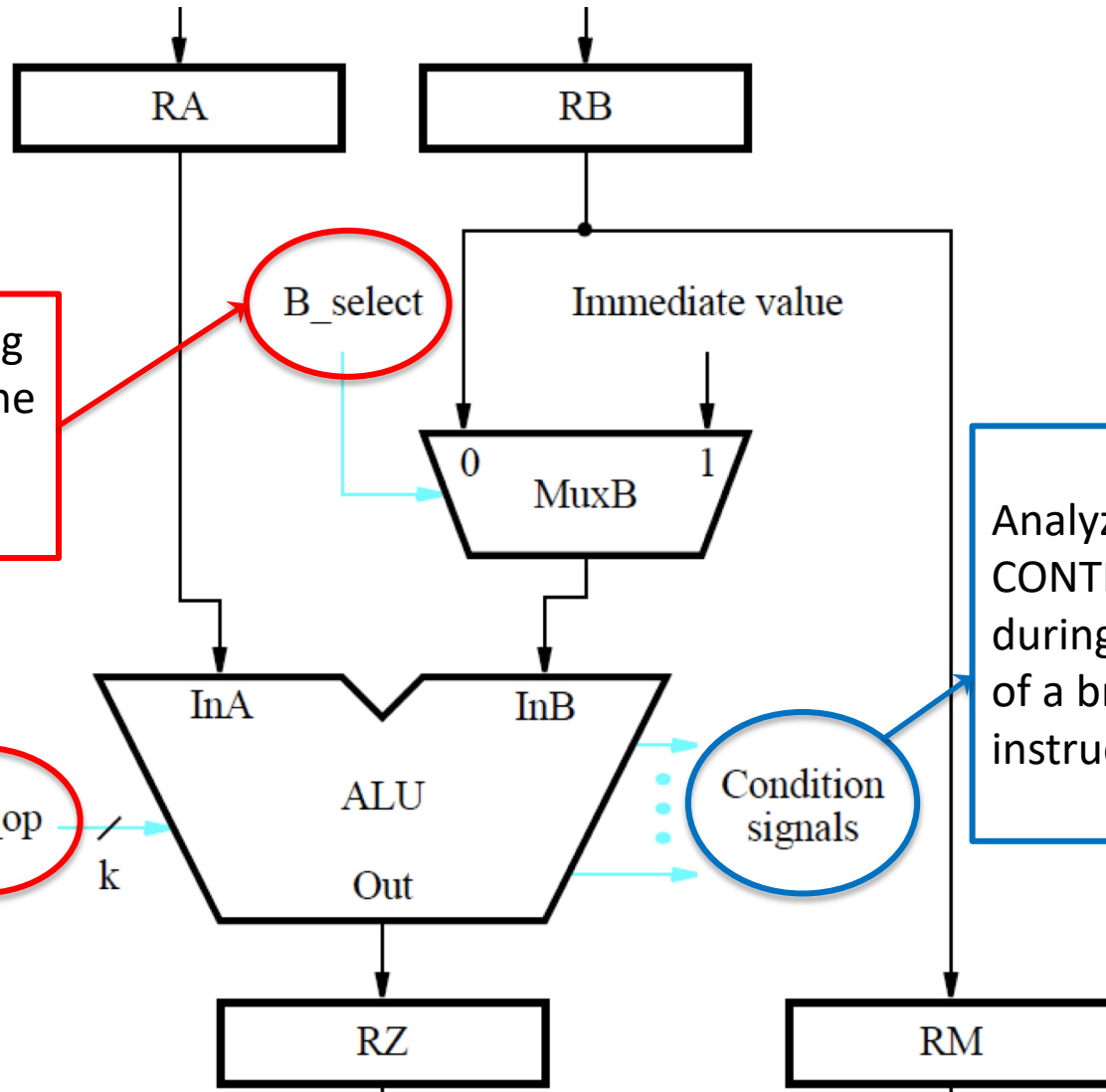

Generated by decoding the OPCODE field of the instruction hold in the IR register

Analyzed by the CONTROL CIRCUITRY during the execution of a branch instruction

Result selection

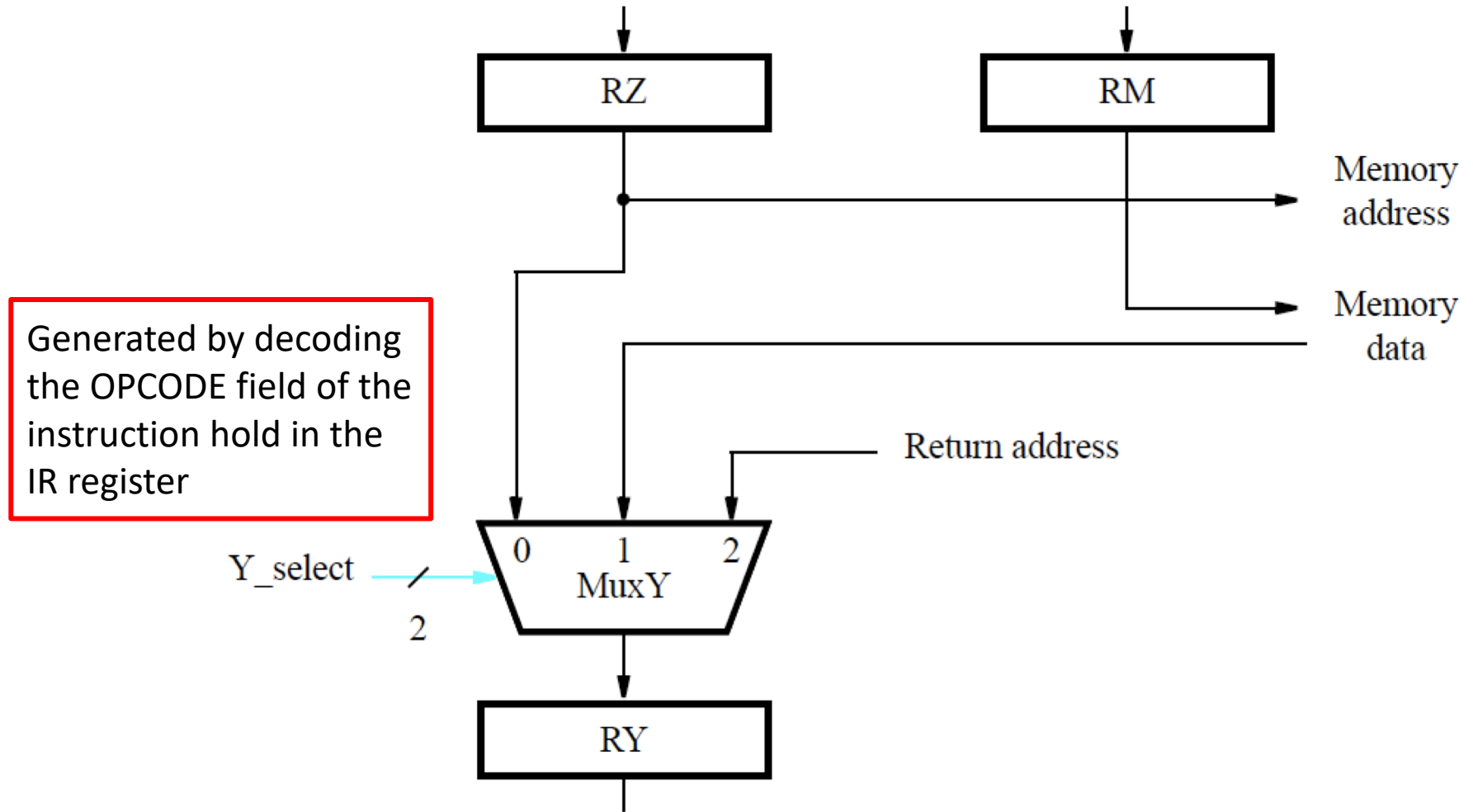

Memory access

- When data are found in the cache, access to memory can be completed in one clock cycle.
- Otherwise, read and write operations may require several clock cycles to load data from main memory into the cache.
- A control signal is needed to indicate that memory function has been completed (**MFC**).
E.g., for step 1:
 1. Memory address \leftarrow [PC], Read memory,
Wait for MFC,
IR \leftarrow Memory data, PC \leftarrow [PC] + 4

Memory and IR control signals

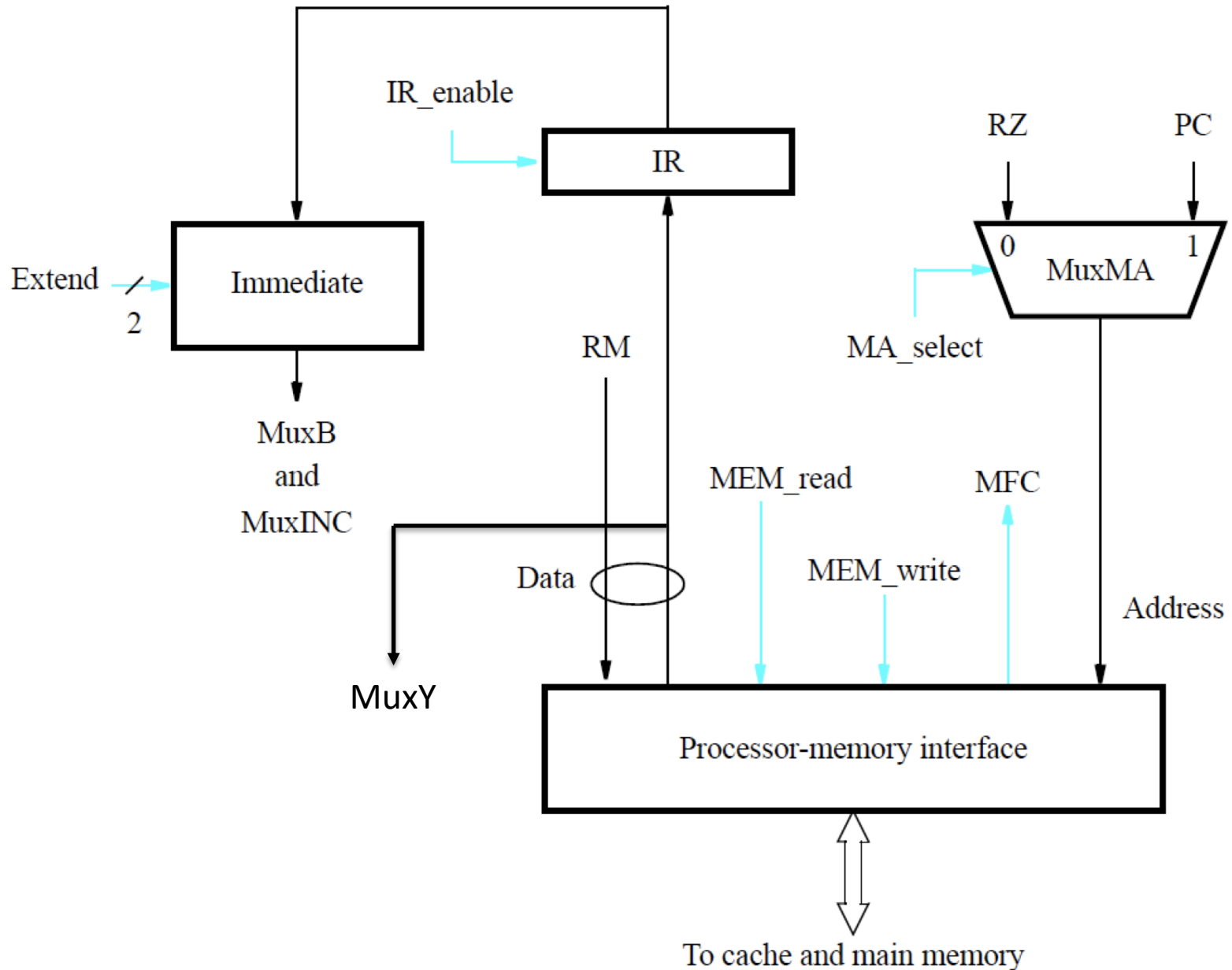

Memory and IR control signals

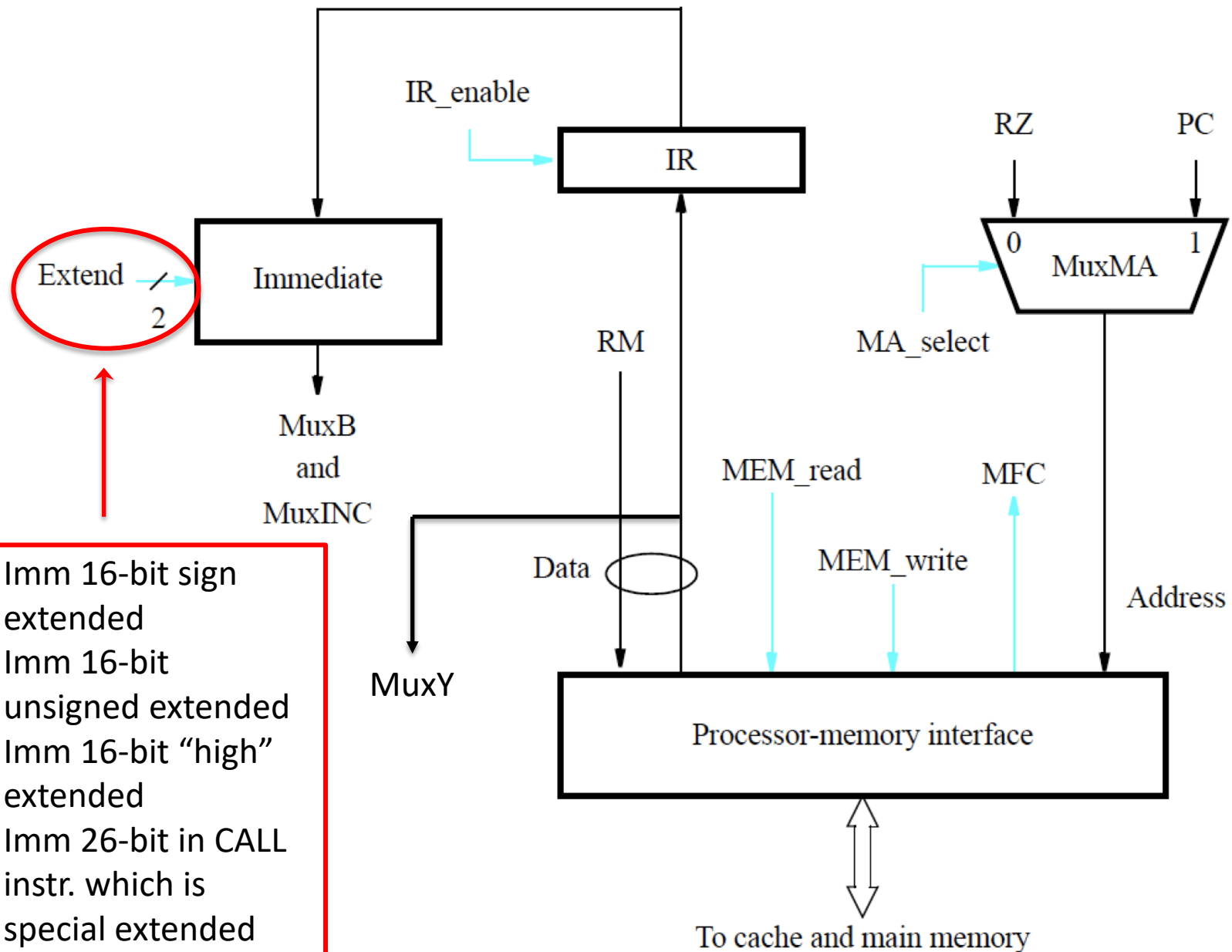

Control signals of instruction address generator

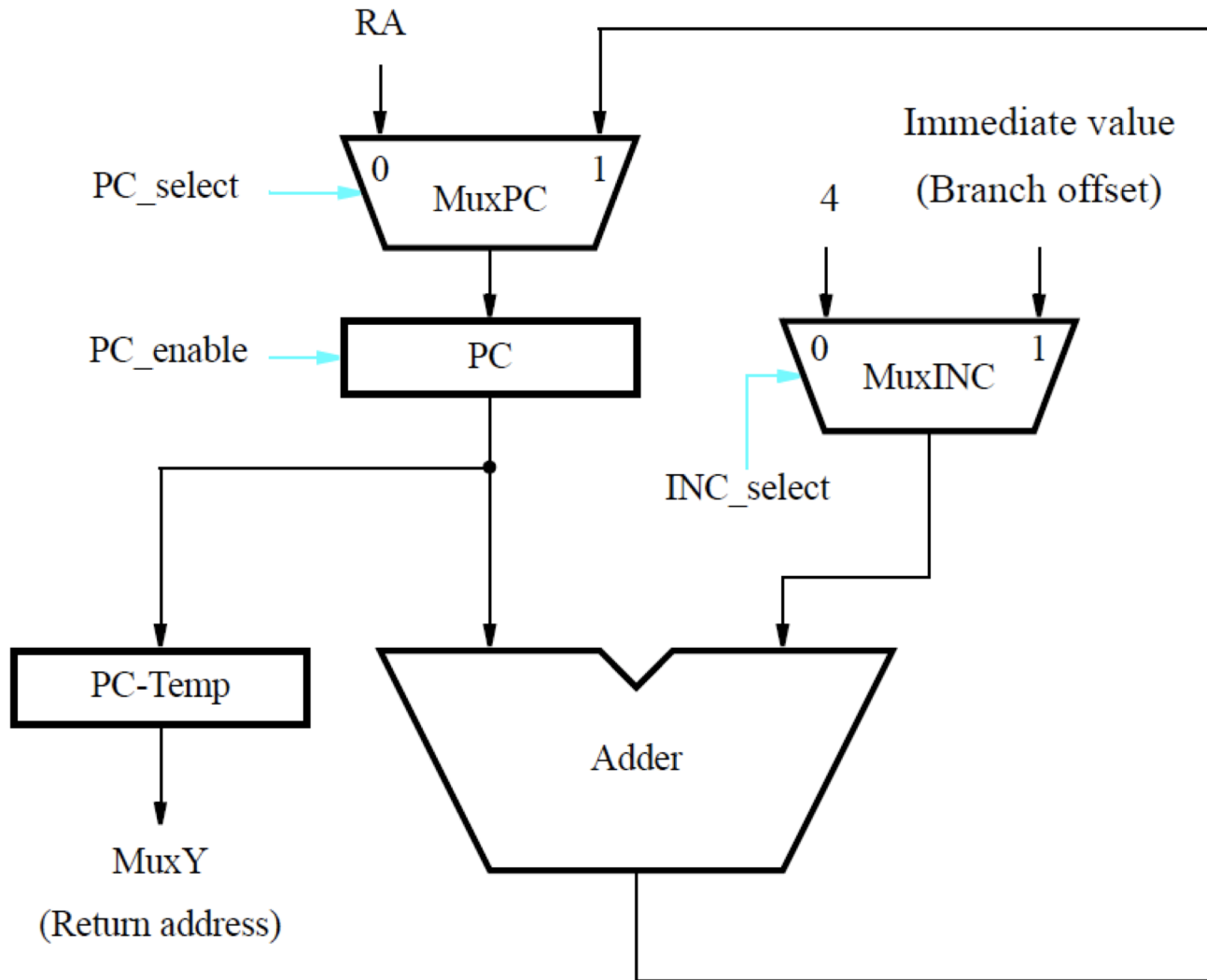

Control signal generation

- Circuitry must be implemented to generate control signals so actions take place in correct sequence and at correct time.
- There are two basic approaches:
 - hardwired control and microprogramming
- **Hardwired control** involves implementing circuitry that considers step (ring) counter, IR, ALU result, and external inputs.
- Step (Ring) counter keeps track of execution progress, one clock cycle for each of the five steps described (unless a memory access takes longer than one cycle).

Hardwired generation of control signals

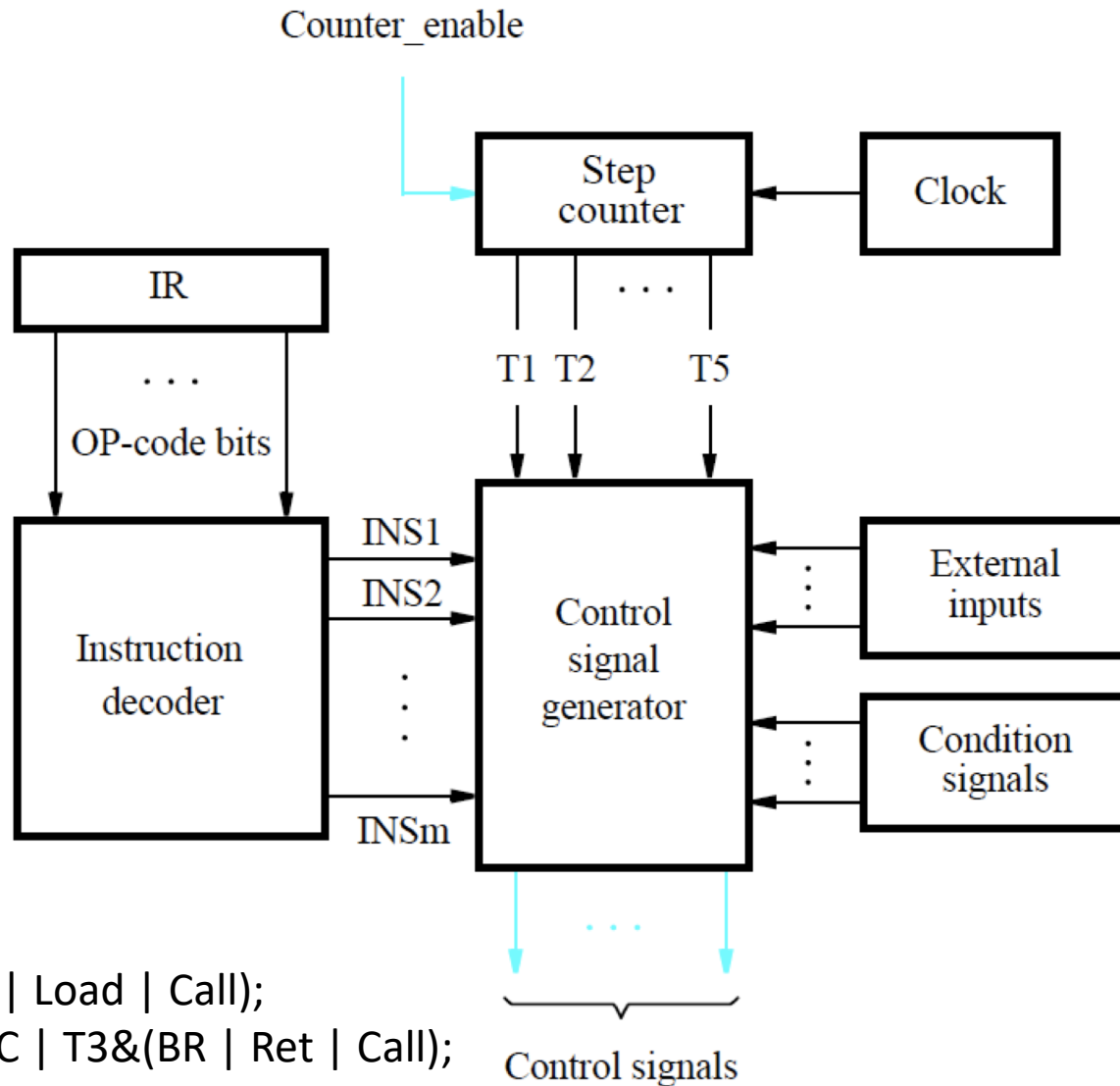

E.g.

$RF_write = T5 \& (ALU \mid Load \mid Call);$

$PC_enable = T1 \& MFC \mid T3 \& (BR \mid Ret \mid Call);$

CISC processors

- CISC-style processors have more complex instructions.
- The full set of instructions cannot all be implemented in a fixed number of steps.
- Execution steps for different instructions do not all follow a prescribed sequence of actions.
- Hardware organization should therefore enable a flexible flow of data and actions to accommodate CISC.

Hardware organization for a CISC computer

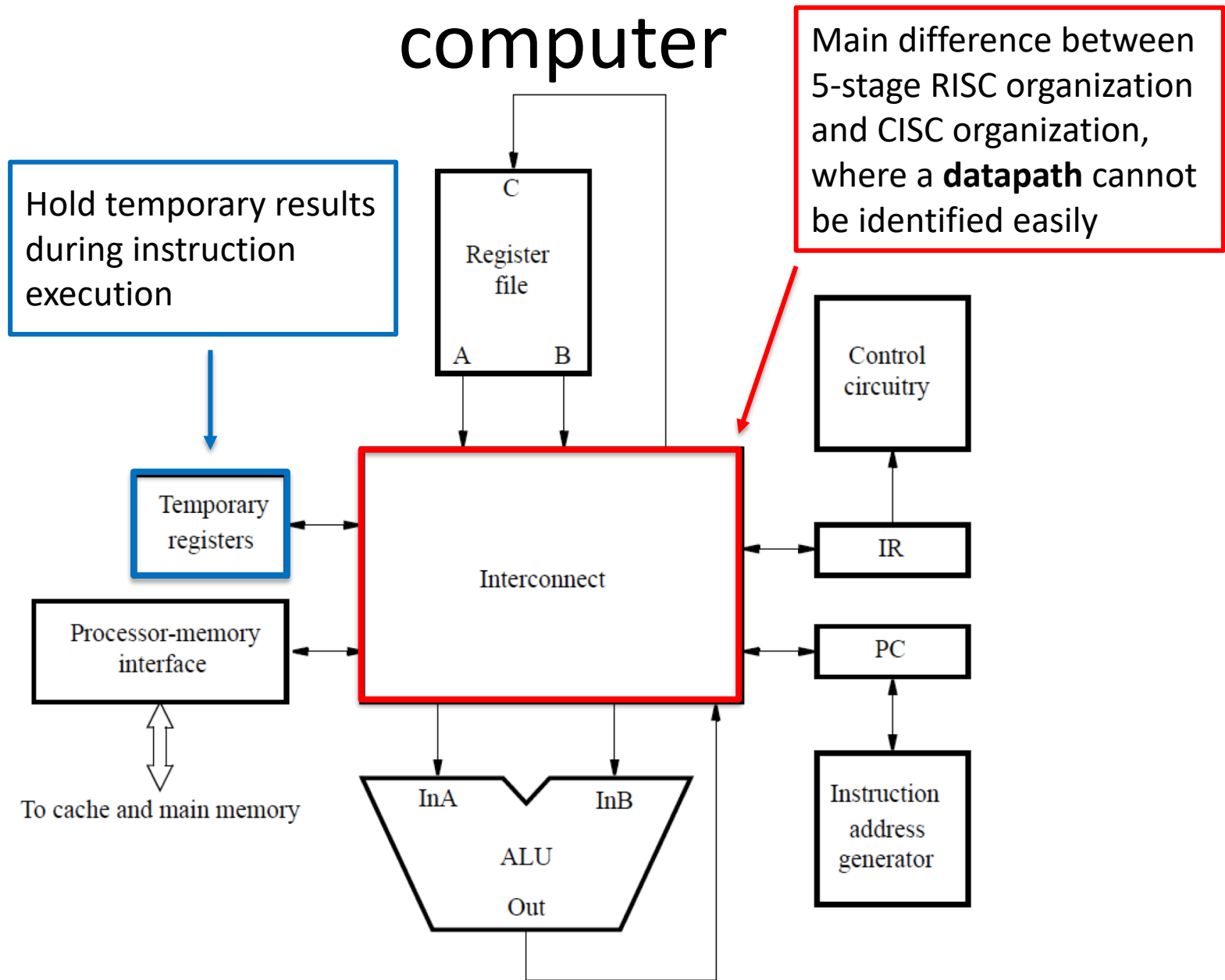

Bus

- An example of an interconnection network.
- When functional units are connected to a common bus, tri-state drivers are needed.

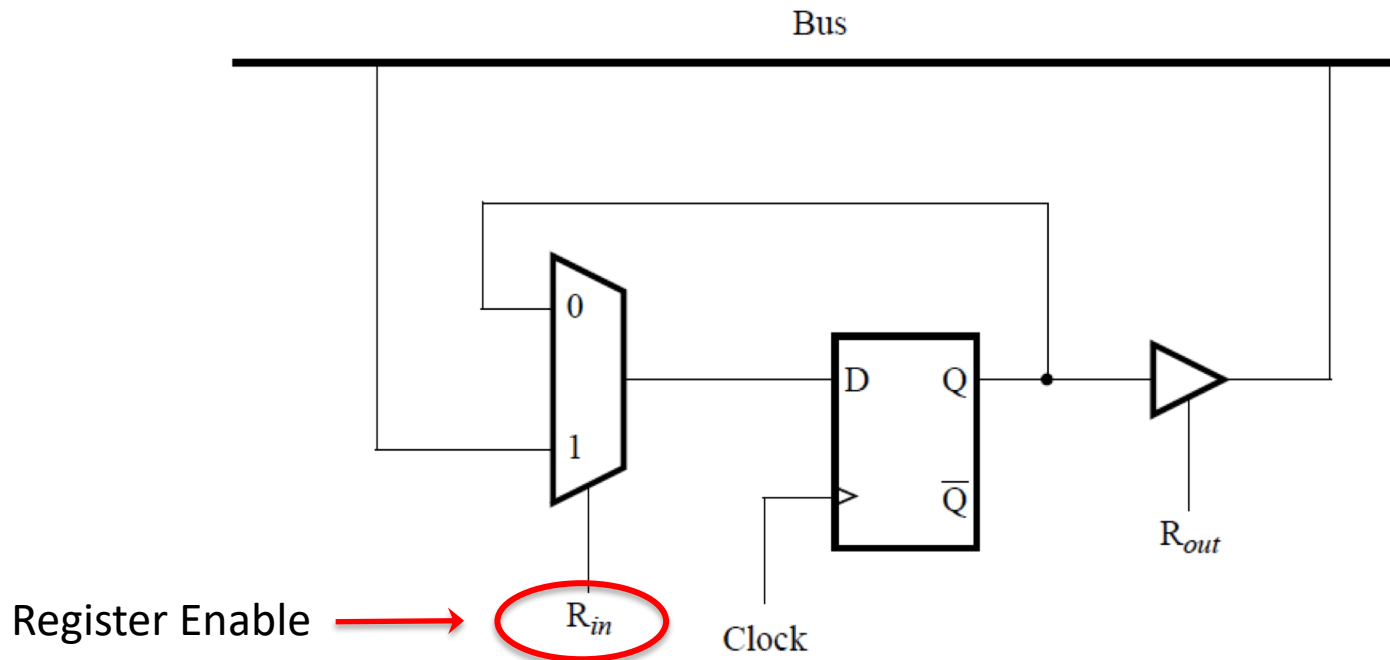

A 3-bus interconnection network

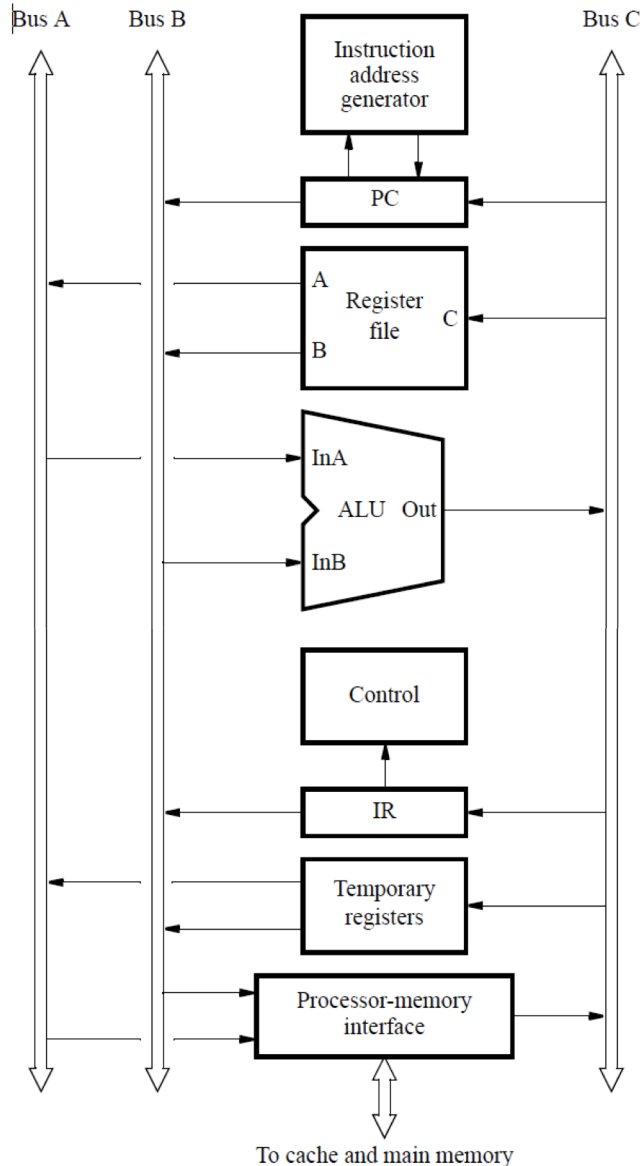

Example 1: Add R5, R6

1. Memory address \leftarrow [PC], Read memory, Wait for MFC, IR \leftarrow Memory data, PC \leftarrow [PC] + 4
2. Decode instruction
3. R5 \leftarrow [R5] + [R6]

A 3-bus interconnection network

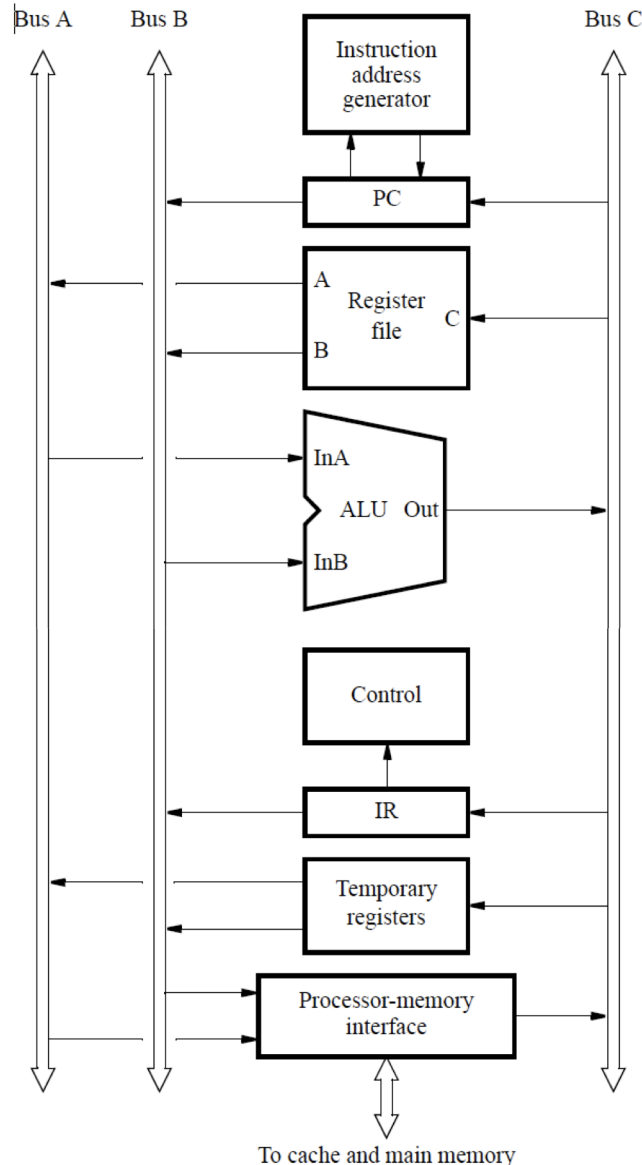

Example 2: And X(R7), R9

1. Memory address $\leftarrow [PC]$, Read memory, Wait for MFC, IR \leftarrow Memory data, PC $\leftarrow [PC] + 4$
2. Decode instruction
3. Memory address $\leftarrow [PC]$, Read memory, Wait for MFC, **Temp1** \leftarrow Memory data, PC $\leftarrow [PC] + 4$
4. **Temp2** $\leftarrow [Temp1] + [R7]$
5. Memory address $\leftarrow [Temp2]$, Read memory, Wait for MFC, **Temp1** \leftarrow Memory data
6. **Temp1** $\leftarrow [Temp1] \text{ AND } [R9]$
7. Memory address $\leftarrow [Temp2]$, Memory data $\leftarrow [Temp1]$, Write memory, Wait for MFC

X is stored as a second word of the instruction

References

- C. Hamacher, Z. Vranesic, S. Zaky, N. Manjikian
"Computer Organization and Embedded Systems,"
McGraw-Hill International Edition
– Chapter V: Basic Processing Unit